

ALGEBRA

VA MATEMATIK ANALIZ

ASOSLARI

I



O‘ZBEKISTON RESPUBLIKASI
OLIY VA O‘RTA MAXSUS TA‘LIM VAZIRLIGI
O‘RTA MAXSUS, KASB-HUNAR TA‘LIMI MARKAZI

A. U. Abduhamidov, H. A. Nasimov,
U. M. Nosirov, J. H. Husanov

ALGEBRA VA
MATEMATIK ANALIZ
ASOSLARI

I qism

Akademik litseylar uchun darslik

7- nashri

Ushbu darslik 2002- yilda o'tkazilgan „Yilning eng yaxshi darsligi va o'quv adabiyoti“ respublika tanlovida birinchi o'rinni egallagan.

Taqrizchilar: K. Behzod nomidagi Milliy rassomlik va dizayn institutining tayinlangan professori, texnika fanlari nomzodi, dotsent **R. Yarqulov**, SamDU qoshidagi gimnaziyaning oliy toifali matematika o'qituvchisi, fizika-matematika fanlari nomzodi, dotsent **H. N. Nosirova**, O'MKHT markazi kollejlarda boshqarmasining bosh mutaxassisi, fizika-matematika fanlari nomzodi **J. Shasalimov**.

O'zbekiston Respublikasi Oliy va o'rta maxsus ta'lim vazirligi, O'rta maxsus, kasb-hunar ta'limi markazi hamda O'rta maxsus, kasb-hunar ta'limini rivojlantirish instituti tomonidan akademik litseylar uchun darslik sifatida tavsiya etilgan bo'lib, undan kasb-hunar kollejlari talabalari va o'qituvchilari ham foydalanishlari mumkin.

O'zbekiston Respublikasida xizmat ko'rsatgan Xalq ta'limi xodimi **H. A. NASIMOV** ning umumiy tahriri ostida.



SO'ZBOSHI

„Algebra va matematik analiz asoslari“ darsligi ikki qismdan iborat bo'lib, akademik litseylar va kasb-hunar kollejlari uchun mo'ljallangan hamda shu fan bo'yicha akademik litseylar va kasb-hunar kollejlari o'quv rejasiga asosan, aniq fanlar yo'nalishi, tabiiy fanlar yo'nalishi, shuningdek, matematika umumta'lim fani sifatida o'rganiladigan guruhlarning „Algebra va matematik analiz asoslari“ kursining o'quv dasturidagi barcha materiallarni o'z ichiga oladi. Mualliflarning SamDU akademik litseyida to'plagan ish tajribalari asosida yaratilgan ushbu darslikning I qismi sakkiz bobdan iborat bo'lib, unda quyidagi mavzular yoritilgan:

- to'plamlar nazariyasi va matematik mantiq elementlari;
- haqiqiy sonlar;
- kompleks sonlar va ular ustida amallar;
- ko'phadlar;
- algebraik ifodalar;
- algebraik tenglamalar va tengsizliklar;
- funksiyalar;
- ko'rsatkichli va logarifmik funksiyalar.

Har bir bob paragraflarga, paragraflar esa bandlarga bo'lingan.

Materiallar bayonida mualliflar nazarida zarur deb hisoblangan o'rinlarda to'plamlar nazariyasi va matematik mantiq elementlari tilidan foydalanilgan.

Darslikning yaratilish jarayonida o'zlarining qimmatli maslahatlarini ayamagan SamDU akademik litseyining matematika o'qituvchilari R. Narzullayeva va F. Xo'jayevaga, Samarqand viloyati Ishtixon tumani 21- o'rta maktabning oliy toifali matematika o'qituvchisi, O'zbekiston Respublikasida xizmat ko'rsatgan Xalq ta'limi xodimi A. A. Nasimovga hamda uni nashrga tayyorlashda katta yordam bergan I.H. Nasimovga o'z minnatdorchiligimizni bildiramiz.

1- §. To'plamlar nazariyasining
asosiy tushunchalari

1. To'plam haqida tushuncha. To'plam tushunchasi matematikaning boshlang'ich (ta'riflanmaydigan) tushunchalaridan biridir. U chekli yoki cheksiz ko'p obyektlar (narsalar, buyumlar, shaxslar va h.k.) ni birgalikda bir butun deb qarash natijasida vujudga keladi.

Masalan, O'zbekistondagi viloyatlar to'plami; viloyatdagi akademik litseylar to'plami; butun sonlar to'plami; to'g'ri chiziq kesmasidagi nuqtalar to'plami; sinfdagi o'quvchilar to'plami va hokazo. To'plamni tashkil etgan obyektlar uning *elementlari* deyiladi.

To'plamlar odatda lotin alifbosining bosh harflari bilan, uning elementlari esa shu alifboning kichik harflari bilan belgilanadi. Masalan, $A = \{a, b, c, d\}$ yozuvi A to'plam a, b, c, d elementlardan tashkil topganligini bildiradi.

x element X to'plamga *tegishli* ekanligi $x \in X$ ko'rinishda, *tegishli emasligi* esa $x \notin X$ ko'rinishda belgilanadi.

Masalan, barcha natural sonlar to'plami N va $4, 5, \frac{3}{4}, \pi$ sonlari uchun $4 \in N, 5 \in N, \frac{3}{4} \notin N, \pi \notin N$ munosabatlar o'rinli.

Biz, asosan, yuqorida ko'rsatilganidek buyumlar, narsalar to'plamlari bilan emas, balki sonli to'plamlar bilan shug'ullanamiz. Sonli to'plam deyilganda, barcha elementlari sonlardan iborat bo'lgan har qanday to'plam tushuniladi. Bunga N – natural sonlar to'plami, Z – butun sonlar to'plami, Q – ratsional sonlar to'plami, R – haqiqiy sonlar to'plami misol bo'la oladi.

To'plam o'z elementlarining to'liq ro'yxatini ko'rsatish yoki shu to'plamga tegishli bo'lgan elementlarga qanoatlantiradigan shartlar sistemasini berish bilan to'liq aniqlanishi mumkin. To'plamga tegishli bo'lgan elementlarga qanoatlantiradigan shartlar sistemasi shu to'plamning *xarakteristik xossasi* deb ataladi.

Barcha x elementlari biror b xossaga ega bo'lgan to'plam $X = \{x | b(x)\}$ kabi yoziladi. Masalan, ratsional sonlar to'plamini $Q = \{r | r = \frac{p}{q}, p \in Z, q \in N\}$ ko'rinishda, $ax^2 + bx + c = 0$ kvadrat tenglama ildizlari to'plamini esa $X = \{x | ax^2 + bx + c = 0\}$ ko'rinishda yozish mumkin.

Elementlari soniga bog'liq holda to'plamlar chekli va cheksiz to'plamlarga ajratiladi. Elementlari soni chekli bo'lgan to'plam *chekli to'plam*, elementlari soni cheksiz bo'lgan to'plam *cheksiz to'plam* deyiladi.

1- m i s o l. $A = \{x | x \in N, x^2 > 7\}$ to'plam 2 dan katta bo'lgan barcha natural sonlardan tuzilgan, ya'ni $A = \{3, 4, 5, 6, 7, 8, 9, \dots\}$. Bu to'plam – cheksiz to'plamdir.

Birorta ham elementga ega bo'lmagan to'plam *bo'sh to'plam* deyiladi. Bo'sh to'plam \emptyset orqali belgilanadi. Bo'sh to'plam ham chekli to'plam hisoblanadi.

2- m i s o l. $x^2 + 3x + 2 = 0$ tenglamaning ildizlari $X = \{-2; -1\}$ chekli to'plamni tashkil etadi. $x^2 + 3x + 3 = 0$ tenglama esa haqiqiy ildizlarga ega emas, ya'ni uning haqiqiy yechimlar to'plami \emptyset dir.

Ayni bir xil elementlardan tuzilgan to'plamlar *teng to'plamlar* deyiladi.

3- m i s o l. $X = \{x | x \in N, x \leq 3\}$ va $Y = \{x | (x - 1)(x - 2)(x - 3) = 0\}$ to'plamlarning har biri faqat 1, 2, 3 sonlaridan tuzilgan. Shuning uchun bu to'plamlar tengdir: $X = Y$.

Agar B to'plamning har bir elementi A to'plamning ham elementi bo'lsa, B to'plam A to'plamning *qism-to'plami* deyiladi va $B \subset A$ ko'rinishida belgilanadi. Bunda $\emptyset \subset A$ va $A \subset A$ hisoblanadi. Bu qism-to'plamlar *xosmas qism-to'plamlar* deyiladi. A to'plamning qolgan barcha qism-to'plamlari *xos qism-to'plamlar* deyiladi. Masalan: $N \subset Z \subset Q \subset R$. Agar $A = \{3, 4, 5\}$, $B = \{x | x^2 - 7x + 12 = 0\}$ bo'lsa, $B \subset A$ bo'ladi.

4- m i s o l. A – ikki xonali sonlar to'plami, B – ikki xonali juft sonlar to'plami bo'lsin. Har bir ikki xonali juft son A to'plamda ham mavjud. Demak, $B \subset A$.

$A = B$ bo'lsa, $A \subset B$, $B \subset A$ va aksincha, $A \subset B$, $B \subset A$ bo'lsa, $A = B$ bo'lishini tushunish qiyin emas.

5- misol. $A = \{1, 2, 3, 4\}$, $B = \{1, \frac{4}{2}, \sqrt{9}, 2^2\}$ bo'lsa,
 $B = \{1, \frac{4}{2}, \sqrt{9}, 2^2\} = \{1, 2, 3, 4\} = A$. Bundan ko'rinadiki, $A \subset B$,
 $B \subset A$ bo'ladi.

X chekli to'plam elementlari sonini $n(X)$ orqali belgilaymiz.
 k ta elementli X to'plamni k elementli to'plam deb ataymiz.

6- misol. X to'plam 10 dan kichik tub sonlar to'plami bo'lsin:
 $X = \{2; 3; 5; 7\}$. Demak, $n(X) = 4$.



Mashqlar

1.1. O'zbekiston Respublikasining Davlat gerbi qabul qilingan yilni ifodalovchi sonda qatnashgan raqamlar to'plamini tuzing.

1.2. $B = \{10; 12 \frac{3}{4}; 17,3; -7; 136\}$ to'plam berilgan. Qaysi natural sonlar bu to'plamga kiradi? Shu to'plamga tegishli bo'lmagan uchta son ayting. Javobni \in, \notin belgilari yordamida yozing.

1.3. S to'plam $-3; -2; -1; 4$ elementlaridan tuzilgan. Shu to'plamni yozing. Shu sonlarga qarama-qarshi sonlarning S_1 to'plamini tuzing.

1.4. „Bo'sh vaqtdan unumli foydalan“ jumlasidagi harflar to'plamini tuzing.

1.5. Quyidagi yozuvlarni o'qing va har bir to'plamning elementlarini ko'rsating:

a) $E = \{x | x \in N, -1 < x < 5\}$;

b) $F = \{x | 5x = x - 7\}$;

d) $Q = \{x | x(x+12) = 0\}$;

e) $U = \{x | x \in R, x^2 = 2\}$;

f) $V = \{x | x \in N, x^2 < 9\}$;

g) $W = \{x | x \in N, x^2 \leq 9\}$.

1.6. Quyidagi to'plamlarni son o'qida belgilang:

a) $\{x | x \in N, x \leq 3\}$;

b) $\{x | x \in Z, -2 \leq x \leq 2\}$;

d) $\{x | x \in R, x > 4, 1\}$;

e) $\{x | x \in R, -2, 7 \leq x \leq 1\}$;

f) $\{x | x \in R, x < 6\}$;

g) $\{x | x \in R, 3, 4 < x \leq 8\}$;

h) $\{x | x \in R, -3 \frac{1}{4} \leq x \leq -1\}$;

i) $\{x | x^2 = 4\}$;

j) $\{x | (x^2 - 1)(x^2 - 4) = 0\}$.

1.7. Quyidagi to'plam qaysi elementlardan tuzilgan:

- a) 1 va 3 bilangina yoziladigan barcha uch xonali sonlar to'plami;
- b) 1, 3, 5 raqamlaridan (faqat bir marta) foydalanib yoziladigan barcha uch xonali sonlar to'plami;
- d) raqamlarining yig'indisi 5 ga teng bo'lgan uch xonali sonlar to'plami;
- e) 100 dan kichik va oxirgi raqami 1 bo'lgan barcha natural sonlar to'plami?

1.8. Quyidagi to'plamlardan qaysilari bo'sh to'plam:

- a) simmetriya markaziga ega bo'lmagan kvadratlar to'plami;
- b) $\{x \mid x^2 + 1 = 0\}$;
- d) $\{x \mid x \in \mathbb{R}, |x| = 3\}$;
- e) $\{x \mid x \in \mathbb{R}, x^3 = 1\}$?

1.9. Quyidagi to'plamning nega bo'sh to'plam ekanligini tushuntiring:

- a) $\{x \mid x \in \mathbb{N}, x < -1\}$;
- b) $\{x \mid x \in \mathbb{N}, 15 < x < 16\}$;
- d) $\{x \mid x \in \mathbb{N}, x = \frac{3}{5}\}$;
- e) $\{x \mid x > 7, x < 5\}$.

1.10. Tenglamaning haqiqiy ildizlari to'plamini toping. Bu to'plamlarning qaysilari bo'sh to'plam ekanligini aniqlang:

- a) $3x + 15 = 4(x - 8)$;
- b) $2x + 4 = 4$;
- d) $2(x - 5) = 3x$;
- e) $x^2 - 4 = 0$;
- f) $x^2 + 16 = 0$;
- g) $(2x + 7)(x - 2) = 0$.

1.11. Quyidagi to'plam elementlarini va elementlar sonini ko'rsating:

- a) $\{l, f, g\}$; b) $\{a\}$; d) $\{\{a\}\}$; e) \emptyset ; f) $\{\emptyset\}$; g) $\{\{a, b\}, \{c, d\}\}$; h) $\{\{a, b, c\}, a\}$.

1.12. 5 ta elementi bor bo'lgan to'plam tuzing.

1.13. 5 ta natural son qatnashgan sonli to'plam tuzing.

1.14. $A = \{a, b, c, d, e, f, g, k\}$, $B = \{a, l, k\}$, $C = \{b, d, g, k, t\}$, $D = \{a, l\}$, $E = \{e, f, k, g\}$ to'plamlar berilgan.

- a) Ularning qaysilari A to'plamning xoc qism-to'plami bo'ladi?
- b) D to'plam C to'plamning qism-to'plamimi?
- d) B to'plam qaysi to'plamning qism-to'plami bo'ladi?
- e) $n(A)$, $n(B)$, $n(C)$, $n(D)$, $n(E)$ sonlarni o'sish tartibida joylashtiring.

1.15. $A = \{3, 6, 9, 12\}$ to'plamning barcha qism-to'plamlarini tuzing.

1.16. To'plamlar jufti berilgan:

- a) $A = \{\text{Navoiy, Bobur, Furqat, Nodirabegim}\}$ va B – barcha shoir va shoirlar to'plami;
 - b) C – qavariq to'rtburchaklar to'plami va D – to'rtburchaklar to'plami;
 - d) E – Samarqand olimlari to'plami, F – O'zbekiston olimlari to'plami;
 - e) K – barcha tub sonlar to'plami, M – manfiy sonlar to'plami.
- Juftlikdagi to'plamlardan qaysi biri ikkinchisining qism-to'plami bo'lishini aniqlang.

1.17. Quyidagi to'plamlar uchun $A \subset B$ yoki $B \subset A$ munosabatlardan qaysi biri o'rinli:

- a) $A = \{a, b, c, d\}$, $B = \{a, c, d\}$;
- b) $A = \{a, b\}$, $B = \{a, c, d\}$;
- d) $A = \emptyset$, $B = \emptyset$;
- e) $A = \emptyset$, $B = \{a, b, c\}$;
- f) $A = \emptyset$, $B = \{\emptyset\}$;
- g) $A = \{\{a\}, a, \emptyset\}$, $B = \{a\}$;
- h) $A = \{\{a, b\}, \{c, d\}, c, d\}$, $B = \{\{a, b\}, c\}$;
- i) $A = \{\{0\}, 0\}$, $B = \{\emptyset, \{\{0\}, 0\}\}$?

1.18. Munosabatning to'g'ri yoki noto'g'ri ekanligini aniqlang:

- a) $\{1; 2\} \subset \{\{1; 2; 3\}; \{1; 3\}; 1; 2\}$;
- b) $\{1; 2\} \in \{\{1; 2; 3\}; \{1; 3\}; 1; 2\}$;
- d) $\{1; 3\} \subset \{\{1; 2; 3\}; \{1; 3\}; 1; 2\}$;
- e) $\{1; 3\} \in \{\{1; 2; 3\}; \{1; 3\}; 1; 2\}$.

1.19. Quyidagi to'plamlar tengmi:

- a) $A = \{2; 4; 6\}$ va $B = \{6; 4; 2\}$;

b) $A = \{1; 2; 3\}$ va $B = \{1; 11; 111\}$;

d) $A = \{\{1; 2\}, \{2; 3\}\}$ va $B = \{2; 3; 1\}$;

e) $A = \{\sqrt{256}; \sqrt{81}; \sqrt{16}\}$ va $B = \{2^2; 3^2; 4^2\}$?

1.20. $x = \{x | x^2 - 5x + 6 = 0\}$ va $A \{2; 3\}$ to'plamlar haqida nima deyish mumkin?

2. To'plamlar ustida amallar. A va B to'plamlarning ikkalasida ham mavjud bo'lgan x elementga shu to'plamlarning *umumiy elementi* deyiladi. A va B to'plamlarning *kesishmasi* (yoki *ko'paytmasi*) deb, ularning barcha umumiy elementlaridan tuzilgan to'plamga aytiladi. A va B to'plamlarning kesishmasi $A \cap B$ ko'rinishda belgilanadi: $A \cap B = \{x | x \in A \text{ va } x \in B\}$. 1- rasmda Eyler – Venn diagrammasi nomi bilan ataladigan chizmada A va B shakllarning kesishmasi $A \cap B$ ni beradi (chizmada shtrixlab ko'rsatilgan).

A va B to'plamlarning *birlashmasi* (yoki *yig'indisi*) deb, ularning kamida bittasida mavjud bo'lgan barcha elementlardan tuzilgan to'plamga aytiladi. A va B to'plamlarning birlashmasi $A \cup B$ ko'rinishida belgilanadi: $A \cup B = \{x | x \in A \text{ yoki } x \in B\}$ (2- rasm).

A va B to'plamlarning *ayirmasi* deb, A ning B da mavjud bo'lmagan barcha elementlaridan tuzilgan to'plamga aytiladi. A va B to'plamlarning ayirmasi $A \setminus B$ ko'rinishda belgilanadi: $A \setminus B = \{x | x \in A \text{ va } x \notin B\}$ (3- rasm).

Topshiriq: 3- a rasmda $B \setminus A$ ni ko'rsating.

Agar $B \subset A$ bo'lsa, $A \setminus B$ to'plam B to'plamning *to'ldiruvchisi* deyiladi va B' yoki B_A' bilan belgilanadi (3- b rasm).

1- misol. $A = \{a, b, c, d, e, f\}$ va $B = \{b, d, e, g, h\}$ to'plamlar berilgan. Ularning kesishmasi, birlashmasini topamiz va Eyler – Venn diagrammasida talqin etamiz.

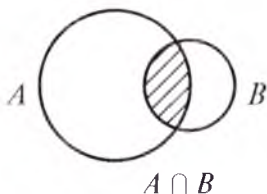

1- rasm.

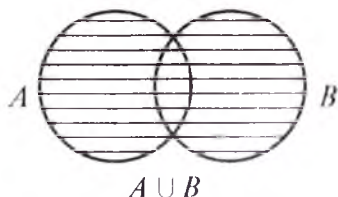

2- rasm.

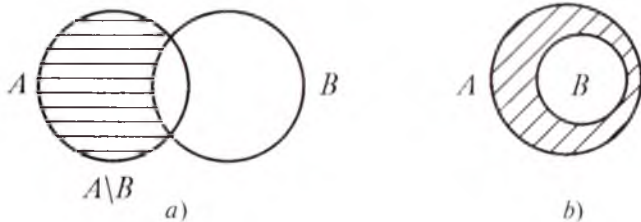

3- rasm.

b, d, e elementlari A va B to'plamlar uchun umumiy, shunga ko'ra $A \cap B = \{b, d, e\}$. Bu to'plamlarning birlashmasi esa $A \cup B = \{a, b, c, d, e, f, h\}$ dan iborat (4- a rasm).

2- misol. $A = \{x \mid -\frac{2}{3} \leq x \leq \frac{7}{4}\}$, $B = \{x \mid -\frac{1}{4} \leq x \leq 2\}$ to'plamlarning kesishmasi, birlashmasi va ayirmasini topamiz. Buning uchun sonlar o'qida $-\frac{2}{3}, -\frac{1}{4}, \frac{7}{4}, 2$ nuqtalarni belgilaymiz (4- rasm). $A \cap B = \{x \mid -\frac{1}{4} \leq x \leq \frac{7}{4}\}$, $A \cup B = \{x \mid -\frac{2}{3} \leq x \leq 2\}$, $A \setminus B = \{x \mid -\frac{2}{3} \leq x < -\frac{1}{4}\}$.

3- misol. $A = \{0; 2; 3\}$, $C = \{0; 1; 2; 3; 4\}$ to'plamlar uchun $A' = C \setminus A$ ni topamiz. $A \subset C$ bo'lgani uchun $A' = C \setminus A = \{1; 4\}$ bo'ladi.

4- misol. Agar $A \subset B$ bo'lsa, $A \cup B = B$ bo'lishini isbot qilamiz.

Isbot. $A \subset B$ bo'lsin.

a) $A \cup B \subset B$ ni ko'rsatamiz. $x \in A \cup B$ bo'lsin. U holda $x \in A$ yoki $x \in B$ bo'ladi. Agar $x \in A$ bo'lsa, $A \subset B$ ekanidan $x \in B$ ekani kelib chiqadi, ikkala holda ham $A \cup B$ ning har qanday elementi B ning ham elementidir. Demak, $A \cup B \subset B$;

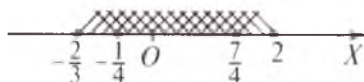
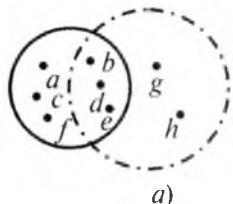

4- rasm.

b) $B \subset A \cup B$ ni ko'rsatamiz. $x \in B$ bo'lsin. U holda, to'plamlar birlashmasining ta'rifiga ko'ra $x \in A \cup B$ bo'ladi. Demak, B ning har qanday elementi $A \cup B$ ning ham elementi bo'ladi, ya'ni $B \subset A \cup B$.

Shunday qilib, $A \cup B \subset B$, $B \subset A \cup B$. Bu esa $B = A \cup B$ ekanini tasdiqlaydi.

To'plamlar ustida bajariladigan amallarning xossalari sonlar ustida bajariladigan amallarning xossalriga o'xshash. Har qanday X , Y va Z to'plamlar uchun:

$$1) X \cup Y = Y \cup X;$$

$$1') X \cap Y = Y \cap X;$$

$$2) (X \cup Y) \cup Z = X \cup (Y \cup Z) = (X \cup Z) \cup Y;$$

$$2') (X \cap Y) \cap Z = (X \cap Z) \cap Y = X \cap (Y \cap Z);$$

$$3) (X \cup Y) \cap Z = (X \cap Z) \cup (Y \cap Z);$$

$$3') (X \cap Y) \cup Z = (X \cup Z) \cap (Y \cup Z) \text{ tengliklar bajariladi.}$$

Agar qaralayotgan to'plamlar ayni bir U to'plamning qism-to'plamlari bo'lsa, U to'plam *universal* to'plam deyiladi.

Universal to'plam qism-to'plamlarining kesishmasi, birlashmasi, shuningdek, U to'plam ixtiyoriy qism-to'plamining to'ldiruvchisi ham U ning qism to'plami bo'ladi. Biror X to'plamning U ga to'ldiruvchisini X'_U yoki X' shaklida belgilash mumkin.

To'ldirish amalining ayrim xossalarini ko'rsatib o'tamiz:

1) $\emptyset' = U$, 2) $U' = \emptyset$, 3) $(X')' = X$, 4) U dan olingan har qanday X va Y to'plam uchun $(X \cap Y)' = X' \cup Y'$; $(X \cup Y)' = X' \cap Y'$.

Shuningdek, agar $X \subset Y$ bo'lsa, $X \cap Y = X$, $X \cup Y = Y$ bo'ladi. Xususan, $\emptyset \subset X$ va $X \subseteq X$ bo'lganidan, $\emptyset \cap X = \emptyset$, $\emptyset \cup X = X$, $X \cap X = X$, $X \cup X = X$ bo'ladi.

5- misol. $A = \{1, 2, 3, 4\}$, $B = \{1, 3, 5\}$, $C = \{1, 5, 9\}$ to'plamlar berilgan. $D = \{1, 2, 3, 4, 5, 9\}$ to'plam universal to'plam bo'ladimi? $E = \{1, 2, 3, 4, 5, 9, 15\}$ va $M = \{1, 3, 4, 5, 9\}$ to'plamlar-chi?

$A \subset D$, $B \subset D$, $C \subset D$ bo'lgani uchun D to'plam universal to'plam bo'ladi. $D \subset E$ bo'lgani uchun E to'plam ham universal to'plam bo'ladi. $B \subset M$, $C \subset M$, lekin $A \not\subset M$ bo'lgani uchun M to'plam universal to'plam bo'la olmaydi.



Mashqlar

- 1.21. $M = \{36; 29; 15; 68; 27\}$, $P = \{4; 15; 27; 47; 36; 90\}$, $Q = \{90; 4; 47\}$ to'plamlar berilgan. $M \cap P$, $M \cap Q$, $P \cap Q$, $M \cap P \cap Q$ larni toping.
- 1.22. A – 18 ning hamma natural bo'luvchilari to'plami, B – 24 ning hamma natural bo'luvchilari to'plami. $A \cap B$ to'plam elementlarini ko'rsating.
- 1.23. P ikki xonali natural sonlar to'plami, S barcha toq natural sonlar to'plami bo'lsa, $K = P \cap S$ to'plamga qaysi sonlar kiradi?
 a) $21 \in K$; b) $32 \in K$; d) $7 \notin K$; e) $17 \notin K$ deyish to'g'rimi?
- 1.24. „Matematika“ va „grammatika“ so'zlaridagi harflar to'plamini tuzing. Bu to'plamlar kesishmasini toping.
- 1.25. $[1; 5]$ va $[3; 7]$ kesmalarning kesishmasini toping.
- 1.26. $P = \{a, b, c, d, e, f\}$ va $E = \{a, g, z, e, k\}$ to'plamlar birlashmasini toping.
- 1.27. $A = \{n \mid n \in \mathbb{N}, n < 5\}$ va $B = \{n \mid n \in \mathbb{N}, n > 7\}$ to'plamlar birlashmasini toping. a) $4 \in A \cup B$; b) $-3 \in A \cup B$; d) $6 \in A \cup B$ deyish to'g'rimi?
- 1.28. Agar a) $A = \{x \mid x = 8k, k \in \mathbb{Z}\}$, $B = \{x \mid x = 8l - 4, l \in \mathbb{Z}\}$; b) $A = \{x \mid x = 6k - 1, k \in \mathbb{Z}\}$, $B = \{x \mid x = 6l + 4, l \in \mathbb{Z}\}$ bo'lsa, $A \cup B$ ni toping.
- 1.29. $A = \{2; 4; 6; 8; \dots; 40\}$, $B = \{1; 3; 5; 7; \dots; 37\}$, $C = \{\{a; b\}, \{c; d\}, \{e; f\}, g, h\}$ to'plamlarning har biridagi elementlar sonini aniqlang. $A \cup B$ da nechta element mavjud?
- 1.30. $A = \{2; 3; 4; 5; 7; 10\}$, $B = \{3; 5; 7; 9\}$, $C = \{4; 9; 11\}$ bo'lsin. Quyidagi to'plamlarda nechtadan element mavjud:
 a) $A \cup (B \cup C)$; b) $(C \cup B) \cup A$; d) $A \cap (B \cup C)$;

e) $A \cup (B \cap C)$; f) $A \cap (B \cap C)$; g) $B \cap (A \cup C)$?

1.31. $A = \{x \mid -5 \leq x \leq 10\}$, $B = \{x \mid x \in \mathbb{N}, 3 \leq x \leq 15\}$ bo'lsin. $A \setminus B$ va $B \setminus A$ to'plam elementlarini toping.

1.32. P – ikki xonali natural sonlar to'plami, Q – juft natural sonlar to'plami bo'lsin. $P \setminus Q$ va $Q \setminus P$ to'plamlarni tuzing.

1.33. C va D kesishuvchi to'plamlar bo'lsin. Eylar – Venn diagrammalari yordamida $C \setminus D$, $D \setminus C$, $(C \setminus D) \cup (D \setminus C)$ larni tasvirlang.

1.34. N' bilan natural sonlar to'plami N ning butun sonlar to'plami Z ga to'ldiruvchisini belgilaymiz. Quyidagilar to'g'rimi:

a) $-4 \in N'$; b) $0 \in N'$; d) $13 \in N'$;
e) $-8 \notin N'$; f) $-5, 3 \notin N'$; g) $0 \notin N'$?

1.35. $A = \{x \mid x = 2k + 1, k \in \mathbb{Z}\}$ to'plamning Z to'plamga to'ldiruvchisini toping.

1.36. $A = \{x \mid x = 3k, k \in \mathbb{Z}\}$ to'plamning Z to'plamga to'ldiruvchisini toping.

1.37. Agar $A \subset U$, $B \subset U$ bo'lsa, quyidagi tengliklar o'rinli bo'lishini isbotlang:

a) $(A \cup B)' = A' \cap B'$, b) $(A \cap B)' = A' \cup B'$.

1.38. Agar A to'plam $x^2 - 7x + 6 = 0$ tenglamaning yechimlari to'plami va $B = \{1; 6\}$ bo'lsa, $A = B$ bo'lishini isbotlang.

1.39. $A \setminus B = A \setminus (A \cap B)$ tenglikni isbotlang.

1.40. $A \cap (B \setminus A) = \emptyset$ tenglikni isbotlang.

1.41. $A \subset U$, $B \subset U$, $A \cap B = \emptyset$ bo'lsin. Quyidagilarni Eylar – Benn diagrammalari yordami bilan tasvirlang va ulardan tenglarini ko'rsating:

1) $(A' \cap B)'$; 2) $A' \cap B'$; 3) $A' \cap B$;
4) $A \cup B'$; 5) $(A' \cup B)'$; 6) $A' \cup B'$.

1.42. a) Munosabatlarni isbot qiling:

1) $(A \cup B) \setminus B = A$;
2) $(A \setminus B) \cup (B \setminus A) = (A \cup B) \setminus (A \cap B)$;

$$3) A \cup (B \cap C) = (A \cup B) \cap (A \cup C);$$

$$4) (A \cup B) \setminus C = (A \setminus C) \cup (B \setminus C);$$

b) A va B lar U universal to'plamning qism-to'plamlari. Isbot qiling:

$$1) (A \cap B)' = A' \cup B'; \quad 2) (A \cap B) = A \setminus (A \cap B').$$

1.43. Ifodalarni soddalashtiring:

$$1) B \cap (A \cup B); \quad 2) (A \cap B) \cap (A' \cap B).$$

3. To'plam elementlarining soni bilan bog'liq ayrim masalalar.

To'plamlar nazariyasining muhim qoidalaridan biri — jamlash qoidasidir. Bu qoida kesishmaydigan to'plamlar birlashmasidagi elementlar sonini topish imkonini beradi.

1- te o r e m a (jamlash qoidasi). *Kesishmaydigan A va B chekli to'plamlarning (5- rasm) birlashmasidagi elementlar soni A va B to'plamlar elementlari sonlarining yig'indisiga teng:*

$$n(A \cup B) = n(A) + n(B).$$

Isbot. $n(A) = k$, $n(B) = m$ bo'lib, A to'plam a_1, a_2, \dots, a_k elementlardan, B to'plam esa b_1, b_2, \dots, b_m elementlardan tashkil topgan bo'lsin.

Agar A va B to'plamlar kesishmasa, ularning birlashmasi $a_1, a_2, \dots, a_k, b_1, b_2, \dots, b_m$ elementlardan tashkil topadi:

$$A \cup B = \{a_1, a_2, \dots, a_k, b_1, b_2, \dots, b_m\}.$$

Bu to'plamda $k + m$ ta element mavjud, ya'ni

$$n(A \cup B) = k + m = n(A) + n(B).$$

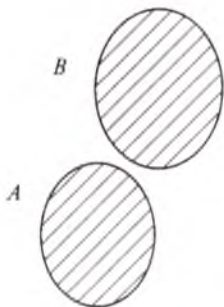

5- rasm.

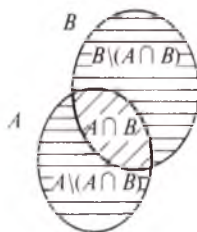

6- rasm.

Xuddi shu kabi, chekli sondagi A, B, \dots, F juft-jufti bilan kesishmaydigan to'plamlar uchun quyidagi tenglik to'g'riligini isbotlash mumkin:

$$n(A \cup B \cup \dots \cup F) = n(A) + n(B) + \dots + n(F).$$

2- teorema. Ixtiyoriy A va B chekli to'plamlar uchun ushbu tenglik o'rinli:

$$n(A \cup B) = n(A) + n(B) - n(A \cap B). \quad (1)$$

I s b o t. Agar $A \cap B = \emptyset$ bo'lsa, $n(A \cap B) = 0$ bo'lib, 1- teoremaga ko'ra (1) tenglik o'rinli. Agar $A \cap B \neq \emptyset$ bo'lsa, u holda $A \cup B$ to'plamni uchta juft-jufti bilan kesishmaydigan to'plamlarning birlashmasi ko'rinishida tasvirlash mumkin (6- rasm):

$$A \cup B = (A \setminus (A \cap B)) \cup (B \setminus (A \cap B)) \cup (A \cap B). \quad (2)$$

$A \setminus (A \cap B)$, $B \setminus (A \cap B)$ va $A \cap B$ to'plamlardagi elementlari soni mos ravishda $n(A) - n(A \cap B)$, $n(B) - n(A \cap B)$, $n(A \cap B)$ ga teng.

Jamlash qoidasiga ko'ra, (2) tenglikdan

$n(A \cup B) = (n(A) - n(A \cap B)) + (n(B) - n(A \cap B)) + n(A \cap B) = n(A) + n(B) - n(A \cap B)$, ya'ni (1) tenglik hosil bo'ladi.

M a s a l a. 100 kishidan iborat sayyohlar guruhida 70 kishi ingliz tilini, 45 kishi fransuz tilini, 23 kishi esa ikkala tilni ham biladi. Sayyohlar guruhidagi necha kishi ingliz tilini ham, fransuz tilini ham bilmaydi?

Y e c h i s h. Berilgan guruhdagi ingliz tilini biladigan sayyohlar to'plamini A bilan, fransuz tilini biladigan sayyohlar to'plamini B bilan belgilaymiz. U holda ham ingliz tilini, ham fransuz tilini biladigan sayyohlar to'plami $A \cap B$ to'plamdan, shu ikki tildan hech bo'lmasa bittasini biladigan sayyohlar to'plami esa $A \cup B$ to'plamdan iborat bo'ladi.

Shartga ko'ra, $n(A) = 70$, $n(B) = 45$, $n(A \cap B) = 23$. (1) tenglikka ko'ra, $n(A \cup B) = 70 + 45 - 23 = 92$.

Shunday qilib, 92 kishi ingliz va fransuz tillaridan hech bo'lmaganda bittasini biladi, $100 - 92 = 8$ kishi esa ikkala tilni ham bilmaydi.



Mashqlar

- 1.44. Sinfdagi bir necha o'quvchi marka yig'dilar. 15 o'quvchi O'zbekiston markalarini, 11 kishi chet el markalarini, 6 kishi ham O'zbekiston markalarini, ham chet el markalarini yig'di. Sinfda necha o'quvchi marka to'plagan?
- 1.45. 32 o'quvchining 12 tasi voleybol seksiyasiga, 15 tasi basketbol seksiyasiga, 8 kishi esa ikkala seksiyaga ham qatnashadi. Sinfdagi necha o'quvchi hech bir seksiyaga qatnashmaydi?
- 1.46. 30 o'quvchidan 18 tasi matematikaga, 17 tasi esa fizikaga qiziqadi. Ikkala fanga ham qiziqadigan o'quvchilar soni nechta bo'lishi mumkin? (K o' r s a t m a. Ikkala fanga ham qiziqmaydigan o'quvchilar soni $k \in \{0, 1, 2, 3, \dots, 12\}$).
- 1.47. 100 odamdan iborat sayyohlar guruhida 10 kishi nemis tilini ham, fransuz tilini ham bilmaydi, 75 tasi nemis tilini, 83 tasi esa fransuz tilini biladi. Ikkala tilni ham biladigan sayyohlar sonini toping.
- 1.48. 26 o'quvchining 14 tasi shaxmatga, 16 tasi shashkaga qiziqadi. Ham shashkaga, ham shaxmatga qiziqadigan o'quvchilar nechta?

2- §. Matematik mantiq elementlari

Matematik mantiq matematikaning bir bo'limi bo'lib, unda „mulohaza“lar va ular ustidagi mantiqiy amallar o'rganiladi.

Chin yoki *yolg'onligi* haqida fikr yuritish mumkin bo'lgan har qanday darak gap *mulohaza* deyiladi. Mulohazalar ustida bajariladigan mantiqiy amallar maxsus belgilar yordamida ifodalanadi. Bu belgilar hozirgi zamon matematikasining barcha bo'limlarida qo'llaniladi.

Bu belgilar quyidagilardir:

1) \Rightarrow — agar ... bo'lsa, u holda ... bo'ladi,

$P \Rightarrow Q$ — agar P bo'lsa, Q bo'ladi (P dan Q kelib chiqadi);

2) \Leftrightarrow — teng kuchlilik,

$P \Leftrightarrow Q$ — P va Q teng kuchli (P dan Q kelib chiqadi va aksincha);

- 3) \vee – dizyunksiya („yoki“ amali);
- 4) \wedge – konyunksiya („va“ amali);
- 5) \forall – ixtiyoriy, barcha, har qanday;
- 6) \exists – shunday, mavjud;
- 7) \nexists – mavjud emas.

Bu amallarni (belgilarni) qo'llashga doir misollar keltiramiz.

$P = \{a \text{ soni } 15 \text{ ga bo'linadi}\}$ va $Q = \{a \text{ soni } 5 \text{ ga bo'linadi}\}$ mulohazalari quyidagicha bog'langan:

P mulohazaning chinligidan Q mulohazaning chinligi kelib chiqadi. Mulohazalarning bunday bog'lanishi *mantiqiy kelib chiqish* deyiladi va \Rightarrow belgi yordamida yoziladi: $P \Rightarrow Q$.

Bu yerda „ a soni 15 ga bo'linadi“ sharti a sonining 5 ga bo'linishi uchun *yetarlidir* . Shu bilan birga, „ a soni 5 ga bo'linadi“ sharti uning 15 ga bo'linishi uchun yetarli emas, u *zaruriy* shartdir xolos, chunki a soni 5 ga bo'linmasa, uning 15 ga bo'linishi mumkin emas.

Umuman, P mulohazaning chinligidan Q mulohazaning chinligi kelib chiqsa ($P \Rightarrow Q$), P mulohaza Q mulohaza uchun yetarli shart va Q mulohaza P mulohaza uchun zaruriy shart deyiladi.

Agar $A \Rightarrow B$ va $B \Rightarrow A$ bo'lsa, B mulohaza A mulohaza uchun zaruriy va yetarli shartdir. Bu esa quyidagicha yoziladi: $A \Leftrightarrow B$. „ \Leftrightarrow “ – mantiqiy teng kuchlilik belgisidir.

A – „ a soni juft son“ mulohazasi bo'lsin.

B – „ a^2 – juft son“ mulohazasi bo'lsin.

Bu mulohazalar teng kuchli mulohazalar bo'ladi, ya'ni $A \Leftrightarrow B$.

Boshqacha aytganda, sonning kvadrati juft son bo'lishi uchun sonning o'zi juft bo'lishi zarur va yetarli.

Biror A mulohazaning *inkori* deb, A chin bo'lganda yolg'on, A yolg'on bo'lganda esa chin bo'ladigan mulohazaga aytiladi va \bar{A} bilan belgilanadi.

A – „yetti – murakkab son“, u holda \bar{A} „yetti – murakkab son emas“. Bu yerda A – yolg'on, \bar{A} – chin mulohazadir.

A va B mulohazalarning *dizyunksiyasi* deb, A va B mulohazalardan kamida bittasi chin bo'lganda chin bo'ladigan yangi mulohazaga aytiladi va $A \vee B$ bilan belgilanadi.

Masalan, A – „ $6 \cdot 4 = 24$ “, B = „ $6 \cdot 4 = 25$ “ bo'lsa, $A \vee B$ mulohaza „ $6 \cdot 4$ ko'paytma 24 yoki 25 ga teng“.

A va B mulohazalarning konyunksiyasi deb, bu ikkala mulohaza ham chin bo'lgandagina chin bo'ladigan yangi mulohazaga aytiladi va $A \wedge B$ bilan belgilanadi.

Masalan, C — „13 soni toq va tubdir“ mulohazasi quyidagi ikkita mulohazaning konyunksiyasidir. A — „13 soni — toq“, B — „13 soni — tub“. Demak, $C = A \wedge B$.

Matematik mulohazalarni yuqoridagi belgilar yordamida ifoda etishga doir misollar keltiramiz.

1- misol. Agar $a > b$ va $b > c$ bo'lsa, $a > c$ bo'ladi. $(a > b) \wedge (b > c) \Rightarrow (a > c)$.

2- misol. $a > b$ bo'lsa, $a + c > b + c$ bo'ladi. $(a > b) \Rightarrow (a + c > b + c)$.

3- misol. $a = 0$ yoki $b = 0$ bo'lsa, $ab = 0$ bo'ladi va aksincha, $ab = 0$ bo'lsa, $a = 0$ yoki $b = 0$ bo'ladi. $(ab = 0) \Leftrightarrow ((a = 0) \vee (b = 0))$.

4- misol. $a > 0$ va $b > 0$ bo'lsa, $ab > 0$ bo'ladi. $(a > 0) \wedge (b > 0) \Rightarrow (ab > 0)$.

5- misol. Ixtiyoriy x haqiqiy son uchun $|x| \geq x$. $\forall x \in \mathbb{R}: |x| \geq x$.

6- misol. Ixtiyoriy $a \geq 0$ son uchun, shunday $x \in \mathbb{R}$ son mavjudki, $x^2 = a$ bo'ladi, ya'ni $\forall a \geq 0, \exists x \in \mathbb{R}: x^2 = a$.



Mashqlar

Jumlalarni yuqoridagi belgilar yordamida yozing.

1.49. Ixtiyoriy $a \geq 0$ uchun, $\sqrt{a} = x$ tenglik o'rinli bo'ladigan x haqiqiy son mavjud bo'ladi.

1.50. $a < 0$ va $b > 0$ bo'lsa, $ab < 0$ bo'ladi.

1.51. Har qanday a, b haqiqiy sonlar uchun $a + b = b + a$ bo'ladi.

1.52. Agar a butun son 9 ga bo'linsa, u holda bu son 3 ga ham bo'linadi.

1.53. 2 ga ham, 3 ga ham bo'linadigan butun son 6 ga ham bo'linadi va aksincha, 6 ga bo'linadigan butun son 2 ga ham, 3 ga ham bo'linadi.

1.54. Agar $a^2 + b^2 + c^2 = 0$ bo'lsa, $a = b = c = 0$ bo'ladi va aksincha, $a = b = c = 0$ bo'lsa, $a^2 + b^2 + c^2 = 0$ bo'ladi.

- 1.55. Ixtiyoriy natural son n ni olmaylik, $n = 2k - 1$ yoki $n = 2k$ bo'ladigan k natural son mavjud bo'ladi.
- 1.56. Ixtiyoriy n natural son uchun $n^2 + n^3 \in N$ bo'ladi.
- 1.57. Ixtiyoriy n, k natural sonlari uchun $n^2 - k^3$ soni butun son bo'ladi.
- 1.58. $a < 0$ bo'lsa, $x^2 = a$ tenglik to'g'ri bo'ladigan haqiqiy x son mavjud emas.



Takrorlashga doir mashqlar

1.59. To'plamlar kesishmasini va birlashmasini toping. Eylar — Venn diagrammasi yordamida grafik talqin qiling.

- a) $A = \{5, 6, 7, 8, 9, 10\}$, $B = \{8, 9, 10, 11\}$;
- b) $A = \{x \mid x = 2n, n \in N\}$, $B = \{x \mid x = \frac{n+1}{2}, n \in N\}$;
- d) $A = \{x \mid x = 5n, n \in N\}$, $B = \{x \mid x = 2n, n \in N\}$;
- e) $A = \{x \mid x = \frac{1}{n}, n \in N\}$, $B = \{x \mid x = \frac{2}{n}, n \in N\}$.

1.60. P va Q to'plamlar kesishmasi va birlashmasini sonlar to'g'ri chizig'ida tasvirlang:

- a) $P = \{x \mid \frac{10}{3} < x < \sqrt{8}\}$, $Q = \{x \mid \frac{26}{47} < x < 3,2\}$;
- b) $P = \{x \mid -\frac{1}{3} < x < \frac{5}{3}\}$, $Q = \{x \mid \sqrt{2} < x \leq \frac{40}{27}\}$;
- d) $P = \{x \mid \frac{11}{4} \leq x \leq \frac{19}{3}\}$, $Q = \{x \mid \frac{19}{7} < x \leq \frac{32}{5}\}$;
- e) $P = \{x \mid \frac{4}{11} \leq x < \frac{18}{5}\}$, $Q = \{x \mid \sqrt{2} < x < 10\}$.

1.61. Quyidagi tengliklarni isbotlang:

- a) $A \cup B = B \cup A$;
- b) $(A \cup B) \cup C = A \cup (B \cup C)$;
- d) Agar $A \subset B$ bo'lsa, $A \cup B = B$;
- e) $A \cup \emptyset = A$;
- f) $A \cup A = A$.

1.62. Quyidagi tengliklarni isbotlang:

- a) $A \cap B = B \cap A$;
- b) $(A \cap B) \cap C = A \cap (B \cap C)$;
- d) $A \cap A = A$;
- e) $A \cap \emptyset = \emptyset$.

1.63. $(A \cap B) \cup C = (A \cup C) \cap (B \cup C)$ tenglik to'plamlarni ko'paytirish amalining to'plamlarni qo'shish amaliga nisbatan distributivlik xossasini, $(A \cup B) \cap C = (A \cap C) \cap (B \cap C)$ tenglik esa to'plamlarni qo'shish amalining to'plamlarni ko'paytirish amaliga nisbatan distributivlik xossasini ifodalaydi. Bu xossalarni isbotlang.

1.64. Ayirish va to'ldirish amallarining quyidagi xossalarni isbotlang ($A \subset B$, $B \subset C$, $C \subset U$ deb hisoblang):

- a) $A' \cap A = \emptyset$;
- b) $A' \cup A = U$;
- d) $(A \cap B)' = A' \cup B'$;
- e) $\emptyset' = U$;
- f) $U' = \emptyset$;
- g) $(A \setminus B) \setminus C = A \setminus (B \cup C)$.

1.65. \emptyset , \cup , \cap , \subset belgilardan foydalanib, to'plamlar orasidagi munosabatni yozing:

- a) $X_1 = \{-5; 6\}$, $X_2 = \{x \mid x \in \mathbb{Z}, -5 \leq x \leq 6\}$,
 $X_3 = \{x \mid x \in \mathbb{Z}, -5 < x < 6\}$,
 $X_4 = \{x \mid x \in \mathbb{Q}, -5 \leq x \leq 6\}$;
- b) $A = \{1; 3; 5; 7\}$, $B = \{1; 5; 7\}$;
- d) $A = \{\{0\}; 1; 3\}$, $B = \{1; 3\}$;
- e) $A = \emptyset$, $B = \{k, l, m\}$;
- f) $A = \{x, y, z\}$, $B = \{y, z, x\}$;
- g) $A = \{0\}$, $B = \emptyset$;
- h) $A = \{\{x\}, x, \emptyset\}$, $B = \{x\}$;
- i) $A = \{\{1; 3\}; \{2; 4\}; 2; 4\}$, $B = \{\{1; 3\}, 2\}$;
- j) $A = \{\{3\}, 3, \emptyset\}$, $B = \emptyset$.

1.66. a) $A = \{2n - 1 \mid n \in \mathbb{N}\}$, $B = \{4n + 1 \mid n \in \mathbb{N}\}$, $C = \{3n + 1 \mid n \in \mathbb{N}\}$ bo'lsin. Ushbu to'plamlarni toping:

- 1) $A \cap B$; 2) $A \cap C$; 3) $A \cap B \cap C$; 4) $(A \cap B) \cup C$;
- b) quyidagi munosabatlar to'g'rimi:
1) $\{a, c\} \subset \{\{a, b, c\}, \{a, c\}, a, b\}$;

2) $\{a, b, c\} \in \{\{a, b, c, d\}, \{a, c\}, a, b\}$;

3) $\{1, 2, 3\} \subset \{\{1, 2, 3, 4\}, \{1; 3\}, 1, 2\}$?

1.67. a) sonli to'plamlarni toping:

1) $\{(-1)^n - 1 | n \in \mathbb{N}\}$; 2) $\{1 - (-1)^n \cdot 2 | n \in \mathbb{N}\}$;

b) agar $A = \{-2; -1; 0; 1; 2; 3; 4; 5\}$, $B = \{3; 4; 5; 6\}$,

$C = \{-3; -2; -1; 0; 2; 3\}$, $D = \{2; 3; 4; 5; 6; 7\}$,

$M = \{5 \leq x - 10 \leq 12 | x \in \mathbb{N}\}$, $K = \{x + 10 \leq 30 | x \in \mathbb{N}\}$

bo'lsa, quyidagi to'plamlar elementlarini ko'rsatib yozing:

1) $(A \cup B) \cap (C \cup D)$; 2) $(A \cap B \cap C) \cup D$;

3) $(A \cap B) \cup (C \cap D) \cup M$; 4) $(A \cup C) \cap (A \cup B)$;

5) $(B \setminus A) \cup (A \setminus B)$; 6) $D'_B \cup (C \setminus D)$;

7) $M \cap N$; 8) $M \cup N$.



II bob

HAQIQIY SONLAR

1- §. Natural sonlar

1. Tub va murakkab sonlar. Narsalarni sanashda ishlatiladigan sonlar *natural sonlar* deyiladi. Barcha natural sonlar hosil qilgan cheksiz to'plam N harfi bilan belgilanadi: $N = \{1, 2, \dots, n, \dots\}$.

Natural sonlar to'plamida eng katta son (element) mavjud emas, lekin eng kichik son (element) mavjud, u 1 soni. 1 soni faqat 1 ta bo'luvchiga ega (1 ning o'zi). 1 dan boshqa barcha natural sonlar kamida ikkita bo'luvchiga ega (sonning o'zi va 1).

1 dan va o'zidan boshqa natural bo'luvchiga ega bo'lmagan 1 dan katta natural son *tub son* deyiladi. Masalan, 2, 3, 5, 7, 11, 13, 17, 19 sonlar 20 dan kichik bo'lgan barcha tub sonlardir. 1 dan va o'zidan boshqa natural bo'luvchiga ega bo'lgan 1 dan katta natural son *murakkab son* deyiladi. Masalan, 4, 6, 8, 9, 10, 12, 14, 15, 16, 18 sonlar 20 dan kichik bo'lgan barcha murakkab sonlardir.

Tub va murakkab sonlarga berilgan ta'riflardan 1 soni na tub, na murakkab son ekanligi ma'lum bo'ladi. Bunday xossaga ega natural son faqat 1 ning o'zidir.

Natural sonlarning ayrim xossalarini qaraymiz.

1- x o s s a. Har qanday $p > 1$ natural sonining 1 ga teng bo'lmagan bo'luvchilarining eng kichigi tub son bo'ladi.

I s b o t . $p > 1$ natural sonning 1 ga teng bo'lmagan eng kichik bo'luvchisi q bo'lsin. Uni murakkab son deb faraz qilaylik. U holda murakkab sonning ta'rifiga ko'ra, q soni $1 < q_1 < q$ shartga bo'ysunuvchi q_1 bo'luvchiga ega bo'ladi va q_1 soni p ning ham bo'luvchisi bo'ladi. Bunday bo'lishi esa mumkin emas. Demak, q — tub son.

2- x o s s a. Murakkab p sonining 1 dan katta eng kichik bo'luvchisi \sqrt{p} dan katta bo'lmagan tub sonidir.

I s b o t . p — murakkab son, q esa uning 1 dan farqli eng kichik bo'luvchisi bo'lsin. U holda $p = q \cdot q_1$ (bunda q_1 bo'linma) va $q_1 \geq q$ bo'ladigan q_1 natural son mavjud bo'ladi. Bu munosabatlardan $p = q \cdot q_1 \geq q \cdot q$ yoki $\sqrt{p} \geq q$ ni olamiz. 1- xossaga ko'ra q soni tub sonidir.

3- x o s s a (Yevklid teoremasi). Tub sonlar cheksiz ko'pdir.

I s b o t . Barcha tub sonlar n ta va ular q_1, q_2, \dots, q_n sonlaridan iborat bo'lsin deb faraz qilaylik. U holda $b = q_1 \cdot q_2 \cdot \dots \cdot q_n + 1$ soni murakkab son bo'ladi, chunki q_1, q_2, \dots, q_n sonlardan boshqa tub son yo'q (farazga ko'ra). b ning 1 ga teng bo'lmagan eng kichik bo'luvchisi q bo'lsin. 1- xossaga ko'ra, q tub son va q_1, q_2, \dots, q_n sonlarining birortasidan iborat. b va $q_1 \cdot q_2 \cdot \dots \cdot q_n$ sonlarining har biri q ga bo'linganligi uchun 1 soni ham q ga bo'linadi. Bundan, $q = 1$ ekanligi kelib chiqadi. Bu esa $q \neq 1$ ekanligiga zid. Farazimiz noto'g'ri. Demak, tub sonlar cheksiz ko'p.

Biror n sonidan katta bo'lmagan tub sonlar jadvalini tuzishda *Eratosfen g'alviri* deb ataladigan oddiy usuldan foydalanadilar. Uning mohiyati bilan tanishamiz. Ushbu:

$$1, 2, 3, \dots, n \quad (1)$$

sonlarini olaylik.

(1) ning 1 dan katta birinchi soni 2; u faqat 1 ga va o'ziga bo'linadi, demak, 2 tub son. (1) da 2 ni qoldirib, uning karralisi bo'lgan hamma murakkab sonlarni o'chiramiz; 2 dan keyin turuvchi o'chirilmagan son 3; u 2 ga bo'linmaydi, demak, 3 faqat 1 ga va o'ziga bo'linadi, shuning uchun u tub son. (1) da 3 ni qoldirib, unga karrali bo'lgan hamma sonlarni o'chiramiz; 3 dan keyin turuvchi o'chirilmagan birinchi son 5 dir; u na 2 ga va na 3 ga bo'linadi. Demak, 5 faqat 1 ga va o'ziga bo'linadi, shuning uchun u tub son bo'ladi va h.k.

Agar p tub son bo'lib, p dan kichik tub sonlarga bo'linadigan barcha sonlar yuqoridagi usul bilan o'chirilgan bo'lsa, p^2 dan kichik barcha o'chirilmay qolgan sonlar tub son bo'ladi.

Haqiqatan, bunda p^2 dan kichik har bir murakkab a son, o'zining eng kichik tub bo'luvchisining karralisi bo'lgani uchun o'chirilgan bo'ladi. Shunday qilib:

a) tub son p ga bo'linadigan sonlarni o'chirishni p^2 dan boshlash kerak;

b) n dan katta bo'lmagan tub sonlar jadvalini tuzish, \sqrt{n} dan katta bo'lmagan tub sonlarga bo'linuvchilarini o'chirib bo'lingandan keyin tugallanadi.

1- misol. 827 sonining eng kichik tub bo'luvchisini toping.

Yechish. $\sqrt{827}$ dan kichik bo'lgan tub sonlar 2, 3, 5, 7, 11, 13, 17, 19, 23 ekanligini aniqlab, 827 ni shu sonlarga bo'lib chiqamiz. 827 u sonlarning hech qaysisiga bo'linmaydi, bundan 827 ning tub son ekanligi kelib chiqadi.

2- misol. 15 va 50 sonlari orasida joylashgan tub sonlarni aniqlang.

Yechish. 15, 16, 17, 18, 19, 20, 21, 22, 23, 24, 25, 26, 27, 28, 29, 30, 31, 32, 33, 34, 35, 36, 37, 38, 39, 40, 41, 42, 43, 44, 45, 46, 47, 48, 49, 50 sonlarni olib, 2, 3, 5, 7 ga karrali sonlarning tagiga chizamiz. 17, 19, 23, 29, 31, 37, 41, 47 sonlari izlangan tub sonlardir.

Natural sonlar qatorida tub sonlar turlicha taqsimlangan. Ba'zan qo'shni tub sonlar bir-biridan 2 gagina farq qiladi, masalan, 11 va 13, 101 va 103 va hokazo. Bu sonlar *egizak tub sonlar* deyiladi. Egizak tub sonlar to'plamining chekli yoki cheksizligi hozirgacha noma'lum.

Hisoblash mashinalari yordami bilan juda katta tub sonlar topilgan. Masalan, 25000 xonali $2^{86243} - 1$ son tub sonidir.

Tub sonlar haqidagi ko'p ma'lumotlar juda katta sonlar uchun tekshirilgan, lekin isbotlangan emas. Masalan, istalgan juft sonni ikki tub sonning ayirmasi (masalan, $14 = 127 - 113$, $20 = 907 - 887$ va hokazo) ko'rinishida yozish mumkinmi yoki yo'qmi, buni biz bilmaymiz. Har qanday juft son uchun bunday tasvirlanishlar cheksiz ko'p bo'ladi, deyilgan taxminlar ham bor.

1- teorema (arifmetikaning asosiy teoremasi). *Har qanday murakkab son tub sonlar ko'paytmasiga yoyiladi va agar ko'paytuvchilarning yozilish tartibi nazarga olinmasa, bu yoyilma yagonadir.*

Isbot. a_1 — murakkab son, q_1 esa uning eng kichik tub bo'luvchisi bo'lsin. a_1 ni q_1 ga bo'lamiz: $a_1 = q_1 \cdot a_2$ ($a_2 < a_1$).

Agar a_2 tub son bo'lsa, a_1 son tub ko'paytuvchilarga yoyilgan bo'ladi. Aks holda, a_2 ni o'zining eng kichik tub bo'luvchisi q_1 ga bo'lamiz:

$$a_2 = q_2 \cdot a_3 \quad (a_3 < a_2).$$

Agar a_3 tub son bo'lsa, $a_1 = q_1 \cdot q_2 \cdot a_3$ bo'ladi. q_1, q_2, a_3 sonlari tub sonlar bo'lgani uchun, a_1 soni tub ko'paytuvchilarga yoyilgan bo'ladi. Agar a_3 murakkab son bo'lsa, yuqoridagi jarayon davom ettiriladi.

$a_1 > a_2 > a_3 > \dots$ ekanligidan ko'rinadiki, bir necha qadamdan so'ng albatta a_n tub soni hosil bo'ladi va a_1 soni $a_1 = q_1 \cdot q_2 \cdot \dots \cdot a_n$ shaklni oladi. Demak, har qanday natural son tub ko'paytuvchilarga yoyiladi.

a soni ikki xil ko'rinishdagi tub ko'paytuvchilar yoyilmasiga ega bo'ladi, deb faraz qilaylik:

$$a = p_1 \cdot p_2 \cdot \dots \cdot p_k, \quad (2)$$

$$a = q_1 \cdot q_2 \cdot \dots \cdot q_n. \quad (3)$$

U holda

$$q_1 \cdot q_2 \cdot \dots \cdot q_n = p_1 \cdot p_2 \cdot \dots \cdot p_k. \quad (4)$$

(4) tenglikning ikki tomonida hech bo'lmaganda bittadan tub son topiladiki, u sonlar bir-biriga teng bo'ladi. $p_1 = q_1$ deb faraz qilaylik. Tenglikning ikkala tomonini $p_1 = q_1$ ga qisqartirsak $q_2 \cdot \dots \cdot q_n = p_2 \cdot \dots \cdot p_k$ bo'ladi. Bu tenglik ustida ham yuqoridagidak mulohaza yuritsak, $q_3 \cdot \dots \cdot q_n = p_3 \cdot \dots \cdot p_k$ bo'ladi va hokazo. Bu jarayonni davom ettirsak, $n - 1$ qadamdan so'ng $1 = p_{n+1} \cdot \dots \cdot p_k$ tenglikni olamiz. Bundan $p_{n+1} = 1, \dots, p_k = 1$ ekanligi kelib chiqadi. Demak, yoyilma yagona ekan.

a sonini tub ko'paytuvchilarga yoyishda ba'zi ko'paytuvchilar takrorlanishi mumkin. q_1, q_2, \dots, q_n ko'paytuvchilarning takrorlanishlarini mos ravishda $\alpha, \beta, \dots, \gamma$ orqali belgilasak, $a = q_1^\alpha \cdot q_2^\beta \cdot \dots \cdot q_n^\gamma$ hosil bo'ladi. Bu a sonining *kanonik yoyilmasidir*. Masalan,

$$105840 = 2^4 \cdot 3^3 \cdot 5 \cdot 7^2.$$

Natural sonlarning kanonik yoyilmasidan foydalanib, uning bo'luvchilarini va bo'luvchilar sonini topish mumkin.

2- teorema. *a* natural sonining kanonik yoyilmasi $a = p_1^{\alpha_1} \cdot p_2^{\alpha_2} \cdot \dots \cdot p_n^{\alpha_n}$ bo'lsin. U holda *a* ning har qanday bo'luvchisi $d = p_1^{\beta_1} \cdot p_2^{\beta_2} \cdot \dots \cdot p_n^{\beta_n}$ ko'rinishda bo'ladi, bunda $0 \leq \beta_k \leq \alpha_k$ ($k = \overline{1, n}$).

Isbot. *a* soni *d* ga bo'linsin. $a = dq$. U holda *a* ning hamma tub bo'luvchilari mavjud va ularning darajalari *d* ning kanonik yoyilmasidagi darajalaridan kichik bo'lmaydi. Shunga ko'ra, *d* bo'luvchi $d = p_1^{\beta_1} \cdot p_2^{\beta_2} \cdot \dots \cdot p_n^{\beta_n}$ yoyilmaga ega va *a* ning *d* ga bo'linishi ayon.

Misol tariqasida 48 ning bo'luvchilarini topaylik. $48 = 2^4 \cdot 3$ bo'lganligidan, uning bo'luvchilari quyidagicha topiladi: $2^0 \cdot 3^0, 2^1 \cdot 3^0, 2^2 \cdot 3^0, 2^3 \cdot 3^0, 2^4 \cdot 3^0, 2^0 \cdot 3^1, 2^2 \cdot 3^1, 2^3 \cdot 3^1, 2^4 \cdot 3^1, 2^1 \cdot 3^1$.

a natural sonining natural bo'luvchilari soni $\tau(a)$ bilan belgilanadi.

3- teorema. Agar *a* natural sonining kanonik yoyilmasi $a = p_1^{\alpha_1} \cdot p_2^{\alpha_2} \cdot \dots \cdot p_n^{\alpha_n}$ bo'lsa, $\tau(a) = (\alpha_1 + 1)(\alpha_2 + 1) \dots (\alpha_n + 1)$ tenglik o'rinli bo'ladi.

Isbot. 2- teoremaga asosan $a = p_1^{\alpha_1} \cdot p_2^{\alpha_2} \cdot \dots \cdot p_n^{\alpha_n}$ sonining har bir bo'luvchisi $p_1^{\beta_1} \cdot p_2^{\beta_2} \cdot \dots \cdot p_n^{\beta_n}$ ko'rinishda bo'ladi. β_1 ifoda $0; 1; 2; \dots; \alpha_1$ qiymatlarni qabul qiladi. Shu kabi β_2 ifoda $\alpha_2 + 1$ ta qiymatni qabul qiladi va hokazo. $\beta_1, \beta_2, \dots, \beta_n$ qiymatlarning ixtiyoriy kombinatsiyasi *a* sonining biror bo'luvchisini aniqlaydi.

$\beta_1, \beta_2, \dots, \beta_n$ qiymatlarning mumkin bo'lgan kombinatsiyalarining va demak, *a* ning natural bo'luvchilarining soni $(\alpha_1 + 1)(\alpha_2 + 1) \dots (\alpha_n + 1)$ ga teng.

Ba'zi hollarda natural son bo'luvchilarining yig'indisini topishga to'g'ri keladi. Bunday hollarda, natural son bo'luvchilarining yig'indisi

$\delta(a)$ ni hisoblash formulasi $\delta(a) = \frac{p_1^{\alpha_1+1}-1}{p_1-1} \cdot \frac{p_2^{\alpha_2+1}-1}{p_2-1} \dots \frac{p_k^{\alpha_k+1}-1}{p_k-1}$

dan foydalanish mumkin.

3- misol. 20 ning bo'luvchilari sonini va bo'luvchilari yig'indisini toping.

Yechish. $20 = 2^2 \cdot 5^1$ bo'lgani sababli, 20 ning bo'luvchilari soni $\tau(20) = (2 + 1)(1 + 1) = 6$, bo'luvchilarining yig'indisi esa

$$\delta(20) = \frac{2^{2+1}-1}{2-1} \cdot \frac{5^{1+1}-1}{5-1} = 7 \cdot 6 = 42$$

bo'ladi.



Mashqlar

$k \in \mathbb{N}$ soniga bo'linadigan barcha natural sonlar to'plamini A_k bilan belgilaymiz [2.1 – 2.7].

2.1. Tasdiq to'g'rimi:

- | | | |
|---------------------|-----------------------|-------------------------------|
| a) $2 \in A_3$; | f) $25 \notin A_5$; | j) $15\ 342\ 749 \in A_9$; |
| b) $2 \in A_4$; | g) $36 \in A_2$; | k) $15\ 342\ 724 \in A_4$; |
| d) $6 \notin A_5$; | h) $41 \in A_3$; | l) $15\ 342\ 824 \in A_8$; |
| e) $11 \in A_9$; | i) $422 \notin A_9$; | m) $4\ 343\ 242 \in A_{11}$? |

2.2. $11 \cdot 12 \cdot 13 \cdot 14 \cdot 15 \cdot 16$ soni $A_2, A_3, A_4, A_5, A_6, A_7, A_8, A_9, A_{10}, A_{11}$ to'plamlariga qaysilariga tegishli?

2.3. $1 \cdot 2 \cdot 3 \cdot 4 \cdot \dots \cdot 8 \cdot 9 \notin A_k$ bo'lsa, $k = 2431$ bo'lishi mumkinmi?

$k \in \{15; 18\}$ bo'lishi mumkinmi?

2.4. $3 \cdot 5 \cdot 7 \in A_k$ bo'lsa, k ning qabul qilishi mumkin bo'lgan barcha qiymatlarini toping.

2.5. $A_2 \cap A_6, A_2 \cap A_3, A_3 \cap A_5$ larni toping.

2.6. $A_2 \cup A_3 = A_6$ tenglik to'g'rimi?

2.7. $a \in A_3, a \in A_4$ bo'lsa, $a + b \notin A_7$ bo'lishi mumkinmi?

2.8. Sonlarni tub ko'paytuvchilarga ajrating:

10; 100; 1 000; 10 000; 100 000; 1 000 000. Qanday xulosaga kelish mumkin?

2.9. Sonlarni tub ko'paytuvchilarga ajrating:

250; 300; 340; 3 700; 48 950; 4 725 000.

2.10. Sonlarni kanonik shaklda yozing:

- | | | | |
|--------|---------|-----------|------------|
| a) 36; | f) 125; | j) 946; | n) 13 860; |
| b) 72; | g) 36; | k) 1 001; | o) 2 431; |
| d) 81; | h) 512; | l) 3 125; | p) 6 783; |
| e) 96; | i) 680; | m) 4 500; | q) 36 363. |

2.11. Sonlarni kanonik shaklda yozing:

- a) $2 \cdot 3^2 \cdot 2^4 \cdot 6^2$; f) $18 \cdot 18 \cdot 15 \cdot 5$; j) $15^2 \cdot 17 \cdot 21^3$;
b) $4 \cdot 5 \cdot 7 \cdot 9$; g) $17 \cdot 19 \cdot 25$; k) $27^3 \cdot 11 \cdot 3^4$;
d) $3 \cdot 5 \cdot 7 \cdot 11$; h) $3^4 \cdot 4^3 \cdot 53$; l) $33 \cdot 34 \cdot 43^2$;
e) $13 \cdot 13 \cdot 27$; i) $31^2 \cdot 33 \cdot 37^2 \cdot 39$; m) $117 \cdot 118 \cdot 119^2$.

2.12. Quyidagilarni toping:

- a) $\tau(81)$, $\delta(81)$; f) $\tau(2^3 \cdot 6 \cdot 7)$;
b) $\tau(91)$, $\delta(91)$; g) $\tau(2^3 \cdot 3^2 \cdot 5)$;
d) $\tau(400)$; h) $\tau(11 \cdot 13 \cdot 17)$;
e) $\tau(680)$; i) $\tau(19^2 \cdot 23 \cdot 29)$.

2.13. Quyidagilarni toping:

- a) $\tau(512)$, $\delta(512)$; f) $\tau(4^2 \cdot 6 \cdot 15)$;
b) $\tau(1\ 001)$, $\delta(1\ 001)$; g) $\tau(13 \cdot 100 \cdot 55)$;
d) $\tau(13\ 860)$, $\delta(13\ 860)$; h) $\tau(121 \cdot 11^2)$;
e) $\tau(13\ 800)$, $\delta(13\ 800)$; i) $\tau(144 \cdot 11^3)$.

2. Eng katta umumiy bo'luvchi. Eng kichik umumiy karrali. Yevklid algoritmi. $a, b \in N$ sonlarning har biri bo'linadigan son shu sonlarning *umumiy bo'luvchisi* deyiladi. Masalan, $a = 12$; $b = 14$ bo'lsin. Bu sonlarning umumiy bo'luvchilari 1; 2 bo'ladi.

$a, b \in N$ sonlar umumiy bo'luvchilarining eng kattasi shu sonlarning *eng katta umumiy bo'luvchisi* deyiladi va $B(a; b)$ orqali belgilanadi.

Masalan, $B(12; 14) = 2$.

Agar $B(a; b) = 1$ bo'lsa, a va b sonlar *o'zaro tub sonlar* deyiladi.

Masalan, $B(16; 21) = 1$ bo'lgani uchun 16 va 21 o'zaro tub sonlardir.

$a, b \in N$ sonlarning *umumiy karralisi* deb, a ga ham, b ga ham bo'linuvchi natural songa aytiladi.

a va b sonlarning umumiy karralisi ichida eng kichigi mavjud bo'lib, u a va b sonlarining *eng kichik umumiy karralisi* deyiladi va $K(a; b)$ orqali belgilanadi.

Masalan, $K(6; 8) = 24$.

Natural sonlarning kanonik yoyilmalari bir nechta sonning eng katta umumiy bo'luvchi va eng kichik umumiy karralilarini topishda ham qo'llaniladi.

a , b va c sonlari berilgan bo'lib,

$$a = p_1^{\alpha_1} \cdot p_2^{\alpha_2} \cdot \dots \cdot p_n^{\alpha_n}, \quad b = p_1^{\beta_1} \cdot p_2^{\beta_2} \cdot \dots \cdot p_n^{\beta_n}$$

$$\text{va } c = p_1^{\gamma_1} \cdot p_2^{\gamma_2} \cdot \dots \cdot p_n^{\gamma_n}$$

bo'lsin. t_k deb α_k , β_k va γ_k larning eng kichik qiymatini, s_k deb α_k , β_k va γ_k larning eng katta qiymatini olaylik. U holda:

$$B(a, b, c) = p_1^{t_1} \cdot p_2^{t_2} \cdot \dots \cdot p_n^{t_n}; \quad K(a, b, c) = p_1^{s_1} \cdot p_2^{s_2} \cdot \dots \cdot p_n^{s_n}$$

bo'ladi.

Misol. $126 = 2 \cdot 3^2 \cdot 7$, $540 = 2^2 \cdot 3^3 \cdot 5$ va $630 = 2 \cdot 3^2 \cdot 5 \cdot 7$ bo'lgani uchun

$$B(126; 540; 630) = 2 \cdot 3^2 = 18,$$

$$K(126; 540; 630) = 2^2 \cdot 3^3 \cdot 5 \cdot 7 = 3780 \text{ larga ega bo'lamiz.}$$

$a, b \in N$ va $a \geq b$ bo'lsin. U holda a va b sonlari uchun $a = bq + r$ ($0 \leq r < b$) tenglik o'rinli bo'ladigan $q \in N$, $r \in N$ sonlari mavjud va q, r sonlari bir qiymatli aniqlanadi.

1-teorema. *Agar $a \geq b$ bo'lib, $a = bq + r$ ($0 \leq r < b$) bo'lsa, a va b sonlarining barcha umumiy bo'luvchilari b va r sonlarining ham umumiy bo'luvchilari bo'ladi va, aksincha, $a = bq + r$ ($0 \leq r < b$) bo'lsa, b va r sonlarining barcha umumiy bo'luvchilari a va b sonlarining ham umumiy bo'luvchilari bo'ladi.*

Isbot. $a = bq + r$ bo'lib, c soni a va b sonlarining biror umumiy bo'luvchisi bo'lsin.

$r = a - bq$ bo'lganligidan r ham c ga bo'linadi, ya'ni c soni b va r sonlarining umumiy bo'luvchisi. Aksincha, c' soni b va r sonlarining umumiy bo'luvchisi bo'lsin, unda $a = bq + r$ ham c' ga bo'linadi, ya'ni c' soni a va b sonlarining umumiy bo'luvchisi. Shunday qilib, a va b ning umumiy bo'luvchisi bir xil ekan.

Natija: $a = bq + r$ bo'lsa, $B(a; b) = B(b; r)$ bo'ladi.

Isbotlangan teorema va uning natijasi asosida, $B(a; b)$ ni topishning Yevklid algoritmi deb ataluvchi quyidagi usuliga ega bo'lamiz.

$a, b \in N$, $a > b$ bo'lsin. a ni b ga qoldiqli bo'lamiz:

$$a = bq_1 + r_2, \quad 0 \leq r_2 < b.$$

Agar $r_2 = 0$ bo'lsa, $B(a; b) = b$ bo'ladi. $r_2 \neq 0$ bo'lsa, natijaga ko'ra $B(a; b) = B(b; r_2)$ (1) bo'ladi.

b ni r_2 ga qoldiqli bo'lamiz:

$$b = r_2 q_2 + r_3, \quad 0 \leq r_3 < r_2.$$

Agar $r_3 = 0$ bo'lsa, $B(a; b) = B(b; r_2) = r_2$ bo'ladi. $r_3 \neq 0$ bo'lsa, natijaga ko'ra $B(a; b) = B(b; r_2) = B(r_2; r_3)$ (2) bo'ladi.

r_2 ni r_3 ga qoldiqli bo'lamiz:

$$r_2 = r_3 q_3 + r_4, \quad 0 \leq r_4 < r_3.$$

Agar $r_4 = 0$ bo'lsa, $B(a; b) = B(b; r_2) = B(r_2; r_3) = r_3$ bo'ladi. $r_4 \neq 0$ bo'lsa, natijaga ko'ra $B(a; b) = B(b; r_2) = B(r_2; r_3) = B(r_3; r_4)$ bo'ladi va yuqoridagi jarayonni davom ettiramiz. Bu jarayonda qoldiqlar natural sonlar bo'lib, kichiklashib boradi ($r_2 > r_3 > r_4 > \dots$). Shu sababli, biror qadamdan so'ng qoldiq 0 ga teng bo'ladi, ya'ni biror n natural son uchun $r_{n+1} = 0$ bo'ladi va $r_{n-1} = r_n \cdot q_n + 0 = r_n \cdot q_n$ tenglik bajariladi. Bu holda $B(r_{n-1}; r_n)$ va $r_n \neq 0$, $r_{n-1} \neq 0$, $r_{n-2} \neq 0$, ..., $r_2 \neq 0$ munosabatlarga ega bo'lamiz. Yuqoridagi mulohazalardan, $B(a; b) = B(b; r_2) = B(r_2; r_3) = B(r_3; r_4) = \dots = B(r_{n-1}; r_n) = r_n$ bo'lishi kelib chiqadi.

Shunday qilib, $B(a; b)$ ni topish uchun qoldiqli bo'lish jarayoni 0 ga teng qoldiq hosil bo'lguncha davom ettiriladi, 0 dan farqli eng oxirgi qoldiq, a va b sonlarining eng katta umumiy bo'luvchisi bo'ladi.

Misol. $B(1515; 600)$ ni topamiz.

$$\begin{array}{r}
 1515 \overline{)600} \\
 \underline{-1200} \quad 2 \\
 600 \overline{)315} = r_2 \\
 \underline{-315} \quad 1 \\
 315 \overline{)285} = r_3 \\
 \underline{-285} \quad 1 \\
 285 \overline{)30} = r_4 \\
 \underline{-270} \quad 9 \\
 30 \overline{)15} = r_5 \\
 \underline{-30} \quad 2 \\
 0 = r_6
 \end{array}$$

Demak, $B(1515; 600) = 15$.

Ikkitadan ortiq a_1, a_2, \dots, a_n sonlarining eng katta umumiy bo'luvchisi va eng kichik umumiy karralisini topish quyidagicha amalga oshiriladi. $B(a_1, a_2) = d_2; B(d_2, a_3) = d_3, \dots, B(d_{n-1}, a_n) = d_n$. Bu yerda $d_n = B(a_1, a_2, \dots, a_n)$ bo'ladi. Xuddi shunday $K(a_1, a_2) = k_2, K(k_2, a_3) = k_3, \dots, K(k_{n-1}, a_n) = k_n$ bo'lib, $K(a_1, a_2, \dots, a_n) = k_n$ bo'ladi.

Endi $B(a; b)$ va $K(a; b)$ orasidagi bog'lanishni ko'ramiz.

2- teorema. $B(a; b) \cdot K(a; b) = a \cdot b$.

Isbot. M soni a va b sonlarining biror umumiy karralisi bo'lsin. U holda

$$M = ak \quad (k \in N) \quad (1)$$

bo'ladi. Bundan ak soni b ga bo'linadi, degan xulosaga kelamiz.

$B(a; b) = d$ va $a = a_1d; b = b_1d$ bo'lsa, $B(a_1; b_1) = 1$ bo'ladi.

ak soni b ga bo'linganligidan a_1kd soni ham b_1d soniga bo'linishi, bundan esa a_1k ning b_1 ga bo'linishi kelib chiqadi. Ammo $B(a_1; b_1) = 1$ bo'lgani uchun k soni b_1 ga bo'linadi.

Demak,

$$k = b_1t = \frac{b}{d} \cdot t, \quad t \in N. \quad (2)$$

(2) ni (1) ga qo'ysak,

$$M = \frac{ab}{d} \cdot t \quad (3)$$

hosil bo'ladi. (3) ko'rinishdagi har bir son a va b sonlarining umumiy karralisi bo'ladi.

$K(a; b)$ ni topish uchun $t = 1$ deb olish yetarli.

Demak, $K(a; b) = \frac{a \cdot b}{d}$ yoki $a \cdot b = K(a; b) \cdot B(a; b)$.



Mashqlar

2.14. Sonning bo'luvchilarini toping:

- a) 209; b) 143; d) 2 431; e) 2 717.

2.15. Sonlarning umumiy bo'luvchilarini toping:

- a) 209 va 143; d) 143 va 2 717;
b) 209 va 2 431; e) 2 431 va 2 717.

2.16. Sonlarning eng katta umumiy bo'luvchisini toping:

- a) 40 va 45; h) 84, 63 va 42;
b) 130 va 160; i) 72, 48 va 36;
d) 121 va 143; j) 63, 130, 143 va 1 001;
e) 31 va 93; k) 74, 60, 84 va 480;
f) 50, 75 va 100; l) 750, 800, 865 va 1 431;
g) 74, 45 va 60; m) 143, 209, 1 431 va 2 717.

2.17. Quyidagi sonlar o'zaro tubmi:

- a) 15 va 95; h) 14, 16 va 19;
b) 144 va 169; i) 63, 130 va 800;
d) 143 va 144; j) 169 va 1 443;
e) 250 va 131; k) 111 va 121;
f) 121 va 143; l) $n, n + 1$ va $n + 2$ ($n \in N$);
g) 11, 12 va 25; m) $n, n + 2$ va $n + 4$ ($n \in N$)?

2.18. Sonlarning eng kichik umumiy karralisini toping.

- a) 84, 42 va 21; h) 11, 12 va 13;
b) 70, 80 va 90; i) 50, 125 va 175;
d) 17, 51 va 289; j) 48, 92 va 75;
e) 10, 21 va 3 600; k) 100, 150 va 250;
f) 18, 19 va 24; l) 80, 240 va 360;
g) 33, 36 va 48; m) 34, 51 va 65.

2.19. Sonlarning eng katta umumiy bo'luvchisini va eng kichik umumiy karralisini toping (natijani kanonik ko'rinishda yozing):

- a) $2^3, 3^2$ va 15; f) $7^2 \cdot 3; 46$ va 15;
b) $2^3, 3^4$ va 7; g) $3^2 \cdot 4; 3 \cdot 6$ va $7 \cdot 9$;
d) 8, 13^2 va 5^2 ; h) $3^4, 11^2$ va 13^3 ;
e) $12^2, 15$ va 1; i) $11^4, 13^5$ va 100^4 .

2.20. Sonlarning umumiy bo'luvchisi nechta:

- a) 18 va 54; f) 63 va 72;
b) 42 va 56; g) 120 va 96;
d) 96 va 92; h) 102 va 170;
e) 84 va 120; i) 26, 65 va 130;

j) 150 va 180;

l) 54, 90 va 162;

k) 12, 18 va 30;

m) 40, 60 va 100?

1.21. Tenglamalar sistemasini yeching:

$$\text{a) } \begin{cases} B(x, y) = 45, \\ \frac{x}{y} = \frac{11}{7}; \end{cases}$$

$$\text{b) } \begin{cases} xy = 20, \\ K(x, y) = 10. \end{cases}$$

1.22. Hisoblang:

a) $\tau(\tau(B(K(250; 500); 100)));$

b) $B(\tau(100); \tau(B(25; 5)) + \tau(K(10; 35)));$

d) $K(K(\tau(144); 51); 18) - \tau(42);$

e) $\tau(18 \cdot 91 + 15(B(10; 21))) \cdot \tau(142).$

1.23. Sonlarning eng katta umumiy bo'luvchisini toping:

a) 8 104 va 5 602;

h) 5 400 va 8 400;

b) 5 555 va 11 110;

i) 78 999 va 80 000;

d) 980 va 100;

j) 795 va 2 585;

e) 5345 va 4 856;

k) 42 628 va 33 124;

f) 187 va 180;

l) 71 004 va 154 452;

g) 2 165 va 3 556;

m) 1 000 va 999.

1.24. Quyidagi sonlar o'zaro tubmi:

a) 60 va 72;

d) 55 va 71;

b) 732 va 648;

e) 111 va 11?

1.25. $B(a; b) \cdot K(a; b) = a \cdot b$ ($a \in N, b \in N$) tenglikdan foydalanib, quyidagi sonlarning eng kichik umumiy karralisini toping:

a) 821 va 934;

f) 28 va 947;

j) 75 va 1 853;

b) 743 va 907;

g) 56 va 953;

k) 23 va 1 785;

d) 109 va 1 005;

h) 419 va 854;

l) 113 va 9 881;

e) 827 va 953;

i) 887 va 6 663;

m) 875 va 1 346.

1.26. Sonlarning o'zaro tub ekanligini isbotlang:

a) 911 va 130 177;

b) 811 va 10 403.

1.27. Hisoblang: $\tau(B(911; 659; 647 + 367)).$

3. Sonlarning bo'linish belgilari. Matematikada sonlarning bo'linish belgilari juda muhim ahamiyatga ega. Bu belgilar asosida

sonlarning bo'luvchilarini, bo'linuvchilarini topish, ularning xossalari o'rganish mumkin.

$$a = \overline{a_n a_{n-1} \dots a_1 a_0} = a_n 10^n + a_{n-1} 10^{n-1} + \dots + a_1 10 + a_0 \quad (1)$$

natural sonning berilgan b natural songa bo'linish-bo'linmasligini aniqlash kerak bo'lsin. 10 ning darajalarini b ga qoldiqli bo'lamiz:

$$10 = bq_1 + r_1; 10^2 = bq_2 + r_2; \dots; 10^n = bq_n + r_n.$$

Bu tengliklarni (1) ga qo'yib, shakl almashtirsak,

$$a = Ab + B \quad (2)$$

hosil bo'ladi. Bu yerda

$$A = a_n q_n + a_{n-1} q_{n-1} + \dots + a_1 q_1, \quad B = a_0 + a_1 r_1 + \dots + a_n r_n.$$

Hosil bo'lgan (2) tenglikdan ko'rinib turibdiki, B soni b ga bo'linganda va faqat shu holda a soni b ga bo'linadi.

Bu xulosadan sonlarning bo'linish belgilarini topishda foydalaniladi.

1. 2 ga bo'linish belgisi. 10^k ($k = 1, 2, \dots, n$) ni $b = 2$ ga bo'lishdan chiqadigan qoldiqlar nolga teng. Shuning uchun $B = a_0$ bo'ladi. Bundan a sonning oxirgi raqami 2 ga qoldiqsiz bo'linsa, bu son 2 ga qoldiqsiz bo'linadi, degan xulosaga kelamiz.

2. 3 va 9 ga bo'linish belgisi. 10 ning darajalarini $10^n = (9 + 1)^n = 9A_n + 1$ ko'rinishda ifodalasak (bu yerda $A_n \in \mathbb{N}$), 10^n darajalarni $b = 9$ (yoki $b = 3$) ga bo'lishdan chiqadigan qoldiqlar 1 ga tengligi kelib chiqadi. Shuning uchun $B = a_0 + a_1 + \dots + a_n$ hosil bo'ladi. Bu yerdan ushbu qoida kelib chiqadi: *agar berilgan a sonning raqamlari yig'indisi 9 ga (3 ga) qoldiqsiz bo'linsa, u holda bu son 9 ga (3 ga) qoldiqsiz bo'linadi.*

3. 5 ga bo'linish belgisi. 10^k ($k = 1, 2, \dots, n$) darajalar $b = 5$ ga qoldiqsiz bo'linadi: $r_1 = r_2 = \dots = r_n = 0$. $B = a_0$ bo'lgani uchun ushbu qoida kelib chiqadi: *oxirgi raqami 5 ga qoldiqsiz bo'linadigan sonlar va faqat shunday sonlar 5 ga qoldiqsiz bo'linadi.*

4. 4 va 25 ga bo'linish belgilari. $b = 4$ bo'lganda $10 = 2b + 2$, $10^2 = 25b + 0$, $10^3 = 250b + 0$, ..., $r_1 = 2$, $r_2 = r_3 = \dots = r_n = 0$ bo'lib, $B = a_0 + 2a_1$ bo'ladi, ya'ni sonning 4 ga bo'linishi uchun, uning birlik raqami bilan o'nlik raqami ikkilanganining yig'indisi 4 ga bo'linishi zarur va yetarlidir. $B = a_0 + 2a_1$ ifodani bunday yozamiz:

$$B_1 = a_0 + 2a_1 + 8a_1 = B + 8a_1 = 10a_1 + a_0 = \overline{a_1a_0}.$$

$B = a_0 + 2a_1 = (a_0 + 10a_1) - 8a_1 = \overline{a_1a_0} - 8a_1$ yoki $B + 8a_1 = \overline{a_1a_0}$ bo'lgani uchun B son $\overline{a_1a_0}$ soni 4 ga bo'linganda va faqat shu holdagina 4 ga qoldiqsiz bo'linadi. Bundan, *oxirgi ikkita raqamidan tuzilgan son 4 ga bo'linadigan sonlar va faqat shunday sonlar 4 ga bo'linishi kelib chiqadi.*

Masalan, 14 024 sonining oxirgi 2 va 4 raqamlaridan tuzilgan 24 soni 4 ga bo'linadi, demak, 14 024 soni ham 4 ga bo'linadi.

Xuddi shunday *oxirgi ikki raqamidan tuzilgan son 25 ga bo'linadigan sonlar va faqat shunday sonlar 25 ga bo'linadi.*

Masalan, 1 350 sonida oxirgi ikki raqamidan iborat son 50, bu 25 ga qoldiqsiz bo'linadi. Demak, 1 350 ham 25 ga qoldiqsiz bo'linadi. 2^2 va 5^2 uchun olingan xulosani 2^m , 5^m ($m \in \mathbb{N}$) sonlari uchun ham umumlashtirish mumkin.

Agar berilgan sonning oxirgi m ta raqamidan tuzilgan son 2^m ga (5^m ga) qoldiqsiz bo'linsa, berilgan son ham 2^m ga (5^m ga) qoldiqsiz bo'linadi.

5. 7 ga bo'linish belgisi. Bizda $b = 7$ va

$$10 = 7 + 3, \quad r_1 = 3;$$

$$10^2 = 7 \cdot 14 + 2, \quad r_2 = 2;$$

$$10^3 = 7 \cdot 142 + 6, \quad r_3 = 6;$$

$$10^4 = 7 \cdot 1428 + 4, \quad r_4 = 4;$$

$$10^5 = 7 \cdot 14285 + 5, \quad r_5 = 5;$$

$$10^6 = 7 \cdot 142857 + 1, \quad r_6 = 1.$$

10^7 da $r_7 = 3 = r_1$ qoldiqlar qaytadan takrorlanyapti. Topilgan natijalarni (1) ga qo'ysak, u holda $a = A \cdot 7 + B$ da $B = a_0 + 3a_1 + 2a_2 + 6a_3 + 4a_4 + 5a_5 + a_6 + 3a_7 + a_8 + \dots$ yoki koefitsiyentlarni 7 ga nisbatan yozsak:

$$B = a_0 + 3a_1 + 2a_2 + (7a_3 - a_3) + (7a_4 - 3a_4) + (7a_5 - 2a_5) + \dots =$$

$$= 7(a_3 + a_4 + a_5 + a_9 + a_{10} + a_{11} + \dots) +$$

$$+ (a_0 + 3a_1 + 2a_2 + a_6 + 3a_7 + 2a_8 + \dots) -$$

$$- (a_3 + 3a_4 + 2a_5 + a_9 + 3a_{10} + 2a_{11} + \dots)$$

ni hosil qilamiz. Oxirgi ifodada $a_0 + 3a_1 + 2a_2 + a_6 + 3a_7 + 2a_8 + \dots = B_2$, $a_3 + 3a_4 + 2a_5 + a_9 + 3a_{10} + 2a_{11} + \dots = B_1$ deb belgilasak, $a = 7 \cdot A + B_2 - B_1$ ga ega bo'lamiz. Shunday qilib, $B_2 - B_1$ ayirma 7 ga qoldiqsiz bo'linsa, berilgan a son ham 7 ga qoldiqsiz bo'linishi kelib chiqadi.

1- misol. 675 056 742 sonining 7 ga bo'linishi yoki bo'linmasligini aniqlang.

Yechish.

742	056	675
231	231	231
14 + 12 + 2 = 28	0 + 15 + 6 = 21	12 + 21 + 5 = 38

$$38 + 28 - 21 = 66 - 21 = 45 \text{ soni } 7 \text{ ga bo'linmaydi.}$$

Demak, berilgan son 7 ga bo'linmaydi.

6. 11 ga bo'linish belgisi. Berilgan a sonda qatnashayotgan 10 ning darajalarini 11 ga bo'lishdagi qoldiq har doim 10 yoki 1 bo'ladi. Demak, *berilgan sonning juft o'ringa turgan raqamlari yig'indisidan toq o'ringa turgan raqamlari yig'indisi ayirilganda hosil bo'ladigan ayirma 11 ga bo'linsa, son 11 ga qoldiqsiz bo'linadi.*

2- misol. 4 788 sonining 11 ga bo'linishini aniqlang.

$(7 + 8) - (4 + 8) = 15 - 12 = 3$ soni 11 ga bo'linmaydi, demak, berilgan son ham 11 ga bo'linmaydi.

3- misol. 3 168 ning 11 ga bo'linishini tekshiring.

$$(1 + 8) - (3 + 6) = 0. \text{ Demak, son } 11 \text{ ga bo'linadi.}$$

Natija. Agar $B(p, q) = 1$ bo'lib, a soni ham p ga, ham q ga bo'linsa, u pq ga bo'linadi.

Masalan, biror son ham 2 ga, ham 3 ga bo'linsa, u 6 ga bo'linadi, 3 ga va 4 ga bo'linadigan sonlar 12 ga ham bo'linadi va hokazo.

Qadimgi Samarqand madrasalarida a sonni biror b (masalan, 9) ga bo'lishdan chiqadigan qoldiq r ni shu sonning *mezoni* (o'lchami) deb ataganlar va undan sonlar ustida amallar to'g'ri

bajarilganini tekshirishda foydalanganlar. Masalan, $378 \cdot 4\,925 = 1\,861\,650$ dagi natija to'g'ri hisoblanganligini tekshiramiz.

Mezonlar (9 ga bo'linish belgisi bo'yicha):

378 uchun: $3 + 7 + 8 = 18$, $1 + 8 = 9$;

4 925 uchun: $4 + 9 + 2 + 5 = 20$, $2 + 0 = 2$.

Mezonlar ko'paytmasi: $9 \cdot 2 = 18$, $1 + 8 = 9$.

1 861 650 uchun: $1 + 8 + 6 + 1 + 6 + 5 + 0 = 27$, $2 + 7 = 9$.

Mezonlar va berilgan sonlar ko'paytmalarining mezonlari teng, ya'ni $9 = 9$. Demak, topilgan ko'paytma to'g'ri.



M a s h q l a r

- 2.28. 1 dan 25 gacha bo'lgan natural sonlar qatoridagi 6 ga bo'linmaydigan natural sonlar to'plamini tuzing.
- 2.29. 1 dan 25 gacha bo'lgan natural sonlar qatoridagi 7 ga bo'linadigan natural sonlar to'plamini tuzing.
- 2.30. 15 121, 117 342, 1 897 524, 2 134 579, 31 445 698 sonlari orasidan 6 ga bo'linadigan natural sonlar to'plamini tuzing.
- 2.31. Ikkita ketma-ket toq sonlarning yig'indisi 4 ga bo'linishini isbotlang.
- 2.32. $\overline{1234xy}$ soni 8 ga va 9 ga bo'linsa, x va y raqamlarni toping.
- 2.33. 13 ga bo'linish belgisini chiqaring.

2- §. Ratsional sonlar

1. Butun sonlar. Oddiy kasrlar. Nol sonini natural sonlar to'plamiga kiritib, butun *manfiymas sonlar to'plami* deb ataladigan yangi sonli to'plam hosil qilamiz va bu kengaytirilgan to'plamni $N_0 = \{0, 1, 2, 3, \dots, n, \dots\}$ orqali belgilaymiz. Katta sonni kichik sondan ayirish mumkin bo'lishi uchun N_0 sonlar to'plamini yangi sonlar kiritish yo'li bilan yanada kengaytirish zarur.

To'g'ri chiziqni olib, unda yo'nalish, 0 boshlang'ich nuqta va masshtab birligini olamiz (7- rasm). Boshlang'ich nuqtaga 0 sonini mos qo'yamiz. Boshlang'ich nuqtadan o'ng tomonda bir, ikki, uch va h.k. masshtab birligi masofada joylashgan nuqtalarga

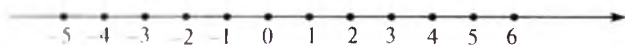

7- rasm.

1, 2, 3, ... natural sonlarni mos qo'yamiz, boshlang'ich nuqtadan chap tomonda bir, ikki, uch va h.k. birlik masofada joylashgan nuqtalarga $-1, -2, -3, \dots$ simvollari bilan belgilanadigan yangi sonlarni mos qo'yamiz.

Bu sonlar *butun manfiy sonlar* deb ataladi. Sonlar belgilangan bu to'g'ri chiziq *son o'qi* deb ataladi. O'qning strelka bilan ko'rsatilgan yo'nalishi *musbat yo'nalish*, bunga qarama-qarshi yo'nalish esa *manfiy yo'nalish* deb ataladi. Natural sonlar son o'qida boshlang'ich nuqtadan musbat yo'nalishda qo'yiladi, shuning uchun ular *musbat butun sonlar* deb ataladi.

Butun manfiymas sonlar to'plami bilan butun manfiy sonlar to'plamining birlashmasi yangi sonli to'plamni hosil qiladi, bu to'plam *butun sonlar to'plami* deb ataladi va Z simvoli bilan belgilanadi:

$$Z = \{ \dots, -4, -3, -2, -1, 0, 1, 2, 3, 4, \dots \}.$$

a va $-a$ sonlar *qarama-qarshi* sonlar deb ataladi. Son o'qida bu sonlarga mos keladigan nuqtalar nolga nisbatan simmetrik joylashadi (8- rasm).

O'lchash natijasi butun sonlarda, o'nli yoki oddiy kasrlarda ifodalanadi. Agar miqdor qarama-qarshi (o'sish-kamayish, yuqoriga-quyiga, foyda-zarar, issiq-sovuq va hokazo) ma'noga ham ega bo'lsa, uning qiymatlari oldiga mos ravishda musbatlik («+») yoki manfiylik («-») ishorasi qo'yiladi: $x = -8, y = 8, t = +5^\circ$.

$\frac{m}{n}$ ifoda oddiy kasr deb ataladi, bunda $m \in Z, n \in N$.

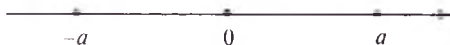

8- rasm.

Agar $\frac{p}{q}$ va $\frac{m}{n}$ kasrlar uchun $pn = mq$ sharti bajarilsa, u holda bu oddiy kasrlar *teng* deyiladi va $\frac{p}{q} = \frac{m}{n}$ ko'rinishida yoziladi. Oddiy kasrlar uchun quyidagi xossalar o'rindir:

1. Har qanday kasr o'z-o'ziga teng: $\frac{a}{b} = \frac{a}{b}$, chunki $ab = ba$.
2. Agar $\frac{a}{b} = \frac{c}{d}$ bo'lsa, u holda $\frac{c}{d} = \frac{a}{b}$ bo'ladi.
3. Agar $\frac{a}{b} = \frac{c}{d}$ bo'lib, $\frac{c}{d} = \frac{l}{n}$ bo'lsa, u holda $\frac{a}{b} = \frac{l}{n}$ bo'ladi.
4. Agar $\frac{p}{q}$ kasrning surat va maxraji $m \neq 0$ songa ko'paytirilsa yoki bo'linsa, uning qiymati o'zgarmaydi, ya'ni $\frac{p}{q} = \frac{p \cdot m}{q \cdot m} \Rightarrow$

$$\Rightarrow p \cdot q \cdot m = q \cdot p \cdot m \quad \text{yoki} \quad \frac{p}{q} = \frac{p \cdot m}{q \cdot m} \quad \text{bo'ladi.}$$

Ko'paytmasi birga teng bo'lgan ikkita sonlar *o'zaro teskari* sonlar deb ataladi. Bular $\frac{m}{n}$ va $\frac{n}{m}$ ko'rinishidagi sonlardir.

Bir necha kasrni umumiy maxrajga keltirish deb, bu kasrlarning qiymatlarini o'zgartirmasdan ularni bir xil maxrajga olib keluvchi almashtirishga aytiladi.

$\frac{a}{b}$ va $\frac{c}{d}$ kasrlarni qo'shish, ayirish, ko'paytirish va bo'lish amallari quyidagi tengliklar bilan aniqlanadi:

$$\frac{a}{b} \pm \frac{c}{d} = \frac{ad \pm bc}{bd}; \quad \frac{a}{b} \cdot \frac{c}{d} = \frac{ac}{bd}; \quad \frac{a}{b} : \frac{c}{d} = \frac{ad}{bc}.$$

Natural son bilan musbat oddiy kasrning yig'indisini «+» ishorasiz yozish qabul qilingan. Masalan,

$$45 + \frac{1}{2} = 45\frac{1}{2}, \quad 58 + \frac{3}{7} = 58\frac{3}{7} \quad \text{va hokazo.}$$



M a s h q l a r

2.34. Amallarni bajaring:

$$\text{a) } \frac{8}{45} + \frac{16}{45}; \quad \text{b) } \frac{17}{48} - \frac{7}{48}; \quad \text{d) } \frac{17}{35} + \frac{18}{35};$$

$$\begin{array}{lll}
 \text{e)} \frac{18}{69} + \frac{59}{69}; & \text{f)} \frac{1112}{150} - \frac{338}{150}; & \text{g)} \frac{17}{18} + \frac{13}{36}; \\
 \text{h)} \frac{32}{15} - \frac{17}{148}; & \text{i)} \frac{15}{17} - \frac{7}{18}; & \text{j)} \frac{37}{113} - \frac{9}{131}; \\
 \text{k)} \frac{1}{151} + \frac{9}{153}; & \text{l)} \frac{8}{15} \cdot \frac{19}{151}; & \text{m)} \frac{12}{121} \cdot \frac{11}{144}; \\
 \text{n)} \frac{9}{113} \cdot \frac{15}{101}; & \text{o)} \frac{19}{38} : \frac{15}{49}; & \text{p)} \frac{121}{49} : \frac{11}{7}.
 \end{array}$$

2.35. Ifodaning qiymatini toping:

$$\begin{array}{ll}
 \text{a)} \left(45\frac{1}{2} - 2\frac{3}{8}\right) - \left(5\frac{5}{6} + 6\frac{3}{4}\right) + \left(10\frac{2}{3} - 5\frac{5}{8}\right); & \\
 \text{b)} \left(36\frac{4}{5} - 12\frac{3}{10}\right) - \left(4\frac{2}{15} + 1\frac{1}{30}\right) - \left(20\frac{11}{12} - 10\frac{3}{8} - \frac{3}{16} - 3\frac{1}{48}\right); & \\
 \text{d)} \left(12\frac{1}{2} - 3\frac{5}{6}\right) - \left(2\frac{8}{9} + 1\frac{4}{5}\right) - \left(5\frac{5}{8} - 4\frac{3}{4}\right) - \left(6\frac{9}{40} - 5\frac{11}{90}\right); & \\
 \text{e)} 56\frac{2}{21} - \left\{\left(1\frac{5}{6} + 2\frac{13}{14}\right) + \left[27\frac{13}{30} - \left(15\frac{5}{12} - 12\frac{13}{20}\right)\right]\right\}; & \\
 \text{f)} \frac{4}{5} \cdot \frac{3}{8} \cdot \frac{3}{5} \cdot \frac{2}{3}; & \text{g)} 3\frac{1}{3} \cdot 3\frac{13}{53} \cdot 3\frac{1}{88}; \\
 \text{h)} 5\frac{1}{4} : 1\frac{2}{7} : 5\frac{1}{2} \cdot \frac{3}{22}; & \text{i)} \left(1\frac{11}{24} + 1\frac{13}{56}\right) \cdot 9 : 1\frac{2}{5}; \\
 \text{j)} \frac{8\frac{1}{2}}{15 : \frac{5}{17}}; & \text{k)} \frac{28 : \frac{7}{29}}{\frac{7 : \frac{1}{9}}{9}}; & \text{l)} \frac{4\frac{4}{5} : \frac{4}{17}}{3\frac{2}{5}}; \\
 \text{m)} 8\frac{13}{16} \cdot \frac{47}{64} : 1\frac{1}{35} : 3\frac{1}{2}. &
 \end{array}$$

2.36. a) $2 : \frac{3}{5} + \frac{3}{5} : 2 + 1\frac{1}{2} : 6 + 6 : \frac{1}{2};$
 b) $6\frac{1}{4} \cdot 8 - 3\frac{2}{3} \cdot 5\frac{1}{2} + 2\frac{2}{5} \cdot 4\frac{7}{12};$
 d) $2\frac{1}{2} \cdot 48 - 3\frac{3}{8} : \frac{1}{18} + 5\frac{5}{12} : \frac{7}{36};$
 e) $13\frac{1}{2} : 1\frac{1}{3} + 16\frac{1}{2} \cdot 1\frac{5}{11} + 19\frac{1}{4} : \frac{4}{25}.$

2.37. a) $\left(3\frac{1}{2} - 2\frac{2}{3} + 5\frac{5}{6} + 4\frac{3}{5}\right) \cdot 24;$

$$b) \left(5\frac{5}{8} + 18\frac{1}{2} - 7\frac{5}{24}\right) : 16\frac{2}{3};$$

$$d) \left(12\frac{5}{12} + 1\frac{2}{3} - 3\frac{5}{6} + 2\frac{2}{3}\right) : \left(2\frac{1}{2} \cdot \frac{2}{5} - \frac{7}{9}\right);$$

$$e) 48\frac{3}{8} \cdot 6\frac{3}{4} \cdot \frac{5}{12} - 2\frac{5}{6} + 1\frac{75}{94} \cdot \left(1\frac{1}{2} \cdot \frac{1}{3} - 13 : 26\right).$$

$$2.38. a) \left(\frac{5}{7} \cdot 2\frac{1}{3} \cdot \frac{5}{6} - 1\right) : \left(1 - \frac{7}{8} \cdot 1\frac{3}{5} \cdot \frac{3}{14}\right);$$

$$b) \left(8\frac{7}{15} - 3\frac{3}{4} + 4\frac{2}{3} - 8\frac{7}{60}\right) : \left(4\frac{1}{4} - 2\frac{3}{4}\right);$$

$$d) \left(1\frac{8}{13} \cdot \frac{13}{42} + 5\frac{5}{7} : \frac{8}{21}\right) : \left(8\frac{1}{8} + 3\frac{1}{3}\right);$$

$$e) 2\frac{3}{5} : 6\frac{1}{15} + 1\frac{1}{14} - 1\frac{39}{73} \cdot \left(5\frac{5}{7} - 5\frac{5}{16}\right).$$

$$2.39. a) \frac{12\frac{4}{5} \cdot 3\frac{3}{4} - 4\frac{4}{11} \cdot 4\frac{1}{8}}{11\frac{2}{3} : 4\frac{4}{7}};$$

$$b) \frac{28\frac{4}{5} : 13\frac{5}{7} + 6\frac{3}{5} \cdot \frac{2}{3}}{1\frac{11}{16} : 2\frac{1}{4}};$$

$$d) \frac{2\frac{3}{8} : \frac{3}{4} + 24\frac{7}{9}}{7\frac{1}{8} - 175\frac{4}{8} : 24};$$

$$e) \frac{\left(1\frac{1}{2} + 2\frac{2}{3} + 3\frac{3}{4}\right) \cdot 3\frac{3}{5}}{14 - 15\frac{1}{8} : 2\frac{1}{5}};$$

$$f) \frac{14\frac{4}{5} - 6\frac{11}{12} + 12\frac{3}{4} - 7\frac{2}{15}}{1\frac{11}{16} : 2\frac{1}{4}};$$

$$g) \frac{1\frac{9}{16} \cdot 3\frac{1}{5} + 16\frac{2}{3} - 9 : 2\frac{2}{5}}{17\frac{7}{12} - 6\frac{1}{3}} + \frac{12\frac{2}{3} - 61\frac{1}{2} : 6\frac{3}{4}}{2\frac{2}{3}}.$$

2. O'nli kasrlar. Agar oddiy kasrning maxraji 10 ning biror natural ko'rsatkichli darajasiga teng bo'lsa, u holda bunday kasr o'nli kasr deyiladi.

Masalan, $\frac{1}{10}$, $\frac{2}{10}$, $\frac{11}{100}$, $\frac{125}{1000}$ va hokazo kasrlar o'nli kasrlardir. O'nli kasrlarni maxrajsiz yozish qabul qilingan. Masalan, yuqoridagi kasrlarni mos ravishda 0,1; 0,2; 0,11; 0,125 ko'rinishda yozish mumkin. Bunday o'nli kasrlar *chekli o'nli kasrlardir*.

Agar $\frac{a}{b}$ qisqarmas kasrning maxrajini $2^m \cdot 5^n$ ($m, n \in N_0$) ko'rinishda tasvirlash mumkin bo'lsa, u holda bu kasr chekli o'nli kasrga aylanadi.

Masalan,

$$\frac{3}{40} = \frac{3}{2^3 \cdot 5} = \frac{3 \cdot 5^2}{2^3 \cdot 5^3} = \frac{75}{10^3} = 0,075$$

yoki

$$\frac{8}{625} = \frac{8}{5^4} = \frac{7 \cdot 2^4}{5^4 \cdot 2^4} = \frac{112}{10^4} = 0,0112.$$

Agar $\frac{a}{b}$ qisqarmas kasr maxrajini $2^m \cdot 5^n$ ($m, n \in N_0$) ko'rinishda tasvirlash mumkin bo'lmasa, u holda $\frac{a}{b}$ kasr chekli o'nli kasrga aylanmaydi. Masalan, $\frac{4}{9}$, $\frac{7}{12}$, $\frac{5}{11}$ va $\frac{35}{44}$ kasrlarni chekli o'nli kasrlar ko'rinishida yozish mumkin emas. Oddiy kasrni o'nli kasrga aylantirish kasrning suratini uning maxrajiga bo'lish bilan ham bajarilishi mumkin. Bundan kelib chiqadiki, agar a va b lar o'zaro tub bo'lsa, a ni b ga bo'lish jarayoni b sonini $2^m \cdot 5^n$ ko'rinishida tasvirlash mumkin bo'lgan holdagina cheklidir.

Ta'rif. $\frac{m}{n}$ ko'rinishida yozish mumkin bo'lgan har qanday son ratsional son deb ataladi, bunda $m \in Z$ va $n \in Z$. Ratsional sonlar to'plamini Q bilan belgilaymiz: $Q = \{a \mid a = \frac{m}{n}, m \in Z, n \in N\}$. Ratsional sonlar to'plami barcha butun va kasr sonlardan tashkil topgan bo'lib, uni manfiy ratsional sonlarning Q_- , faqat 0 dan iborat bir elementli $\{0\}$ va musbat ratsional sonlarning Q_+ to'plamlari birlashmasi (yig'indisi) ko'rinishda tasvirlash mumkin:

$$Q = Q_- \cup \{0\} \cup Q_+.$$

Har qanday ratsional sonni cheksiz o'nli kasr ko'rinishida yozish mumkin. $\frac{m}{n}$ sonini shunday yozish uchun m ni n ga «burchakli» bo'lish kerak. Masalan, 1 ni 3 ga bo'lib, 0,333 ... 3 ...

cheksiz o'nli kasrni hosil qilamiz. Demak, $\frac{1}{3} = 0,333 \dots 3 \dots$. Shu kabi $\frac{1}{7} = 0,14857142857 \dots$ va $\frac{8}{45} = 0,1777 \dots$ bo'lishiga ishonch hosil qilamiz.

Bu misollarning har birida, biror joydan boshlab, biror raqami yoki raqamlari ma'lum bir tartibda takrorlanadigan cheksiz o'nli kasr hosil bo'ldi.

Agar cheksiz o'nli kasrning biror joyidan boshlab, biror raqam yoki raqamlar guruhi ma'lum bir tartibda cheksiz takrorlansa, bunday o'nli kasr *davriy o'nli kasr* deyiladi. Takrorlanuvchi raqam yoki raqamlar guruhi shu kasrning *davri* deb ataladi.

Odatda, davriy o'nli kasrning davri qavs ichiga olingan holda bir marta yoziladi: $0,666 \dots = 0,(6)$; $0,131131131131 \dots = 0,(131)$; $0,1777 \dots 7 \dots = 0,1(7)$.

Shunday qilib, har qanday oddiy kasr va demak, har qanday ratsional son *davriy o'nli kasr* bilan ifodalanadi.



M a s h q l a r

Ifodaning qiymatini toping.

- 2.40.** a) $4,735 : 0,5 + 14,95 : 1,3 - 2,121 : 0,7$;
 b) $589,72 : 16 - 18,305 : 7 + 0,0567 : 4$;
 d) $3,006 - 0,3417 : 34 - 0,875 : 125$;
 e) $22,5 : 3,75 + 208,45 - 2,5 : 0,004$.
- 2.41.** a) $(0,1955 + 0,187) : 0,085$;
 b) $15,76267 : (100,6 + 42697)$;
 d) $(86,9 + 667,6) : (37,1 + 13,2)$;
 e) $(9,09 - 900252) \cdot (25,007 - 12,507)$.
- 2.42.** a) $(0,008 + 0,992) \cdot (5 \cdot 0,6 - 1,4)$;
 b) $(0,93 + 0,07) \cdot (0,93 - 0,805)$;
 d) $(50\ 000 - 1\ 397,3) : (20,4 + 33,603)$;
 e) $(2\ 779,6 + 8\ 024) : (1,98 + 2,02)$.
- 2.43.** a) $\frac{4,06 \cdot 0,0058 + 3,3044895 - (0,7584 : 2,37 + 0,0003 : 8)}{0,03625 \cdot 80 - 2,43}$;

$$b) \frac{2,045 \cdot 0,033 + 10,518395 - 0,464774 : 0,0562}{0,00309 : 0,0001 - 5,188},$$

$$d) \frac{57,24 \cdot 3,55 + 430,728}{2,7 \cdot 1,88 - 1,336} + \frac{127,18 \cdot 4,35 + 14,067}{18 + 2,1492 : 3,582},$$

$$e) 52 : \left(\frac{6 : (0,4 - 0,2)}{2,5 \cdot (0,8 + 1,2)} + \frac{(34,06 - 33,81) \cdot 4}{6,48 : (28,57 - 25,15)} \right) - 8.$$

2.44. Oddiy kasr maxrajini tub ko'paytuvchilarga ajratish bilan uni o'nli kasrga aylantiring:

$$\frac{1}{2}, \frac{1}{5}, \frac{1}{4}, \frac{3}{4}, \frac{1}{8}, \frac{5}{16}, \frac{7}{25}, \frac{23}{25}, \frac{6}{125}, \frac{3}{40}, 11 \frac{7}{80}, 4 \frac{3}{200}, 7 \frac{31}{500}.$$

2.45. Oddiy kasrni uning suratini maxrajiga bo'lish yordamida kasrni o'nli kasrga aylantiring:

$$a) \frac{9}{15}, \frac{18}{252}, \frac{11}{28}, \frac{39}{65}, \frac{30}{75}, \frac{6}{48}, 2 \frac{3}{48}, 5 \frac{192}{575}, 12 \frac{177}{1500};$$

$$b) \frac{8}{5}, \frac{25}{16}, \frac{47}{32}, \frac{263}{250}, \frac{312}{125}, 1 \frac{711}{625}, 5 \frac{2541}{2000}, 4 \frac{7359}{5000}, 3 \frac{23}{25000}.$$

3. Davriy o'nli kasrlarni oddiy kasrlarga aylantirish. Chek-siz o'nli davriy kasrlarni 10, 100, 1000 va h.k. larga ko'paytirish amalini chekli o'nli kasrlardagi kabi vergulni ko'chirish bilan bajarish mumkin. Bundan foydalanib, har qanday davriy kasrni oddiy kasrga aylantirish mumkin.

Masalan, $x = 0,(348) = 0,348348348\dots$ davriy kasrni oddiy kasrga aylantiraylik. Davr uch raqamli bo'lganligi uchun kasrni 1000 ga ko'paytiramiz: $1000x = 348,348348\dots = 348 + x$. Bundan $999x = 348$

$$\text{yoki } x = \frac{348}{999} = \frac{116}{333}.$$

$0,00(348)$ o'nli kasr esa $0,(348)$ dan 100 marta kichik, shunga ko'ra $0,00(348) = \frac{348}{99\ 900}$ bo'ladi. $0,96(348)$ kasrni esa $0,96 + 0,00(348)$ yig'indi ko'rinishida yozish mumkin, u holda

$$\frac{96}{100} + \frac{348}{99\ 900} = \frac{96 \cdot 999 + 348}{99\ 900} = \frac{96\ 000 + 348 - 96}{99\ 900} = \frac{96\ 348 - 96}{99\ 900}.$$

Davriy oʻnli kasrlarni oddiy kasrlarga aylantirishning umumiy qoidasini taʼriflaymiz.

Sof davriy kasr shunday oddiy kasrga tengki, uning surati davrdan, maxraji esa davrda nechta raqam boʻlsa, shuncha marta takrorlanadigan 9 raqami bilan ifodalanadigan sondan iborat.

$$\text{Masalan, } 0,(5) = \frac{5}{9}; \quad 0,(45) = \frac{45}{99}.$$

Aralash davriy kasr shunday oddiy kasrga tengki, uning surati ikkinchi davrgacha turgan son bilan birinchi davrgacha boʻlgan son ayirmasidan, maxraji esa davrda nechta raqam boʻlsa, shuncha marta takrorlangan 9 raqami va buning oxiriga vergul bilan birinchi davr orasida nechta raqam boʻlsa, shuncha marta yozilgan nollar bilan ifodalanadigan sondan iborat.

$$\text{Masalan, } 0,3(45) = \frac{345 - 3}{990} = \frac{342}{990} = \frac{171}{495}.$$



M a s h q l a r

2.46. Quyidagi sonlar berilgan:

$$\frac{1}{3}; \frac{1}{4}; \frac{1}{6}; \frac{1}{12}; \frac{3}{32}; \frac{4}{21}; \frac{5}{54}; \frac{11}{90}; 12\frac{7}{50}; \frac{3}{6}; \frac{15}{45}; \frac{9}{27};$$

a) chekli oʻnli kasrga aylanadigan sonlar toʻplamini tuzing;

b) cheksiz oʻnli kasrga aylanadigan sonlar toʻplamini tuzing.

2.47. Quyidagi sonlarni davriy oʻnli kasr koʻrinishida yozing:

$$1; 1,4; \frac{7}{8}; \frac{13}{26}; \frac{81}{243}; \frac{15}{43}; \frac{71}{16}; \frac{1}{25}; \frac{15}{39}; \frac{41}{43}; 19.$$

2.48. Davriy oʻnli kasrni oddiy kasrga aylantiring:

- | | | |
|--------------|--------------|------------------|
| a) 0,(3); | f) 13,0(48); | j) 2,(123); |
| b) 0,3(2); | g) 0,(4); | k) 2,333(45); |
| d) 0,71(23); | h) 0,(45); | l) 41,8519(504); |
| e) 11,(75); | i) 3,1(44); | m) 35,73(4845). |

2.49. Ifodaning qiymatini toping:

$$\text{a) } \frac{0,8333 \dots - 0,4(6)}{1\frac{5}{6}} + \frac{1,125 + 1,75 - 0,41(6)}{0,59};$$

$$\begin{aligned} \text{b) } & \frac{\left(\frac{5}{8} + 2,708333 \dots\right) : 2,5}{(1,3 + 0,7(6) + 0,(36)) \cdot \frac{110}{401}} \cdot \frac{1}{2}; \\ \text{d) } & \frac{\left(2\frac{38}{45} - \frac{1}{15}\right) : 13\frac{8}{9} + 3\frac{3}{65} - 0,(26)}{(18,5 - 13,777 \dots) \cdot \frac{1}{85}} \cdot 0,5; \\ \text{e) } & \frac{\frac{3}{4} + 0,8(5) \cdot \frac{1}{2}}{9 : (0,9(23) - 0,7(9))} + \frac{41}{43}. \end{aligned}$$

3- §. Haqiqiy sonlar va ular ustida amallar

1. Irratsional sonlar. Qisqarmas kasr shaklida ifodalab bo'lmaydigan sonlar, ya'ni *irratsional sonlar* ham uchraydi.

1- m i s o l. Tomoni 1 ga teng bo'lgan kvadratning d diagonali hech qanday ratsional son bilan ifodalanmasligini isbot qilamiz (9- rasm).

I s b o t. Pifagor teoremasiga muvofiq $d^2 = 1^2 + 1^2 = 2$. Diagonalni $\frac{m}{n}$ qisqarmas kasr ko'rinishida yozish mumkin, deb faraz qilaylik. U holda $\left(\frac{m}{n}\right)^2 = 2$ yoki $m^2 = 2n^2$. Bunga ko'ra m — juft son, $m = 2k$. Shuningdek, $(2k)^2 = 2n^2$ yoki $2k = n$, ya'ni n ham juft son. $\frac{m}{n}$ kasrning surat va maxraji 2 ga qisqarmoqda, bu esa qilingan farazga zid. Demak, d ning uzunligi, ya'ni $\sqrt{2}$ soni ratsional son emas.

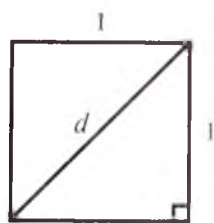

9- rasm.

2- m i s o l. 0,101001000100001000001... soni irratsional son ekanini isbotlang (birinchi birdan keyin bitta nol, ikkinchi birdan keyin ikkita nol va hokazo).

I s b o t. Berilgan kasr davriy va uning davri n ta raqamdan iborat deb faraz qilaylik (teskari faraz). $2n + 1$ -birni tanlaymiz. Bu birdan keyin $2n + 1$ ta ketma-ket nollar keladi:

$$\dots \underbrace{100\dots 0}_{n \text{ ta}} \quad \boxed{0} \quad \underbrace{0\dots 001\dots}_{n \text{ ta}}$$

Shu o'rtada turgan 0 ni qaraymiz. Bu nol biror davrning yo boshida, yoki ichida, yoki oxirida keladi. Bu hollarning hammasida bu davr ajratilgan nollardan tuzilgan «kesma»da to'la joylashadi. Demak, davr faqat nollardan tuzilgan. Bunday bo'lishi esa sonning tuzilishiga zid. Demak, qilingan faraz noto'g'ri.

Barcha ratsional va irratsional sonlar birgalikda *haqiqiy sonlar* deyiladi.

Haqiqiy sonlar to'plami R orqali belgilanadi. Manfiy va musbat haqiqiy sonlar to'plamlarini mos ravishda R_-, R_+ lar bilan belgilab, $R = R_- \cup \{0\} \cup R_+$ tenglikka ega bo'lamiz.

Sonlarning ildiz ishorasi orqali yozilishi ularning kattaligini aniq bilishga yetarli emas. Masalan, hisoblashsiz $\sqrt{2}$ va $\sqrt[3]{3}$ lardan qaysi birining kattaligini aytish qiyin. Bu holda $\sqrt[3]{3} = 1,442\dots$, $\sqrt{2} = 1,4142\dots$ kabi *davriy bo'lmagan cheksiz o'nli kasr* ko'rinishdagi yozuv oydinlik kiritadi, lekin hisoblashlarni qiyinlashtiradi. Shunga ko'ra irratsional sonni unga yaqin ratsional son orqali taqribiy ifodalashga harakat qilinadi. Chunonchi:

1) α irratsional sonni undan kichik a_1 (quyi chegara) va undan katta a_2 (yuqori chegara) ratsional sonlar orqali $a_1 < \alpha < a_2$ ko'rinishda yozish. Bu holda vujudga keladigan xato $\varepsilon \leq |a_2 - a_1|$ dan oshmaydi. Masalan, $1,41 < \sqrt{2} < 1,42$, $\varepsilon \leq |1,42 - 1,41| = 0,01$;

2) ba'zan α uchun $a = (a_2 + a_1)/2$ o'rta qiymat olinadi, $\alpha \approx a$. O'rta qiymatdagi *absolut xato* $\Delta a \leq (a_2 - a_1)/2$, irratsional son esa $\alpha \approx a \pm \Delta a$ ko'rinishda yoziladi. Masalan, $1,41 < \sqrt{2} < 1,42$ bo'lgani uchun

$$\sqrt{2} = \frac{1,42 + 1,41}{2} = 1,415, \quad \Delta = \frac{1,42 - 1,41}{2} = 0,005$$

Shunga ko'ra $\sqrt{2} \approx 1,415 \pm 0,005$. Sonni yaxlitlashdan vujudga keladigan haqiqiy xato qoldirilayotgan raqam xonasi 1 birligidan oshmaydi. $\sqrt{2} \approx 1,42$ taqribiy son xatosi $\varepsilon = 1,4142\dots - 1,42 = -0,0057 \approx -0,6 \cdot 10^{-2}$.

$1,41 < \sqrt{2} < 1,42$ bo'lganidan $\sqrt{2}$ ning $(1,41; 1,42)$ dan olinadigan qiymatlari to'plami *chegaralangandir*. Shu kabi, uzunligi C ga teng bo'lgan aylana ichiga chizilgan barcha qavariq n - burchaklarning $p = p_n$ perimetrlari C dan kichik, ya'ni $P = \{p \mid p = p_n, n = 3, 4, 5, \dots, p_n < C\}$ to'plam chegaralangan va son ko'rinishda beriladi.

3- misol. π soni kattami yoki $\sqrt{10}$ mi?

Ye ch ish. Masala $\pi = 3,14159\dots$ va $\sqrt{10} = 3,16227\dots$ sonlarining mos xonalari raqamlarini (o'nli yaqinlashishlarini) taqqoslash orqali hal bo'ladi. Ularning butun qismlari va o'ndan birlar xonasi raqamlari bir xil, lekin 0,01 lar xonasi raqami $\sqrt{10}$ da katta. Demak, $\pi < \sqrt{10}$.

4- misol. $\sqrt{2} + \sqrt{5}$ – irratsional son ekanligini isbotlang.

Isbot. $\sqrt{2} + \sqrt{5}$ ratsional son deb faraz qilaylik, ya'ni

$$\sqrt{2} + \sqrt{5} = r, \quad r \in Q. \quad \sqrt{5} = r - \sqrt{2} \Rightarrow 5 = r^2 - 2\sqrt{2}r + 2 \Rightarrow$$

$$\Rightarrow 3 = r^2 - 2\sqrt{2}r \Rightarrow r^2 - 3 = 2\sqrt{2}r \Rightarrow \sqrt{2} = \frac{r^2 - 3}{2r} \in Q;$$

lekin $\sqrt{2} \notin Q$. Zidlik hosil bo'ldi. Faraz noto'g'ri.

Demak, $\sqrt{2} + \sqrt{5}$ irratsional son.



Mashqlar

2.50. Quyidagi sonlarning irratsional son ekanini isbot qiling:

- a) $\sqrt{3}$; b) $\sqrt{5}$; d) $\sqrt{7}$; e) $\sqrt{2} + \sqrt{3}$; f) $\sqrt[3]{2}$;
 g) $\sqrt[3]{4}$; h) $\sqrt[3]{2,1}$.

2.51. $5^r = 2$ tenglikni qanoatlantiruvchi hech qanday r ratsional soni mavjud emasligini isbot qiling.

2.52. Agar biror a butun son boshqa hech qanday butun sonning kvadrati bo'lmasa, u hech qanday ratsional sonning kvadrati bo'lolmasligini isbot qiling.

2.53. a) a va b sonlar ratsional sonlar;
b) a va b sonlar irratsional sonlar;
d) a ratsional son, b irratsional son bo'lsa, $a + b$ va $a \cdot b$ sonlarning ratsional yoki irratsional ekanligi haqida nima deyish mumkin?

2.54. a) Agar p, q – butun sonlari uchun $p + q\sqrt{3} = 0$ bo'lsa, $p = q = 0$ bo'lishini isbotlang;

b) agar p, q – butun sonlari uchun $p^2 - 9q^2 = 6q$ bo'lsa, $p = q = 0$ bo'lishini isbotlang;

d) Agar p, q – butun sonlari uchun $p^2 - 4q^2 = 4pq$ bo'lsa, $p = q = 0$ bo'lishini isbotlang;

e) a, b, c ratsional sonlari uchun $a + b\sqrt{2} + c\sqrt{4} = 0$ bo'lsa, $a = b = c = 0$ bo'lishini isbotlang.

2.55. α, β lar irratsional sonlar, r esa ratsional son bo'lsin. Quyidagi sonlarning qaysilari ratsional son bo'lib qolishi mumkin:

a) $\alpha + \beta$; b) $\alpha + r$; d) $\sqrt{\alpha}$; e) \sqrt{r} ;

f) $\alpha \cdot \beta$; g) $\sqrt{\alpha + r}$; h) $\sqrt{\alpha + \sqrt{r}}$?

2.56. Ushbu sonlarning ratsional son emasligini isbot qiling:

a) 0,81881888188881...;

b) $-3,5755775557775557777...$

2. Sonli to'plamlarni ajratuvchi son. X va Y sonli to'plamlar bo'sh bo'lmasin. Agar X ning $\forall x$ elementi Y ning $\forall y$ elementidan kichik bo'lsa, Y to'plam X to'plamdan o'ngda joylashgan bo'ladi, bunda \forall – ixtiyoriylik belgisi. Agar $\forall x \in X$ va $\forall y \in Y$ elementlar uchun $x \leq c \leq y$ tengsizligi bajarilsa, c soni

shu to'plamlarni *ajratuvchi son* deyiladi. Bu holda Y to'plam c dan o'ngda joylashadi. Masalan, $X = \{3; 7\}$ va $Y = \{9; 12\}$ to'plamlarni $c = 8$ soni ajratadi va bunda Y to'plam c ning o'ng tomonida, X esa c ning chap tomonida joylashadi. Agar Y to'plam X to'plamdan o'ngda joylashsa, bu to'plamlarni ajratuvchi kamida bitta son mavjud bo'ladi.

Oliy matematika kursida quyidagi teorema isbot qilinadi.

T e o r e m a . *Natural sonlar to'plamida berilgan $Y = \{y_n\}$ to'plam $X = \{x_n\}$ to'plamdan o'ngda joylashgan, ya'ni $x_n < y_n$ bo'lsin. X va Y larni ajratuvchi faqat bitta c soni mavjud bo'lishi uchun $y_n - x_n$ ayirmalar har qancha kichik bo'la oladigan, ya'ni X va Y lar bir-birlariga har qancha yaqin joylasha oladigan bo'lishi zarur va yetarli.*

1- m i s o l . $(3; 5)$ va $(7; 9)$ oraliqlar $(5; 7)$ oraliqqa qarashli ixtiyoriy son bilan ajraladi. $(3; 5)$ va $(7; 9)$ oraliqlarning nuqtalaridan tuzilgan ixtiyoriy oraliq uzunligi $(5; 7)$ oraliq uzunligidan, ya'ni $7 - 5 = 2$ dan kichik bo'lolmaydi.

2- m i s o l . $[2; 5]$ va $[5; 8]$ kesmalar faqat 5 soni bilan ajraladi, chunki ixtiyoriy n natural son uchun $\left[5 - \frac{1}{n}; 5 + \frac{1}{n}\right]$ oraliq uzunligi $\frac{2}{n}$ ga teng. n ning yetarlicha katta qiymatlarida bu uzunlik har qancha kichik bo'ladi.



M a s h q l a r

2.57. X va Y to'plamlar juftlarini ajratuvchi barcha sonlarni toping:

a) $X = \{\text{«}R \text{ radiusli aylanaga ichki chizilgan qavariq ko'pburchaklar perimetrlari}\}$, $Y = \{\text{«}Shu aylanaga tashqi chizilgan qavariq ko'pburchaklar perimetrlari}\}$;

b) $X = \{\text{«}r < R \text{ radiusli aylanaga ichki chizilgan qavariq ko'pburchaklar perimetrlari}\}$, $Y = \{\text{«}r < R \text{ radiusli aylanaga tashqi chizilgan qavariq ko'pburchaklar perimetrlari}\}$;

d) $X = \left\{3 - \frac{1}{n} \mid n \in N\right\}$, $Y = \left\{3 + \frac{1}{n} \mid n \in N\right\}$;

e) $X = \left\{6 - \frac{10}{n} \mid n \in N\right\}$, $Y = \left\{6 + \frac{10}{n} \mid n \in N\right\}$.

3. Haqiqiy sonlar ustida arifmetik amallar. $\sqrt{2}$ sonining 10^{-n} gacha kami (quyi chegara) va ortig'i (yuqori chegara) bilan olingan bir necha yaqinlashishlarini kuzataylik: $1,4 < \sqrt{2} < 1,5$, $1,41 < \sqrt{2} < 1,42$, $1,414 < \sqrt{2} < 1,415$. Kami bilan olingan o'nli yaqinlashishlar o'suvchi, ortig'i bilan olinganlari esa kamayuvchi ketma-ketlik tashkil etmoqda. Uning hadlaridan iborat ikki to'plamni yagona $\sqrt{2}$ soni ajratib turadi. Arifmetik amallarni bajarish va topilgan natijalarni baholashda sonlarning bu xususiyati e'tiborga olinadi.

Agar A , B va hokazo sonlar $a_n < A < a'_n$ kabi ko'rinishda berilgan bo'lsa, ular ustida amallarni bajarishda tengsizliklarning ma'lum xossalardan foydalanamiz, bunda a_n va a'_n lar A ning 10^{-n} gacha kami va ortig'i bilan olingan o'nli yaqinlashishlari, $n \in \mathbb{N}$. Natija $x_n < X < x'_n$ qo'shtengsizlik yoki $X = x \pm \Delta x$, yoki $X \approx x$ ko'rinishida yoziladi. Bu yozuvlarning biridan ikkinchisiga o'tish mumkinligini bilamiz. Xususan, $x_n < X < x'_n$ bo'yicha X

ning $x = \frac{x_n + x'_n}{2}$ o'rtacha (taqribiy) qiymati va uning $\Delta x = \frac{x'_n - x_n}{2}$

chegaraviy (eng katta) absolut xatosini hisoblash orqali $X = x \pm \Delta x$ ga o'tish va aksincha, $X = x \pm \Delta x$ bo'yicha $x - \Delta x < X < x + \Delta x$ qo'shtengsizlikka o'tish mumkin. $X \approx x$ yozuvda x ning qanday aniqlikda berilganligi nazarga olinadi. Masalan, $\pi \approx 3,14$ soni $3,14 < \pi < 3,15$, $\pi \approx 3,145 \pm 0,005$ ko'rinishda yozilishi mumkin. Shuni esda tutish kerakki, taqribiy son quyi chegara qiymati faqat kami bilan, yuqori chegara qiymati esa ortig'i bilan yaxlitlanishi mumkin.

1) qo'shish:

$$\begin{array}{r}
 a_n < \alpha < a'_n \\
 + \\
 b_m < \beta < b'_m \\
 \hline
 \dots\dots\dots \\
 x < X < x'
 \end{array}$$

yoki qisqaroq

$$\begin{array}{c|c}
 + a_n & a'_n \\
 + b_m & b'_m \\
 \hline
 \dots & \dots \\
 x & x'
 \end{array}$$

Bunda $x = a_n + b_m + \dots$, $x' = a'_n + b'_m + \dots$.

α va β sonlarining $\alpha + \beta$ yig'indisi deb ularning kami bilan olingan ketma-ket o'suvchi α_n va β_n ($n \in N$) yaqinlashishlari yig'indilari A to'plami va ortig'i bilan olingan a'_n va b'_n ketma-ket kamayuvchi o'nli yaqinlashishlarining yig'indilari B to'plamini ajratuvchi $\alpha + \beta$ songa aytiladi: $a_n + b_n < \alpha + \beta < a'_n + b'_n$.

2- band (qisqacha b.) teoremasiga ko'ra A va B to'plamlarni ajratuvchi kamida bitta son mavjud. Lekin u yagona. Haqiqatan,

$$a'_n = a_n + \frac{1}{10^n}, \quad b'_n = b_n + \frac{1}{10^n}, \quad \varepsilon = (a'_n + b'_n) - (a_n + b_n) = \frac{2}{10}$$

bo'ladi va n ning katta qiymatlarida ε istalgancha kichrayadi.

2) qarama-qarshi ma'noda yozilgan α va β sonlarni ayirish:

$$\begin{array}{r} a_n < \alpha < a'_n \\ b'_n > \beta > b_n \end{array}$$

.....

$$a_n - b'_n < \alpha - \beta < a'_n - b_n.$$

3) α va β musbat sonlarning $\alpha\beta$ ko'paytmasi deb, $a_n b_n$ ko'paytmalar A to'plami va $a'_n b'_n$ ko'paytmalarning B to'plamini ajratuvchi $\alpha\beta$ songa aytiladi, ya'ni $a_n b_n < \alpha\beta < a'_n b'_n$, $n \in N$.

4) α musbat haqiqiy songa *teskari* son deb, $a_n \neq 0$, $a'_n \neq 0$ bo'lganda $\frac{1}{a_n}$ sonlarning A to'plami va $\frac{1}{a'_n}$ sonlarning B to'plamini ajratuvchi $\frac{1}{\alpha}$ songa aytiladi: $\frac{1}{a'_n} < \frac{1}{\alpha} < \frac{1}{a_n}$. Bunday son mavjud va yagona. Haqiqatan, $0 < \alpha_n < \alpha'_n$, bundan $\frac{1}{a'_n} < \frac{1}{a_n}$, bu esa B to'plamning A to'plamdan o'ngda joylashganligini bildiradi.

Demak, A va B ni ajratuvchi son mavjud. U yagona hamdir.

Haqiqatan, $a'_n = a_n + \frac{1}{10}$, $0 < a_n < a'_n$ ekanidan $\frac{1}{a'_n} - \frac{1}{a_n} =$

$\frac{a_n - a_n}{a_n a_n} = \frac{1}{10^n a_n a_n} < \frac{1}{10^n a_1^2}$ bo'ldi va n kattalashgan sari kasr kichiraydi. Demak, $\frac{1}{\alpha}$ — yagona ajratuvchi son.

5) α ni $\beta \neq 0$ ga bo'lishdan hosil bo'ladigan *bo'linma* deb, $\frac{1}{\beta}$ ko'paytmaga aytiladi, ya'ni $a_n \cdot \frac{1}{b'_n} < \frac{\alpha}{\beta} < a'_n \cdot \frac{1}{b_n}$.

$\alpha = a \pm \Delta a$ ko'rinishdagi sonlar ustida amal ikki usulda bajariladi:

1- usul: sonlar qo'shtengsizlik ko'rinishda qaytadan yoziladi, so'ng amal bajariladi.

2- usul: oldin amal a, b, \dots taqribiy qiymatlar ustida bajarilib, x , so'ng alohida formulalar bo'yicha Δx xato qiymati topiladi:

1) yig'indi xatosi: $\Delta(a + b) = \Delta a + \Delta b$, chunki $\alpha + \beta = (a \pm \Delta a) + (b \pm \Delta b) = (a + b) \pm (\Delta a + \Delta b)$;

2) ayirma xatosi: $\Delta(a - b) = \Delta a + \Delta b$, chunki $\alpha - \beta = (a \pm \Delta a) - (b \pm \Delta b) = (a - b) \pm (\Delta a + \Delta b)$;

3) ko'paytma xatosi: $\Delta(ab) \approx b\Delta a + a\Delta b$, chunki $\alpha\beta = (a \pm \Delta a)(b \pm \Delta b) = ab \pm (b\Delta a + a\Delta b)$, bunda nisbatan kichik bo'lganligidan $\Delta a\Delta b$ ko'paytma tashlab yuboriladi. Xususan,

$$\Delta(a^n) = na^{n-1} \cdot \Delta a \text{ va } \Delta\left(\sqrt[n]{a^m}\right) = \frac{m}{n} \cdot a^{n-1} \cdot \Delta a;$$

4) bo'hinmadagi xato $\Delta\left(\frac{a}{b}\right) \approx \frac{b \cdot \Delta a + a \cdot \Delta b}{b^2}$ (mustaqil isbot qiling!).

Agar α taqribiy sonning ε chetlanishi (xatosi) shu sonning biror xonasi 1 birligidan katta bo'lmasa, shu xonada turgan raqam va undan chapda joylashgan barcha raqamlar *ishonchli raqamlar*, o'ng tomonda turgan raqamlar esa *ishonchsiz raqamlar* deyiladi. Ishonchsiz raqamlar yaxlitlab tashlanadi va ular o'rniga 0 lar yoziladi. Son $\alpha \approx a$ ko'rinishida yoziladi. Masalan, $\alpha \approx 28,8569 \pm$

$\pm 0,01$ sonida 28,85 ishonchli raqamlardan iborat, 5, 6, 9 lar esa ishonchsizdir. Shunga ko'ra $\alpha \approx 28,86$.

Ratsional sonlar ustida bajariladigan arifmetik amallarning barcha xossalari haqiqiy sonlar holida ham o'z kuchida qoladi. Ularni eslatib o'tamiz:

$$1) \alpha + \beta = \beta + \alpha; \quad 2) \alpha + (\beta + \gamma) = (\alpha + \beta) + \gamma; \quad 3) \alpha + 0 = \alpha;$$

$$4) \alpha + (-\alpha) = 0; \quad 5) \alpha(\beta + \gamma) = \alpha\beta + \alpha\gamma.$$

$$\text{Shu kabi: } 1') \alpha\beta = \beta\alpha; \quad 2') \alpha(\beta\gamma) = (\alpha\beta)\gamma; \quad 3') \alpha \cdot 1 = \alpha;$$

$$4') \frac{\alpha}{\alpha} = 1, \quad \alpha \neq 0.$$

1- m i s o l . Kuchlanishi 215 ± 15 V bo'lgan elektr tarmog'iga tok kuchi 5 A dan oshmaslik sharti bilan $44 \pm 0,5 \Omega$ qarshilikni ulash mumkinmi?

Y e c h i s h . $I = \frac{U}{R} = \frac{215 \pm 15}{44 \pm 0,5} = \dots = 4,896\dots \pm 0,293\dots \approx 4,89 \pm 0,30$ A yoki $4,59 < I < 5,2$ A , ya'ni I ning yuqori chegara qiymati 5 A dan oshmoqda, demak, ulash mumkin emas.

2- m i s o l . ABC uchburchak tomonlari: $AB = \sqrt{58}$, $BC = \sqrt{85}$, $AC = 9$, uning p perimetrini 0,01 aniqlikda topamiz.

Y e c h i s h . 1- u s u l . Qo'shiluvchilarning aniq qiymatini 0,001 gacha aniqlik bilan olamiz va natijani 0,01 gacha aniqlikda yaxlitlaymiz:

$$p = AB + BC + AC = \sqrt{58} + \sqrt{85} + 9 \approx \\ \approx 7,615 + 9,219 + 9 = 25,834 \approx 25,83.$$

2- u s u l . Qo'shtengsizliklar usuli. Sonlarni quyi va yuqori chegara qiymatlari bo'yicha yozamiz va amalni bajaramiz:

$$\begin{array}{r} 7,61 < \sqrt{58} < 7,62 \\ + \\ 9,21 < \sqrt{85} < 9,22 \\ 9 \qquad 9 \qquad 9 \\ \hline 25,82 < p < 25,84 . \end{array}$$

3- u s u l . Δ absolut xato (yoki nisbiy xato) kattaligini ham hisoblash:

$p = AB + BC + AC = (7,612 \pm 0,005) + (9,220 \pm 0,001) + 9 =$
 $= 25,832 \pm 0,006 \approx 25,83 \pm 0,01$. Agar 2- usul natijalari bo'yicha
o'rtacha qiymatlar topilishi talab qilinsa, u holda:

$$p = \frac{25,84 + 25,82}{2} = 25,83, \quad \Delta p = \frac{25,84 - 25,82}{2} = 0,01,$$

$$p \approx 25,83 \pm 0,01.$$

3- m i s o l . Qadimgi Samarqand madrasalari darsliklarida
 $\pi \approx \frac{22}{7}$ taqribiy son uchraydi. Undagi xato kattaligini baholaylik.

Y e c h i s h . $\varepsilon = \left| \pi - \frac{22}{7} \right| = |3,1415\dots - 3,1428\dots| = 0,0013\dots$
 $\dots < 0,002$.

4- m i s o l . $\alpha \approx 3,2 \pm 0,08$ berilgan. $\sqrt[3]{\alpha^2}$ ni hisoblaymiz.

Y e c h i s h . 1) $\sqrt[3]{3,2^2} = \sqrt[3]{10,24} \approx 2,172$;

$$2) \Delta = \frac{2}{3} \cdot \frac{0,08}{3,2^3} \approx 0,04.$$

J a v o b : $2,17 \pm 0,04$.



M a s h q l a r

- 2.58. $a = \sqrt{3,87}$, $b = \sqrt{3,86}$ bo'lsa, $a + b$, $a - b$, ab , $\frac{a}{b}$ larni
0,01 gacha aniqlikda toping. Ayirmada aniqlikning yo'qolishiga
sabab nima?
- 2.59. Hajmi $710 < V < 720$ (sm^3), zichligi $8,4 < \rho < 8,7$ (kg/m^3)
bo'lgan moddaning massasini toping.
- 2.60. Kubning qirrasini $12,8 < a < 12,9$ (sm). Uning to'liq sirti va
hajmini toping. Javobni qo'shtengsizliklar va taqriban 0,1
gacha aniqlikda yozing.
- 2.61. Kubning hajmi $1450 < V < 1460$ (sm^3). Uning qirrasini
toping.
- 2.62. Haqiqiy sonlar quyidagi xossalarga ega ekanligini isbot qiling:
a) agar $b - a > 0$ bo'lsa va faqat shu holdagina $a < b$ bo'ladi;

- b) hech qanday a soni uchun $a < a$ tengsizligi bajarilmaydi;
- d) agar $a < b$ va $b < c$ bo'lsa, $a < c$ bo'ladi;
- e) ixtiyoriy ikkita a va b sonlari uchun $a = b$, $a < b$, $a > b$ munosabatlardan faqat biri bajariladi;
- f) agar $a < b$ bo'lsa, $a + c < b + c$ bo'ladi; agar $a < b$ va $c < d$ bo'lsa, $a + c < b + d$ bo'ladi;
- g) agar $a < b$ va $c > 0$ bo'lsa, $ac < bc$ bo'ladi; agar $a < b$ va $c < 0$ bo'lsa, $ac > bc$ bo'ladi;
- h) agar $0 < a < b$ va $0 < c < d$ bo'lsa, $ac < bd$ bo'ladi;
- i) agar $a < b$ bo'lsa, $-a > -b$ bo'ladi;
- j) agar $0 < a < b$ bo'lsa, $0 < \frac{1}{b} < \frac{1}{a}$ bo'ladi.

2.63. Ko'p bosqichli raketa birinchi bosqich dvigatelining tortish kuchi $10^6 \pm 10^4$ N ga teng. Shu bosqich ishining oxirida raketa $3000 + 15$ m/s tezlik bilan uchayotgan bo'lsin. O'sha onda dvigatel qanday quvvatga ega bo'lgan? Javobni mln. kW larda bering.

4. Haqiqiy sonning moduli. a haqiqiy sonning moduli deb,

$$|a| = \begin{cases} a, & \text{agar } a \geq 0 \text{ bo'lsa,} \\ -a, & \text{agar } a < 0 \text{ bo'lsa} \end{cases}$$

munosbat bilan aniqlanadigan $|a|$ soniga aytiladi. Uning asosiy xossalari keltiramiz:

$$1) \alpha \leq |\alpha|; \quad 2) |\alpha\beta| = |\alpha| \cdot |\beta|; \quad 3) |\alpha + \beta| \leq |\alpha| + |\beta|;$$

$$4) \left| \frac{1}{\alpha} \right| = \frac{1}{|\alpha|}; \quad 5) |\alpha - \beta| \geq |\alpha| - |\beta|.$$

1- xossaning to'g'riligi modulning ta'rifidan kelib chiqadi.

2- xossani isbot qilamiz:

$$\alpha \leq |\alpha|, \beta \leq |\beta| \Rightarrow |\alpha + \beta|^2 = (\alpha + \beta)^2 = \alpha^2 + 2\alpha\beta + \beta^2 \leq$$

$$\leq (|\alpha| + |\beta|)^2 \Rightarrow |\alpha + \beta| \leq |\alpha| + |\beta|.$$

Tenglik belgisi $\alpha\beta \geq 0$ bo'lgandagina o'rinlidir.



M a s h q l a r

1.64. Haqiqiy son a ning moduli nomanliiy son ekanini isbotlang.

1.65. Taqqoslang:

a) $|8,7|$ va 8 ; f) $-|-3,2|$ va $-3,2$;

b) $|0|$ va 0 ; g) $|a|$ va 0 ;

d) $|-15,2|$ va $15,2$; h) $-5|a|$ va 0 ;

e) $|-6\frac{3}{4}|$ va $-6\frac{3}{4}$; i) $|a|$ va a .

2.66. Harflarning ko'rsatilgan qiymatlarida ifodaning qiymatini hisoblang:

a) $|a| + 2|b|$, $a = -3$, $b = 5$;

b) $|-a| - 2|b|$, $a = -1$, $b = -2$;

d) $\frac{-1 - |-3a| + 4|b|}{2|a| + |b|}$, $a = -4$, $b = 0$;

e) $\frac{4 - |a| + 2|b+1|}{|-a| \cdot |b+3| \cdot |b+1|}$, $a = 2$, $b = -4$;

f) $(-|-a|)^3 + 2|-b|^3$, $a = 1$, $b = 2$.

2.67. Agar a) $|a| = b$, b) $|a| = -b$ bo'lsa, b soni haqida nima deyish mumkin?

2.68. Agar a) $|a| = |b|$, b) $|a| = a$, d) $|b| = -b$ bo'lsa, a va b sonlari haqida nima deyish mumkin?

2.69. Modulning quyidagi xossalarini isbotlang:

a) $a \leq |a|$; f) $|a + b| \leq |a| + |b|$;

b) $-a \leq |a|$; g) $|a - b| \leq |a| + |b|$;

d) $|-a| = |a|$; h) $|a + b| \geq |a| - |b|$;

e) $-|a| \leq a \leq |a|$; i) $|a - b| \geq ||a| - |b||$.

2.70. Tenglikni isbotlang:

a) $|a \cdot b| \leq |a| \cdot |b|$;

d) $|a^2| = |a|^2 = a^2$;

b) $\left|\frac{a}{b}\right| = \frac{|a|}{|b|} (b \neq 0)$;

e) $|a^{2n}| = |a|^{2n} = a^{2n}, n \in N$.

2.71. Ifodani modul belgisiz yozing:

a) $|x - 2|$;

f) $|3x + 7|$;

j) $a + |a|$;

b) $|x + 2|$;

g) $|-3x + 7|$;

k) $2x + |a - 1|$;

d) $|-x + 3|$;

h) $|-3x - 9|$;

l) $3|xy| + a$;

e) $|-x - 4|$;

i) $|4x|$;

m) $2|x - y| + y$.

2.72. Ifodani modul belgisiz yozing:

a) $|x + 1| + |x - 1|$;

f) $|4x - 8| + |x - 2| + |x|$;

b) $|x - 1| - 2|x + 2|$;

g) $|7x - 5| + |2x - 1| + |x - 2|$;

d) $|2x - 1| - |x - 2|$;

h) $|7x + 5| - |3x - 2| + |x - 3|$;

e) $|3x - 7| + |4x - 5|$;

i) $|3x - 6| + |8x - 4| - |13x - 20|$.

2.73. Ifodani modul belgisiz yozing:

a) $||x| - 2|$;

f) $||6x - 1| - |4x + 1||$;

b) $||x - 3| - x|$;

g) $||x - 3| - |x|| - |x - 1|$;

d) $|x - 3 - |x||$;

h) $|x^2 - |x|^2 + |x| - |x - 3||$;

e) $||x - 3| - |x||$;

i) $||3x - 1| - |x|| - |x - 2|$.

2.74. a, b, c, d haqiqiy sonlar bir vaqtda nolga teng emasligini modul belgisidan foydalanib qanday yozish mumkin?

2.75. a, b, c sonlaridan kamida ikkitasi o'zaro teng emasligini modul belgisi yordamida qanday yozish mumkin?

2.76. a, b, c lar o'zaro teng ekanini modul qatnashgan tengsizlik bilan ifodalang.

5. Haqiqiy sonning butun va kasr qismi. a sonining *butun qismi* deb, a dan katta bo'lmagan butun sonlarning eng kattasiga aytiladi va $[a]$ yoki $E(a)$ orqali belgilanadi. O'qilishi: « a ning butun qismi» yoki «antye a » (fransuzcha *entiere* – butun).

1- misol. $[3,2] = [3,8] = 3$; $[0,2] = [0,99] = [0] = 0$; $[-1,2] = [-1,5] = -2$; shu kabi $10\frac{4}{5} + 5\frac{2}{5} = 16\frac{1}{5}$ bo'lgani uchun $[10\frac{4}{5} + 5\frac{2}{5}] = [16\frac{1}{5}] = 16$; $28 \cdot [0,7] = 28 \cdot 0 = 0$; $8 : [2\frac{4}{5}] = 4$; $[\pi] = 3$; $[-\pi] = -4$.

Sonning butun qismi quyidagi xossalarga ega:

1- xossa. $a, b \in Z$ bo'lganda, $[a + b] = [a] + [b]$ bo'ladi.

2- xossa. $a, b \in R$ bo'lganda, $[a + b] \geq [a] + [b]$ bo'ladi.
 $[9 + 10] = [9] + [10] = 19$; $[9,8] + [9,9] = 9 + 9 = 18$. $[9,8 + 9,9] = [19,7] = 19$. $18 < 19$.

$a - [a]$ ayirma a sonining *kasr qismi* deyiladi va $\{a\}$ orqali belgilanadi: $\{a\} = a - [a] > 0$, $0 \leq \{a\} < 1$, bunda $a = [a] + \{a\}$.

2- misol. $\{16\frac{1}{5}\} = \frac{1}{5}$, $\{-1,5\} = \{-2 + 0,5\} = 0,5$; $\{\pi\} = 0,14\dots$

3- misol. Agar $[a] = [b]$ bo'lsa, $-1 < a - b < 1$ bo'lishini isbot qilamiz.

Isbot. $a = [a] + \{a\}$ va $b = [b] + \{b\}$ bo'lganidan $a - b = ([a] + \{a\}) - ([b] + \{b\}) = ([a] - [b]) + (\{a\} - \{b\}) = \{a\} - \{b\}$. Lekin $0 \leq \{a\} < 1$, $0 \leq \{b\} < 1$.

Shunga ko'ra (va qarama-qarshi ma'nodagi tengsizliklarni hadlab ayirish mumkinligiga asoslansak):

$$\begin{array}{r} 0 \leq \{a\} < 1 \\ 1 > \{b\} \geq 0 \\ \hline -1 \leq \{a\} - \{b\} < 1. \end{array}$$

4- misol. Agar a soni butun va nomanfiy bo'lsa, $[na] \geq n[a]$ bo'lishini isbotlang.

Isbot. $[na] = [n([a] + \{a\})] = n[a] + n\{a\}$, bunda $n\{a\} \geq 0$.

Demak, $[na] \geq n[a]$.

5- misol. $1 \cdot 2 \cdot 3 \cdot 4 \cdot 5 \cdot \dots \cdot 2001$ ko'paytma nechta nol bilan tugaydi?

Yechish. Berilgan ko'paytmaning kanonik shakli $2^{\alpha_1} \cdot 3^{\alpha_2} \cdot 5^{\alpha_3} \cdot \dots \cdot p^{\alpha_n}$ bo'lsin. α_1 va α_3 natural sonlarni topamiz.

α_3 soni 1 dan 2001 gacha bo'lgan natural sonlar orasidagi 5, 25, 125, 625 sonlariga bo'linuvchi barcha natural sonlarning soniga teng:

$$\alpha_3 = \left[\frac{2001}{5} \right] + \left[\frac{2001}{25} \right] + \left[\frac{2001}{125} \right] + \left[\frac{2001}{625} \right] = 400 + 80 + 16 + 3 = 499.$$

Xuddi shu kabi

$$\alpha_1 = \left[\frac{2001}{2} \right] + \left[\frac{2001}{4} \right] + \left[\frac{2001}{8} \right] + \dots + \left[\frac{2001}{1024} \right] = 1880$$

ekanini aniqlaymiz.

$2^{1880} \cdot 5^{499}$ ko'paytma 499 ta nol bilan tugagani sababli, berilgan ko'paytma ham 499 ta nol bilan tugaydi.

6- misol. $\left[\frac{x-1}{3} \right] = x$ tenglamani yechamiz.

Yechish. Tushunarliki, $x \in Z$ va $x \leq \frac{x-1}{3} < x+1$ bo'lishi zarur. $x \leq \frac{x-1}{3} < x+1$ tengsizlik $x = -1$ dan iborat yagona butun yechimga ega va bu yechim berilgan tenglamani qanoatlantiradi. Shunday qilib, berilgan tenglama $x = -1$ dan iborat yagona yechimga ega.



M a s h q l a r

2.77. Hisoblang:

- a) $[2,8]$; b) $[2]$; d) $[0]$; e) $[0,9]$; f) $[-1,5]$;

g) $[-0,2]$; h) $[\pi]$; i) $[-\pi]$; j) $[\sqrt{15}]$; k) $[\frac{100}{7}]$.

2.78. Hisoblang:

a) $100 \cdot [\frac{1}{7}]$; f) $8 \cdot [3\frac{2}{3}]$;

b) $[12\frac{2}{7} + 5\frac{3}{7}]$; g) $[\frac{100}{7}] \cdot 7$;

d) $[12\frac{2}{7} + 5\frac{6}{7}]$; h) $[\frac{100}{7^2}] \cdot 7$;

e) $[12\frac{2}{7}] + [5\frac{6}{7}]$; i) $[\frac{490}{100}]^2$.

2.79. Tenglamani yeching:

a) $[\frac{3x-1}{4}] = 5$; d) $[2x+4] = -5$;

b) $[\frac{3x}{4} - 1] = 15$; e) $[3x-1] = -4$.

2.80. Tenglamani yeching:

a) $[\frac{x-1}{2}] = x$; d) $[\frac{2x-1}{3}] = 2x$;

b) $[\frac{3x+1}{2}] = -x$; e) $[3x+1] = \frac{x}{4}$.

2.81. 1, 2, 3, ..., n natural sonlar ketma-ketligida p natural songa bo'linuvchi $[\frac{n}{p}]$ ta had bo'ladi. Isbot qiling.

2.82. $n! = 1 \cdot 2 \cdot \dots \cdot n$ bo'lsa, $600!$ soni nechta nol bilan tugaydi?

2.83. $600!$ yoyilmasida har qaysi 2, 5, 7 tub soni va ularning darajalariga bo'linuvchilarning umumiy soni topilsin.

2.84*. $n!$ soni tub ko'paytuvchilari yoyilmasida p tub soni

$$x = \left[\frac{n}{p} \right] + \left[\frac{n}{p^2} \right] + \left[\frac{n}{p^3} \right] + \dots + \left[\frac{n}{p^m} \right] \text{ marta qatnashadi, bunda}$$

$p^m < n < p^{m+1}$. Shuni isbot qiling.

6. Proporsiya. $a \in R, b \in R \setminus \{0\}$ bo'lsa, $\frac{a}{b}$ ifoda *nisbat* deyiladi.

Ikki nisbatning tengligi *proporsiya* deyiladi. Proporsiya umumiy holda

$$\frac{a}{b} = \frac{c}{d} \quad (1)$$

ko'rinishda yoziladi, bunda $b \neq 0, d \neq 0$. a, d lar proporsiyaning *chetki* hadlari, b, c lar esa *o'rta* hadlari deyiladi.

Proporsiya quyidagi xossalarga ega:

1. $ad \neq bc$;

$$2. \frac{a}{b} = \frac{c}{d} \Rightarrow \begin{cases} \frac{a}{c} = \frac{b}{d}, & \frac{d}{c} = \frac{b}{a}; \\ \frac{d}{b} = \frac{c}{a}. \end{cases}$$

$$3. \frac{a}{b} = \frac{c}{d} \Rightarrow \begin{cases} \frac{am}{b} = \frac{cm}{d}; \\ \frac{a}{bn} = \frac{c}{dn}, \end{cases} \quad m, n \neq 0.$$

(1) proporsiyadan hosilaviy proporsiyalar deb ataluvchi quyidagi proporsiyalarni hosil qilish mumkin.

$$\frac{a+b}{b} = \frac{c+d}{d} \quad (2); \quad \frac{a+b}{a} = \frac{c+d}{c} \quad (3);$$

$$\frac{a-b}{b} = \frac{c-d}{d} \quad (4); \quad \frac{a-b}{a} = \frac{c-d}{c} \quad (5);$$

$$\frac{a+b}{a-b} = \frac{c+d}{c-d} \quad (6).$$

Isbot. (2) ni isbotlaymiz $\frac{a}{b} = \frac{c}{d} \Rightarrow \frac{a}{b} + 1 = \frac{c}{d} + 1 \Rightarrow \frac{a+b}{b} = \frac{c+d}{d}$. Bu esa (2) proporsiyadan iborat.

Misol. $\frac{3+x}{3-x} = \frac{5}{6}$, $x = ?$

(6) dan foydalansak, $\frac{3+x+3-x}{3+x-3+x} = \frac{5+6}{5-6}$; $\frac{6}{2x} = \frac{11}{-1}$;

$$x = -\frac{3}{11}.$$



M a s h q l a r

2.85. Quyidagi nisbatlardan proporsiya tuzish mumkinmi:

a) $42 : 14$ va $72 : 24$; d) $3,5 : 21$ va $2\frac{1}{4} : 13\frac{1}{2}$;

b) $78 : 13$ va $60 : 12$; e) $0,1 : 0,02$ va $4 : 0,8$?

2.86. Proporsiyaning noma'lum hadini toping.

a) $x : 12 = 4\frac{3}{4} : 7\frac{1}{8}$; f) $13\frac{1}{2} : 0,4 = x : 1\frac{1}{7}$;

b) $x : 1\frac{1}{7} = 1\frac{3}{15} : 1\frac{1}{3}$; g) $10,4 : 3\frac{5}{7} = x : \frac{5}{11}$;

d) $6\frac{1}{2} : x = 6\frac{5}{6} : 4,1$; h) $15,6 : 2,88 = 2,6 : x$;

e) $0,38 : x = 4\frac{3}{4} : 1\frac{7}{8}$; i) $1,25 : 1,4 = 0,75 : x$.

2.87. Proporsiyadan x ni toping:

a) $7x : 42 = 45 : 27$; h) $4x : 31 = 44 : 11$;

b) $84 : 6x = 28 : 14$; i) $85 : 17x = 105 : 84$;

d) $21 : 7 = 2\frac{1}{2} : x$; j) $\frac{1}{6} : 2\frac{1}{3} = 3\frac{1}{4}x : 13$;

e) $13\frac{1}{3} : 1\frac{1}{3} = 26 : 0,2x$; k) $3,3 : 7\frac{1}{3}x = 4\frac{2}{7} : 1\frac{3}{7}$;

f) $3\frac{1}{3}x : 1,5 = 4\frac{2}{7} : \frac{3}{14}$; l) $3\frac{7}{19} : 1\frac{1}{2} = 2\frac{3}{8} : 0,8x$;

g) $11\frac{1}{3} : 1\frac{8}{9} = 5\frac{1}{3}x : \frac{5}{8}$; m) $6\frac{2}{3} : 1\frac{7}{9}x = 0,48 : 1,2$.

2.88. Quyidagi tengliklar yordamida proporsiyalar tuzing:

a) $15 \cdot 42 = 35 \cdot 18$; d) $2,5 \cdot 0,018 = 0,15 \cdot 0,3$;

b) $54 \cdot 55 = 66 \cdot 45$; e) $2\frac{1}{2} \cdot 1\frac{2}{7} = \frac{5}{7} \cdot 4\frac{1}{2}$.

2.89. Proporsiyadan x ni toping:

a)
$$\frac{(4 - 3,5(2\frac{1}{7} - 1\frac{1}{3})) : 0,16}{x} = \frac{3\frac{2}{7} - \frac{3}{14} : \frac{1}{6}}{41\frac{23}{84} - 40\frac{49}{60}};$$

b)
$$\frac{1,2 : 0,375 - 0,2}{6\frac{4}{25} : 15\frac{2}{5} + 0,8} = \frac{0,016 : 0,12 + 0,7}{x};$$

d)
$$\frac{0,125x}{(\frac{19}{24} - \frac{21}{40}) \cdot 8\frac{7}{16}} = \frac{(1\frac{28}{63} - \frac{17}{21}) \cdot 0,7}{0,675 \cdot 2,4 - 0,02};$$

e)
$$\frac{x}{10,5 \cdot 0,24 - 15,15 : 7,5} = \frac{9 \cdot (1\frac{11}{20} - 0,945 : 0,9)}{1\frac{3}{40} - 4\frac{3}{8} : 7}.$$

7. Protsent (foiz)lar. Turmushda ko‘p ishlatiladigan $\frac{1}{2}$, $\frac{1}{4}$, $\frac{1}{8}$ kasr sonlarning maxsus nomlari mavjud. $\frac{1}{2}$ – yarim, $\frac{1}{4}$ – chorak, $\frac{1}{8}$ – yarim chorak. Xuddi shunday kasrlardan biri $\frac{1}{100}$ dir.

Berilgan sonning bir protsenti (foizi) deb, uning yuzdan bir qismiga aytiladi va % bilan belgilanadi.

Masalan, p sonning 1% i $\frac{p}{100}$ kasrni bildiradi.

Demak, $1\% = \frac{1}{100}$, $15\% = \frac{15}{100}$, $25\% = \frac{25}{100} = \frac{1}{4}$.

Sonning $\frac{1}{1000}$ qismiga «promille» deyiladi va ‰ bilan belgilanadi. 2000 ning 5‰ si $\frac{2000}{1000} \cdot 5 = 10$, 1 ‰ = 10 ‰ -

Protsentlarga doir 4 xil masala uchraydi:

- 1) sonning protsentini topish;
- 2) protsentiga ko'ra sonni topish;
- 3) ikki sonning protsent nisbatini topish;
- 4) murakkab protsentga doir masalalar.

1- m a s a l a. a sonining $p\%$ i bo'lgan x sonini toping.

$$p\% = \frac{p}{100}, \quad x = \frac{ap}{100}.$$

Masalan, 340 ning 15% i quyidagicha topiladi:

$$x = \frac{340 \cdot 15}{100} = \frac{102}{2} = 51.$$

2- m a s a l a. Sonning $p\%$ i P ga teng. Shu sonni toping.

$$\frac{p}{100} \text{ bo'lagi } P \text{ ga teng bo'lgan } x \text{ son } x = \frac{P \cdot 100}{p} \text{ dir.}$$

Sonning 60% i 24 bo'lsa, sonning o'zi $x = \frac{24 \cdot 100}{60} = 40$.

3- m a s a l a. m soni a sonining necha protsentini tashkil etadi. Bu yerda m sonining a soniga nisbatini protsentlarda ifoda qilish kerak: $x = \frac{m}{a} \cdot 100$.

Akademik litseyda 600 nafar o'quvchi bo'lib, 120 nafari qizlar. Qizlar akademik litsey o'quvchilarining necha protsentini tashkil etadi?

$$x = \frac{120 \cdot 100}{600} = 20\%.$$

4- m a s a l a. Xalq banki mijozlarga $p\%$ foyda beradi. Mijoz xalq bankiga a so'm pul topshirsa, n yildan so'ng necha so'mga ega bo'ladi?

Y e c h i s h . Xalq bankiga a so'm qo'ygan mijoz 1 yildan so'ng

$$N_1 = a + \frac{a}{100} \cdot p = a \left(1 + \frac{p}{100} \right)$$

so'mga, 2 yildan so'ng

$$N_2 = N_1 + \frac{N_1}{100} \cdot p = a\left(1 + \frac{p}{100}\right)^2$$

so'mga, 3 yildan so'ng

$$N_3 = N_2 + \frac{N_2}{100} \cdot p = a\left(1 + \frac{p}{100}\right)^3$$

so'mga ega bo'ladi.

Shu jarayonni davom ettirib, mijoz n yildan so'ng

$$N_n = a\left(1 + \frac{p}{100}\right)^n \quad (1)$$

so'mga ega bo'lishiga ishonch hosil qilamiz. (1) tenglik odatda *murakkab protsentlar formulasi* deb ataladi.



M a s h q l a r

2.90. Kasr ko'rinishida ifodalang:

- | | | |
|-----------|----------------------|------------------------|
| a) 7%; | f) 6,8%; | j) $1\frac{1}{4}$ %; |
| b) 0,75%; | g) 0,48%; | k) $4\frac{3}{7}$ %; |
| d) 255%; | h) 29%; | l) $225\frac{3}{4}$ %; |
| e) 300%; | i) $4\frac{3}{7}$ %; | m) 0,099%. |

2.91. Protsentlarda ifodalang:

- | | | |
|----------|----------------------|-----------------------|
| a) 0,5; | f) $4\frac{3}{7}$; | j) 15,2; |
| b) 2,15; | g) $14\frac{1}{5}$; | k) $4\frac{17}{43}$; |
| d) 1,75; | h) 43; | l) $8\frac{5}{9}$; |
| e) 3; | i) 5,7; | m) 0,79. |

- 2.92.** a) 1 ning 4 ga; d) 5 ning 2 ga;
b) 3 ning 5 ga; e) 12,5 ning 50 ga;

- f) 3,2 ning 1,28 ga; h) 0,43 ning 5 ga;
g) 15 ning 18 ga; i) $\frac{1}{7}$ ning $\frac{3}{8}$ ga protsent nisbatini toping.

2.93. a ning $p\%$ va $q\%$ ini toping:

- a) $a = 75$; $p = 4$, $q = 3$;
b) $a = 84$; $p = 15$, $q = 20$;
d) $a = 330$; $p = 18\frac{1}{3}$, $q = 15$;
e) $a = 82,25$; $p = 160$, $q = 13$.

2.94. $p\%$ i a ga teng bo'lgan sonni toping:

- a) $p = 1,25$; $a = 55$; d) $p = 0,8$; $a = 1,84$;
b) $p = 40$; $a = 12$; e) $p = 15$; $a = 1,35$.

2.95. Pol sirtining 72% ini bo'yash uchun 4,5 kg bo'yoq ketdi. Polning qolgan qismini bo'yash uchun qancha bo'yoq kerak bo'ladi?

2.96. To'g'ri to'rtburchakning eni 20% uzaytirildi, bo'yi esa 20% qisqartirildi. Uning yuzi o'zgaradimi? Agar o'zgarsa, qanchaga o'zgaradi?

2.97. Ishchi ish kunida 360 ta detal tayyorladi va kunlik rejani 150% ga bajardi. Ishchi reja bo'yicha bir kunda nechta detal tayyorlashi kerak edi?

2.98. Meva quritilganda o'z og'irligining 82% ini yo'qotadi. 36 kg quritilgan meva olish uchun necha kg ho'l meva olish kerak?

2.99. 10% ga arzonlashtirilgan tovar 18 so'mga sotildi. Tovarning dastlabki narxini toping.

2.100. Shaxmat turnirida 16 o'yinchi ishtirok etdi va har bir o'yinchilar juftligi faqat bir partiya shaxmat o'ynadi. O'ynalgan partiyalarning 40% ida durang qayd etildi. Necha partiyada g'alaba qayd etilgan?

2.101. Mahsulot narxi a so'm edi. Avval uning narxi $p\%$ ga tushirildi, so'ngra $q\%$ ga oshirildi. Mahsulotning keyingi narxini toping.

- 2.102.** Uzunligi 19,8 m bo'lgan arqon ikki bo'lakka bo'lindi. Bo'laklardan birining uzunligi ikkinchisidan 20% ortiq bo'lsa, har bir bo'lakning uzunligini toping.
- 2.103.** To'g'ri to'rtburchakning katta tomoni 10% ga kamaytirilib, kichik tomoni 10% ga orttirilsa, to'g'ri to'rtburchakning yuzi qanday o'zgaradi?
- 2.104.** Xalq banki yiliga 20% foyda to'laydi. Omonatchi kassaga 15 000 so'm qo'ydi. Ikki yildan keyin uning kassadagi puli necha so'm bo'ladi?
- 2.105.** Xalq banki yiliga 30% foyda to'laydi. Omonatga qo'yilgan pul necha yildan keyin 1,69 marta ko'payadi?

8. Taqqoslamalar. a va b butun sonlarini m natural soniga bo'lishda bir xil r ($0 \leq r < m$) qoldiq hosil bo'lsa, a va b sonlari m modul bo'yicha taqqoslanadigan (teng qoldikli) sonlar deyiladi va $a \equiv b \pmod{m}$ ko'rinishda belgilanadi. a soni b soniga m modul bo'yicha taqqoslanishini ifodalovchi $a \equiv b \pmod{m}$ bog'lanish taqqoslama deb o'qiladi.

Misol. $27 = 5 \cdot 5 + 2$, $12 = 5 \cdot 2 + 2$ bo'lgani uchun $27 \equiv 12 \pmod{5}$.

1- teorema. $a \equiv b \pmod{m}$ taqqoslama $a - b$ ayirma m ga goldiqsiz bo'lingandagina o'rinli bo'ladi.

Isbot. $a \equiv b \pmod{m}$ taqqoslama o'rinli bo'lsin, ya'ni a va b sonlarini m soniga bo'lishda ayni bir xil r qoldiq hosil bo'lsin. U holda $a = mq + r$, $b = mq' + r$ tengliklar o'rinli bo'ladi, bu yerda $q, q' \in \mathbb{Z}$. Bu tengliklarni hadma-had ayirib, $a - b = mq - mq' = m(q - q')$ ga ega bo'lamiz. Demak, $a - b$ soni m ga bo'linadi.

Aksincha, $a - b$ soni m ga bo'linsin, ya'ni

$$a - b = km, k \in \mathbb{Z} \quad (1)$$

bo'lsin. b sonini m soniga qoldikli bo'lamiz:

$$b = mq + r, 0 \leq r < m. \quad (2)$$

(1) va (2) lardagi tengliklarni hadma-had qo'shib, $a = (k + q)m + r$ tenglikka ega bo'lamiz, bu yerda $0 \leq r < m$. Bundan

a sonini m soniga bo'lishdagi qoldiq b ni m soniga bo'lishdagi qoldiqqa tengligi kelib chiqadi. Demak, $a \equiv b \pmod{m}$ taqqoslama o'rinli.

2- teorema. *Har biri c soni bilan taqqoslunadigan a va b sonlari bir-biri bilan ham taqqoslanadi.*

Isbot. $a \equiv c \pmod{m}$ va $b \equiv c \pmod{m}$ bo'lsin. U holda 1- teoremaga ko'ra $a - c = mq_1$, $b - c = mq_2$ tengliklar o'rinli bo'ladi, bu yerda $q_1, q_2 \in \mathbb{Z}$. Bu tengliklardan $a - b = m(q_1 - q_2)$ ni olamiz. Demak, $a \equiv b \pmod{m}$ taqqoslama o'rinli.

3- teorema. *Moduli bir xil taqqoslamalarni hadma-had qo'shish mumkin.*

$$\text{Isbot. } \begin{cases} a_1 \equiv b_1 \pmod{m}, \\ a_2 \equiv b_2 \pmod{m}, \end{cases} \Rightarrow \begin{cases} a_1 - b_1 = mq_1, \\ a_2 - b_2 = mq_2, \end{cases} \Rightarrow$$

$$\Rightarrow (a_1 + a_2) - (b_1 + b_2) = m(q_1 + q_2) \Rightarrow a_1 + a_2 \equiv b_1 + b_2 \pmod{m}.$$

3- teoremadan qo'shiluvchini taqqoslamaning bir qismdan ikkinchi qismga qarama-qarshi ishora bilan o'tkazish mumkin ekanligi kelib chiqadi.

Haqiqatan, $a + b \equiv c \pmod{m}$ ga ayon $-b \equiv -b \pmod{m}$ taqqoslamani qo'shsak, $a \equiv c - b \pmod{m}$ hosil bo'ladi.

4- teorema. *Taqqoslamaning ixtiyoriy bir qismiga taqqoslamaning moduliga bo'linadigan har qanday butun sonni qo'shish mumkin.*

Isbot. $a \equiv b \pmod{m}$ va $mk \equiv 0 \pmod{m}$ bo'lsin. Bu taqqoslamalarni hadma-had qo'shsak, $a + mk \equiv b \pmod{m}$ hosil bo'ladi.

Masalan, $27 \equiv 12 \pmod{5} \Rightarrow 27 + 35 \equiv 12 \pmod{5} \Rightarrow 62 \equiv 12 \pmod{5}$.

5- teorema. *Bir xil modulli taqqoslamalarni hadlab ko'paytirish mumkin.*

Haqiqatan, $a \equiv b \pmod{m}$, $c \equiv d \pmod{m}$ taqqoslamalar o'rinli bo'lsa, ulardan mos ravishda $a - b = mq_1$ va $c - d = mq_2$ tengliklar kelib chiqadi. Bu tengliklar asosida $ac - bd = ac -$

$-bc + bc - bd = m(cq_1 + bq_2)$ tenglikni hosil qilamiz. Demak, $ac \equiv bd \pmod{m}$ taqqoslama o'rinli (1- teorema).

5- teoremadan taqqoslamaning har ikkala qismini bir xil natural ko'rsatkichli darajaga ko'tarish mumkinligi kelib chiqadi, ya'ni $a \equiv b \pmod{m} \Rightarrow a^n \equiv b^n \pmod{m}$.

Taqqoslamalarning amaliyotda keng qo'llaniladigan quyidagi xossalarini isbotsiz keltiramiz:

a) taqqoslamaning ikkala qismini biror butun songa ko'paytirish mumkin;

b) taqqoslamaning ikkala qismini va modulni biror natural songa ko'paytirish mumkin;

d) taqqoslamaning ikkala qismi va modulini ularning umumiy bo'luvchilariga bo'lish mumkin;

e) agar a va b sonlari m_1, m_2, \dots, m_n modullar bo'yicha taqqoslansa, u holda ular $K(m_1, m_2, \dots, m_n)$ modul bo'yicha ham taqqoslanadi;

f) agar d soni m ning bo'luvchisi bo'lib, $a \equiv b \pmod{m}$ bo'lsa, u holda $a \equiv b \pmod{d}$ bo'ladi.

1- misol. 3^{30} ni 8 ga bo'lishdan chiqadigan qoldiqni topamiz.

Yechish. $3^2 = (9 - 8) \pmod{8} \Rightarrow (3^2)^{15} = 1^{15} \pmod{8} \Rightarrow 3^{30} \equiv 1 \pmod{8} \Rightarrow 3^{30} = 8q + 1$. Demak, izlanayotgan qoldiq $r = 1$.

2- misol. $\Sigma = 30^{n+2} + 23^{n+1} + 9^n$ ($n \in \mathbb{N}$) sonining 7 ga bo'linishini isbot qiling.

$$\text{Yechish. } \begin{cases} 30 \equiv 2 \pmod{7}, \\ 23 \equiv 2 \pmod{7}, \\ 9 \equiv 2 \pmod{7} \end{cases} \Rightarrow \begin{cases} 30^{n+2} \equiv 2^{n+2} \pmod{7}, \\ 23^{n+1} \equiv 2^{n+1} \pmod{7}, \\ 9^n \equiv 2^n \pmod{7}, \end{cases} \Rightarrow$$

$$\Rightarrow 30^{n+2} + 23^{n+1} + 9^n \equiv 2^{n+2} + 2^{n+1} + 2^n \pmod{7} \Rightarrow \Sigma \equiv 2^n(2^2 + 2^1 + 2^0) \pmod{7} \Rightarrow (\Sigma \text{ yig'indi } 7 \text{ ga bo'linadi}).$$

3- misol. 2222^{5555} sonini 7 ga bo'lishda hosil bo'ladigan qoldiqni toping.

Y e c h i s h. 2222 ni 7 ga qoldiqli bo'lamiz: $2222 = 7 \cdot 317 + 3$. Bundan $2222 \equiv 3 \pmod{7}$ ni olamiz. Hosil bo'lgan taqqoslamaning har ikki tomonini 5555- darajaga ko'taramiz: $2222^{5555} \equiv 3^{5555} \pmod{7}$.

Bu taqqoslama izlanayotgan qoldiq 3^{5555} ni 7 ga bo'lishdan hosil bo'ladigan qoldiq bilan bir xil ekanligini ko'rsatadi. 3^{5555} ni 7 ga bo'lishda hosil bo'ladigan qoldiqni topamiz. Buning uchun 3 ning dastlabki bir nechta darajalarini 7 ga bo'lishda qanday qoldiqlar hosil bo'lishini kuzataylik:

$3^1 \equiv 3 \pmod{7}$; $3^2 \equiv 3 \cdot 3 \equiv 9 \equiv 2 \pmod{7}$; $3^3 \equiv 2 \cdot 3 \equiv 6 \pmod{7}$;
 $3^4 \equiv 6 \cdot 3 \equiv 18 \equiv 4 \pmod{7}$; $3^5 \equiv 4 \cdot 3 \equiv 12 \equiv 5 \pmod{7}$; $3^6 \equiv 5 \cdot 3 \equiv 15 \equiv 1 \pmod{7}$; $3^6 \equiv 1 \pmod{7}$ ga ega bo'ldik. Bundan $3^{6k} \equiv 1^k \pmod{7}$, $k \in N$ (2) ni olamiz.

Endi 5555 ni 6 ga bo'lamiz: $5555 = 6 \cdot 925 + 5$.

U holda $3^{5555} = 3^{6 \cdot 925 + 5} = 3^{6 \cdot 925} \cdot 3^5 \equiv 1 \cdot 3^5 \equiv 5 \pmod{7}$.

Shunday qilib, izlanayotgan qoldiq 5 ga teng.

4- m i s o l. $2^{60} + 7^{30}$ soni 13 ga bo'linadi. Isbotlang.

I s b o t. $2^4 = 13 + 3$ va $7^2 = 49 = 13 \cdot 4 - 3$ bo'lgani uchun $2^4 \equiv 3 \pmod{13}$, $7^2 \equiv -3 \pmod{13}$ larga egamiz. Oxirgi har bir taqqoslamaning 15- darajaga ko'tarib, ularni hadma-had qo'shamiz: $2^{60} + 7^{30} \equiv 0 \pmod{13}$.

Demak, $2^{60} + 7^{30}$ soni 13 ga bo'linadi.

5- m i s o l. 7^{77} ning oxirgi raqamini toping.

Y e c h i s h. 7 ning dastlabki bir nechta darajalarining oxirgi raqamini kuzatamiz:

$$7^1 = 7 \qquad 7^5 = *7$$

$$7^2 = 49 \qquad 7^6 = *9$$

$$7^3 = *3 \qquad 7^7 = *3$$

$$7^4 = *1 \qquad 7^8 = *1$$

Takrorlanish sodir bo'ldi (qadam 4 ga teng). Kuzatuv quyidagi xulosani chiqarishga imkon beradi:

$$7^n = \begin{cases} *7, & \text{agar } n \equiv 1(\text{mod } 4) \\ *9, & \text{agar } n \equiv 2(\text{mod } 4) \\ *3, & \text{agar } n \equiv 3(\text{mod } 4) \\ *1, & \text{agar } n \equiv 0(\text{mod } 4) \end{cases} \quad (3)$$

Endi $n = 7^{77}$ ni 4 ga bo'lishda hosil bo'ladigan qoldiqni aniqlaymiz:

$$7^1 \equiv 3 \pmod{4}; \quad 7^2 \equiv 3 \cdot 7 \equiv 1 \pmod{4}; \quad 7^{2k} \equiv 1 \pmod{4}; \\ 7^{77} \equiv 7^{2 \cdot 38 + 1} \equiv 7^{2 \cdot 38} \cdot 7 \equiv 1 \cdot 7 \equiv 3 \pmod{4}.$$

$7^{77} \equiv 3 \pmod{4}$ bo'lgani uchun, (3) ga asosan $7^{77} = *3$.
Shunday qilib, oxirgi raqam 3 ekan.

6- misol. Ixtiyoriy n natural son uchun $n^5 - n$ soni 5 ga bo'linishini isbotlang.

I s b o t. n — ixtiyoriy natural son bo'lsin. n ni 5 ga bo'lamiz.

Agar $n \equiv 0 \pmod{5}$ bo'lsa, $n^5 - n \equiv 0^5 - 0 \equiv 0 \pmod{5}$ bo'ladi.

Agar $n \equiv 1 \pmod{5}$ bo'lsa, $n^5 - n \equiv 1^5 - 1 \equiv 0 \pmod{5}$ bo'ladi.

Agar $n \equiv 2 \pmod{5}$ bo'lsa, $n^5 - n \equiv 2^5 - 2 \equiv 30 \equiv 0 \pmod{5}$ bo'ladi.

Agar $n \equiv 3 \pmod{5}$ bo'lsa, $n^5 - n \equiv 3^5 - 3 \equiv 240 \equiv 0 \pmod{5}$ bo'ladi.

Agar $n \equiv 4 \pmod{5}$ bo'lsa, $n^5 - n \equiv 4^5 - 4 \equiv 1020 \equiv 0 \pmod{5}$ bo'ladi.

n ning har qanday qiymatida, $n^5 - n \equiv 0 \pmod{5}$ ekanini ko'ramiz. Demak, $\forall n \in \mathbb{N}$ uchun $n^5 - n$ soni 5 ga qoldiqsiz bo'linadi.



M a s h q l a r

2.106. a ni b ga qoldiqli bo'ling:

a) $a = 70, b = 3;$

d) $a = 200, b = 17;$

b) $a = 180, b = 9;$

e) $a = 76, b = 9.$

2.107. a ni b ga qoldiqli bo'ling:

a) $a = 5, b = 9$;

d) $a = 9, b = 18$;

b) $a = 11, b = 23$;

e) $a = 4, b = 75$.

2.108. a ni b ga qoldiqli bo'ling:

a) $a = -81, b = 75$;

h) $a = -6, b = 48$;

b) $a = -5, b = 9$;

i) $a = -8, b = 24$;

d) $a = -41, b = 7$;

j) $a = 15, b = 43$;

e) $a = -35, b = 7$;

k) $a = 27, b = 9$;

f) $a = -33, b = 7$;

l) $a = 33, b = 32$;

g) $a = -48, b = 6$;

m) $a = 108, b = 36$.

2.109. $a \in \mathbb{N}, b \in \mathbb{N}$ bo'lib, $a = bq + r$ ($q \in \mathbb{Z}, r \in \mathbb{N}, 0 \leq r < b$) bo'lsin. $-a$ ni b ga bo'lishda hosil bo'ladigan to'liqsiz bo'linma q_1 ni va qoldiq r_1 ni toping.

2.110. a ni b ga bo'lishdagi qoldiqni toping:

a) $a = 81\ 932, b = 9$;

h) $a = -15, b = 11$;

b) $a = 25, b = 75$;

i) $a = -13, b = 35$;

d) $a = -4, b = 49$;

j) $a = 111, b = 11$;

e) $a = -49, b = 4$;

k) $a = -11, b = 111$;

f) $a = 4\ 341, b = 3$;

l) $a = -9, b = 3$;

g) $a = 144, b = 6$;

m) $a = -3, b = 9$.

2.111. Quyidagi tenglik qoldiqli bo'lishni ifodalaydimi:

a) $21 = 3 \cdot 4 + 9$;

h) $-49 = 7 \cdot 8 + (-7)$;

b) $-18 = 9 \cdot 2 - 36$;

i) $84 = 2 \cdot 42$;

d) $35 = 2 \cdot 17 + 1$;

j) $81 = 81 \cdot 0 + 81$;

e) $11 = 2 \cdot 4 + 3$;

k) $-40 = 4 \cdot (-11) + 4$;

f) $26 = 4 \cdot 5 + 6$;

l) $-35 = (-7) \cdot 8 + 21$;

g) $-15 = 11 \cdot (-2) + 7$;

m) $49 = 4 \cdot 11 + 5$?

2.112. Taqqoslama to'g'rimi:

a) $125 \equiv -35 \pmod{4}$;

f) $113 \equiv 13 \pmod{100}$;

b) $44 \equiv -32 \pmod{25}$;

g) $842 \equiv 42 \pmod{-5}$;

d) $-58 \equiv 11 \pmod{5}$;

h) $31 \equiv -20 \pmod{17}$;

e) $111 \equiv 13 \pmod{}$;

i) $1 \equiv 18 \pmod{0}$?

2.113. $n \in \{3, 5, 9\}$ bo'lsin. n ning qaysi qiymatlarida taqqoslama to'g'ri bo'ladi:

- a) $33 \equiv 3 \pmod{n}$; f) $43 \equiv -2 \pmod{n}$;
b) $134 \equiv -25 \pmod{n}$; g) $-121 \equiv 13 \pmod{n}$;
d) $-223 \equiv 41 \pmod{n}$; h) $155 \equiv 11 \pmod{n}$;
e) $34 \equiv 72 \pmod{n}$; i) $-48 \equiv 11 \pmod{n}$?

2.114. 5^{20} ni 24 ga bo'lishda hosil bo'ladigan qoldiqni toping.

2.115. 3333^{6666} ni 5 ga bo'lishda hosil bo'ladigan qoldiqni toping.

2.116. Sonning oxirgi raqamini toping.

- a) $8^{8^{87}}$; f) $555^{222^{22}}$; j) 10001^{9n} , $n \in \mathbb{Z}$;
b) $113^{8^{91}}$; g) $333^{444^{555}}$; k) 1005^{1005n} , $n \in \mathbb{Z}$;
d) $144^{5^{555}}$; h) $1111^{9^{99}}$; l) $8^{8^{95}}$;
e) $2002^{9^{95}}$; i) $999^{2^{888^{999}}}$; m) $6^{7^{89}}$.

2.117. n ning barcha butun qiymatlarida $(n^3 + 11n)$ soni 6 ga qoldiqsiz bo'linishini isbotlang.

2.118. n ning barcha butun qiymatlarida $(n^3 - n)$ 3 ga qoldiqsiz bo'linishini isbotlang.

2.119. $n^2 + 1$ soni n ning ixtiyoriy butun qiymatida 3 ga bo'linmasligini isbotlang.

2.120. $(3299^5 + 6^{18})$ sonining 56 ga bo'linishini isbotlang.

2.121. $12^{2n+1} + 11^{2n+2}$ soni n ning har qanday natural qiymatida 133 ga bo'linishini isbotlang.

2.122. p soni 3 dan katta tub son bo'lsa, $p^2 - 1$ soni 24 ga bo'linadi. Isbotlang.

2.123. p va q sonlari 3 dan katta tub sonlar bo'lsa, $p^2 - q^2$ soni 24 ga bo'linadi. Isbotlang.

4- §. Koordinatalar o'qi va koordinatalar tekisligi

1. Yo'naltirilgan kesma, to'g'ri chiziqdagi koordinatalar. Biror l to'g'ri chiziqda yo'nalish kiritib, uni *musbat yo'nalish*, teskarisini esa *manfiy yo'nalish* sifatida qabul qilaylik (10- rasm).

Yo'naltirilgan \vec{l} to'g'ri chiziqda O, A, B, \dots nuqtalarni belgilaymiz. A va B nuqtalar hosil qilgan kesmaning bir uchini uning boshi, ikkinchi uchini esa uning oxiri sifatida qabul qilib, yo'naltirilgan (yo'nalishga ega bo'lgan) kesmani hosil qilamiz. Boshi

A , oxiri esa B bo'lgan yo'naltirilgan kesmani \vec{AB} bilan belgilaymiz.

U holda \vec{AB} va \vec{BA} kesmalar qarama-qarshi yo'naltirilgan

kesmalar bo'ladi: $\vec{AB} = -\vec{BA}$. Agar \vec{AB} kesmaning yo'nalishi l to'g'ri chiziq yo'nalishi bilan bir xil bo'lsa, uni musbat yo'naltirilgan, aks holda esa manfiy yo'naltirilgan kesma deb ataymiz.

Yo'naltirilgan \vec{l} to'g'ri chiziqda koordinatalar boshi sifatida biror O nuqtani (10- rasm) va uzunlik o'lchov birligini tanlaylik.

Yo'naltirilgan \vec{AB} kesmaning *kattaligi* deb moduli shu kesmaning

uzunligiga teng AB songa aytiladi; agar \vec{AB} ning yo'nalishi \vec{l} ning

yo'nalishi bilan bir xil bo'lsa, $AB > 0$, aks holda $AB < 0$ bo'ladi.

Boshi va oxiri ustma-ust tushgan kesmaning uzunligi nolga teng bo'ladi. 10- rasmda $AB = 3$, $BA = -3$, $BC = 6$, $CA = -9$ tasvirlangan.

Unda $AB + BC + CA = 0$ bo'lishini ko'ramiz. Bu mulohaza A_1, \dots, A_n nuqtalarning ixtiyoriy chekli to'plami uchun o'rinli bo'lishi



10- rasm.

tushunarli. OA kesmaning kattaligi A nuqtaning *koordinatasi* deyiladi va $A(x)$ ko'rinishida yoziladi, \vec{l} to'g'ri chiziq *koordinatalar to'g'ri chizig'i* (*o'qi*) deyiladi.

Sonlar o'qida har bitta nuqtaga bitta aniq son mos keladi va aksincha. $\forall a, b \in \mathbb{R}$ sonlari uchun quyidagi munosabatlardan bittasi albatta bajariladi: $a = b$; $a > b$; $a < b$.

T a' r i f. $a > b$, $a < b$ munosabatlarga sonli tengsizlik deyiladi. Sonli tengsizliklar quyidagi xossalarga ega:

1. Agar $a > b$ bo'lsa, u holda $b < a$ bo'ladi.
2. Agar $a > b$ va $b > c$ bo'lsa, u holda $a > c$ bo'ladi.
3. Agar $a > b$ bo'lsa, $\forall c \in \mathbb{R}$ uchun $a \pm c > b \pm c$ bo'ladi.
4. Agar $a > b$ bo'lsa, $\forall c > 0$ uchun $ac > bc$ va $\frac{a}{c} > \frac{b}{c}$ bo'ladi.
5. Agar $a < b$ bo'lsa, $\forall c < 0$ uchun $ac > bc$ va $\frac{a}{c} > \frac{b}{c}$ bo'ladi.

$a > b$ va $c > d$ yoki $a < b$ va $c < d$ tengsizliklar *bir xil ma'noli tengsizliklar* deyiladi.

6. $a > b$ va $c > d$ bo'lsa, $a + c > b + d$ bo'ladi.
7. $a > b$ va $c < d$ bo'lsa, $a - c > b - d$ bo'ladi.
8. $a > 0$, $b > 0$, $c > 0$, $d > 0$ bo'lib, $a > b$ va $c > d$ bo'lsa, $ac > bd$ bo'ladi.

9. $a > 0$, $b > 0$, $c > 0$, $d > 0$ bo'lib, $a > b$ va $c < d$ bo'lsa, $\frac{a}{c} > \frac{b}{d}$ bo'ladi.

10. $a > 0$, $b > 0$, $a < b$ bo'lsa, $n \in \mathbb{N}$ uchun $a^n < b^n$ bo'ladi.

11. $a > 0$, $b > 0$ uchun $a < b$ bo'lsa, $\frac{1}{a} > \frac{1}{b}$ bo'ladi.

$a > b$, $c < d$ tengsizliklar *qat'iy tengsizliklar*, $a \geq b$, $c \leq d$ tengsizliklar esa *noqat'iy tengsizliklar* deyiladi.

4- xossani isbotlaymiz:

$c > 0$ va $a - b > 0$ bo'lganligi uchun $c(a - b) = ac - bc > 0$ bo'ladi. Demak, $ac > bc$.

Son o'qida x o'zgaruvchi turli oraliqlarda joylashgan bo'lishi mumkin, bu oraliqlar *sonli oraliqlar* deyiladi. Sonli oraliqlar aniq bir sonli to'plamni aniqlaydi. Sonli oraliqlar $a < x < b$ yoki

boshqa ko'rinishdagi tengsizliklarning geometrik talqinidan iborat.

Quyidagi jadvalda eng ko'p qo'llaniladigan sonli oraliqlar berilgan.

No	Oraliq nomi	Tengsizlik shaklida yozilishi	Simvolik belgilanishi	Geometrik talqini
1	«a» dan «b» gacha yopiq oraliq	$a \leq x \leq b$	$[a, b]$	
2	«a» dan «b» gacha ochiq oraliq	$a < x < b$	(a, b)	
3	«a» dan «b» gacha yarim ochiq oraliq	$a < x \leq b$	$(a, b]$	
4	«a» dan «b» gacha yarim ochiq oraliq	$a \leq x < b$	$[a, b)$	
5	«a» dan $+\infty$ gacha sonli nur	$x \geq a$ ($a \leq x$) $(a \leq x < +\infty)$	$[a, +\infty)$	
6	«a» dan $+\infty$ gacha ochiq oraliq	$x > a$ ($a < x$) $(a < x < +\infty)$	$(a, +\infty)$	
7	$-\infty$ dan «a» gacha sonli nur	$x \leq a$ ($a \geq x$) $(-\infty < x \leq a)$	$(-\infty, a]$	
8	$-\infty$ dan «a» gacha ochiq oraliq	$x < a$ ($a > x$) $(-\infty < x < a)$	$(-\infty, a)$	
9	Son o'qi	$-\infty < x < +\infty$	$(-\infty, +\infty)$	

1- misol. Koordinatalar to'g'ri chizig'ida $E(x_1)$ va $F(x_2)$ nuqtalar orasidagi masofani topamiz.

Yechish. Chizmaga qaraganda (10- rasm) $OE + EF + FO = 0$, bundan $EF = -FO - OE = OF - OE = x_2 - x_1$. Demak, $|EF| = |x_2 - x_1|$.

2- misol. Koordinatalar to'g'ri chizig'ida (10- rasm). $B(8)$ nuqtadan 6 birlik uzoqlikda joylashgan nuqtalarni topamiz.

Yechish. Izlanayotgan nuqtaning koordinatasi x bo'lsin. Uni topamiz:

$$|x - 8| = 6 \Leftrightarrow \begin{cases} x - 8 > 0, \\ x - 8 = 6; \\ x - 8 < 0, \\ -x + 8 = 6 \end{cases} \Leftrightarrow \begin{cases} x > 8, \\ x = 14; \\ x < 8, \\ x = 2 \end{cases} \Leftrightarrow \begin{cases} x = 14, \\ x = 2. \end{cases}$$

Javob: $K(2)$, $C(14)$.

3- misol. Koordinatalar to'g'ri chizig'ida ushbu tengsizliklar yechimini tasvirlaymiz: a) $|x - 8| \leq 6$; b) $|x - 8| > 6$.

Yechish. a) $|x - 8|$ soni $N(x)$ nuqtadan (10- rasm) $B(8)$ nuqtagacha masofaga teng va 6 dan ortiq emas. Shunga ko'ra: $|x - 8| \leq 6 \Leftrightarrow -6 \leq x - 8 \leq 6$ yoki $2 \leq x \leq 14$. Izlanayotgan nuqtalar to'plami $K(2)$ va $C(14)$ nuqtalar orasidagi KC kesmadan iborat; b) koordinatalar to'g'ri chizig'ining $[2; 14]$ kesmadan tashqaridagi qismi javobni beradi: $(-\infty; 2) \cup (14; +\infty)$.

4- misol. Uchlari $A(x_1)$, $B(x_2)$ nuqtalarda bo'lgan AB kesmani $AM : MB = \lambda : 1$ nisbatda bo'luvchi $M(x)$ nuqtani topamiz.

Yechish.
$$\frac{AM}{MB} = \frac{\lambda}{1} \Leftrightarrow \frac{x - x_1}{x_2 - x} = \frac{\lambda}{1} \Leftrightarrow x = \frac{x_1 + \lambda x_2}{1 + \lambda}. \quad (1)$$

Agar (1) da $\lambda = 1$ desak, AB kesma o'rtasining koordinatasi:

$x = \frac{x_1 + x_2}{2}$ hosil bo'ladi. Shuningdek, (1) formulaga $\lambda = m_2 : m_1$ ni qo'yib, AB kesmani $m_2 : m_1$ nisbatda bo'luvchi nuqta koordinatasini hosil qilish mumkin:

$$x = \frac{m_1 x_1 + m_2 x_2}{m_1 + m_2}.$$

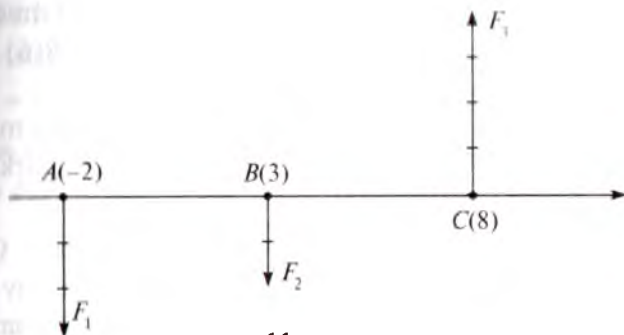

11- rasm.

Umuman, m_1, m_2, \dots, m_n massalar mos tartibda $A_1(x_1), \dots, A_n(x_n)$ nuqtalarga qo'yilgan bo'lsa, bu massalar $M(x)$ markazining koordinatasi

$$x = \frac{m_1 x_1 + \dots + m_n x_n}{m_1 + \dots + m_n} \quad (2)$$

bo'ladi.

5- misol. 2, 4, 6, 8 ga teng massalar mos tartibda $A(2), B(9), C(-6), D(3)$ nuqtalarga joylashtirilgan. Massalar markazini topamiz.

Yechish. (2) formula bo'yicha:

$$x = \frac{2 \cdot 2 + 4 \cdot 9 + 6 \cdot (-6) + 8 \cdot 3}{2 + 4 + 6 + 8} = 1,4.$$

6- misol. Koordinatalar to'g'ri chizig'ining A, B, C nuqtalariga (11- rasm) tik qo'yilgan F_1, F_2, F_3 kuchlar teng ta'sir etuvchisi qo'yilgan nuqta koordinatasini topamiz.

Yechish. Chizmada $A(-2), B(3), C(8), F_1 = -3, F_2 = -2, F_3 = 4$. (4) formula bo'yicha:

$$x = \frac{(-3) \cdot (-2) + (-2) \cdot 3 + 4 \cdot 8}{-3 - 2 + 4} = -32.$$



Mashqlar

2.124. To'plamlarni koordinatalar to'g'ri chizig'ida tasvirlang:

a) $A = \{x | -5 \leq x \leq 20\}$;

d) $C = \{x | |x + 1| < 5\}$.

b) $B = \{x | -4 \leq x \leq 6\}$;

2.125. a) Koordinatalar to'g'ri chizig'ida shunday nuqtalarni topingki, ulardan $A(-4)$ gacha masofa $B(6)$ gacha masofadan 4 marta katta bo'lsin.

b) $A(2)$, $B(4)$, $C(5)$, $D(9)$ moddiy nuqtalarning massalari mos tartibda 3, 5, 7, 9 ga teng. Massalar markazining koordinatasini toping.

2.126. a) $A(-3)$ va $B(6)$ nuqtalarda 4 C (kulon) va 2 C elektr zaryadi joylashtirilgan. Koordinatalar o'qida shunday nuqtani topingki, unda bu zaryadlar tortishish kuchlarining teng ta'sir etuvchisi nolga teng bo'lsin.

b) $A(-4)$ va $B(2)$ nuqtalarda mos tartibda 2 C va 1 C zaryad joylashtirilgan. Son o'qining qaysi nuqtasida bu zaryadlar ta'siri tenglashadi?

2. Koordinata tekisligi. Tekislikning belgilangan O nuqtasi (sanoq boshi) orqali o'zaro perpendikular bo'lgan Ox (absissalar) va Oy (ordinatalar) o'qlarini o'tkazamiz. O nuqta bu ikkala o'q bo'yicha ham 0 (nol) koordinataga ega: $O(0; 0)$. O nuqtadan musbat va manfiy yo'nalishlar boshlanadi. Tekislikdagi har qanday M nuqta bitta $(x; y)$ koordinatalar juftiga ega bo'ladi (12- a rasm). Tekislikda koordinatalar sistemasining kiritilishi ko'pgina geometrik masalalarni algebraik usulda yechish imkonini beradi.

1- misol. Tekislikning $M(x_1; y_1)$ va $N(x_2; y_2)$ nuqtalari orasidagi MN masofani toping (12- b rasm).

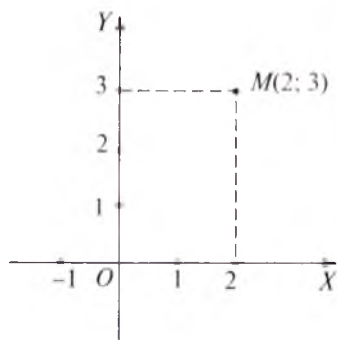

a)

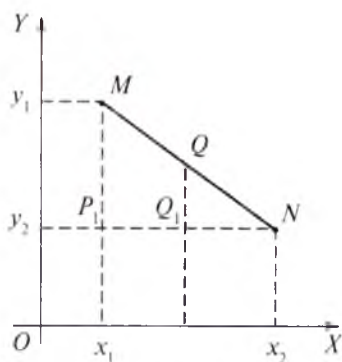

b)

12- rasm.

Y e c h i s h. Agar $x_1 = x_2$ bo'lsa, MN kesma MP kesma bilan ustma-ust joylashgan bo'ladi va $MN = |y_2 - y_1|$ bo'lishi ayon. Shu kabi $y_1 = y_2$ da $MN = |x_2 - x_1|$ bo'ladi.

$x_1 \neq x_2$, $y_1 \neq y_2$ bo'lsin. Pifagor teoremasiga muvofiq $MN^2 = PN^2 + MP^2 = (x_2 - x_1)^2 + (y_2 - y_1)^2$. Demak,

$$MN = \sqrt{(x_2 - x_1)^2 + (y_2 - y_1)^2}. \quad (1)$$

2- m i s o l. Tekislikda yotgan $M(x_1; y_1)$ va $N(x_2; y_2)$ nuqtalar orasidagi masofani $\lambda : 1$, $\lambda > 0$ nisbatda bo'luvchi $Q(x; y)$ nuqtani toping (12- b rasm).

Y e c h i s h. Uchburchaklarning o'xshashligiga ko'ra $P_1Q_1 : Q_1N = MQ : QN = \lambda : 1$, bundan va 1- banddagi (2) formula bo'yicha:

$$x = \frac{x_1 + \lambda x_2}{1 + \lambda}, \quad y = \frac{y_1 + \lambda y_2}{1 + \lambda}.$$

Bu formulalar $\lambda \leq 0$, $\alpha \neq -1$ da ham o'rinni.

3- m i s o l. 13- rasmda tasvirlangan bir jinsli plastinkaning massalar markazini toping.

Y e c h i s h. Plastinkani ikki to'rtburchakka ajratamiz. Bir jinsli bo'lganidan plastinka yuzini massasiga mutanosib (koeffitsiyentini esa 1 ga teng) deb olamiz. U holda to'rtburchaklar massalari markazi diagonallari kesishgan nuqtada, yuzalari esa $S_1 = m_1 = 2 \cdot 10 = 20$, $S_2 = 2 \cdot 4 = 8$ bo'ladi. 1- banddagi (2) formulalar bo'yicha:

$$x = \frac{20 \cdot 1 + 8 \cdot 3}{20 + 8} = 1 \frac{4}{7},$$

$$y = \frac{20 \cdot 5 + 8 \cdot 8}{20 + 8} = 5 \frac{6}{7}.$$

Demak, massalar markazi $(1 \frac{4}{7}; 5 \frac{6}{7})$ nuqtadan iborat.

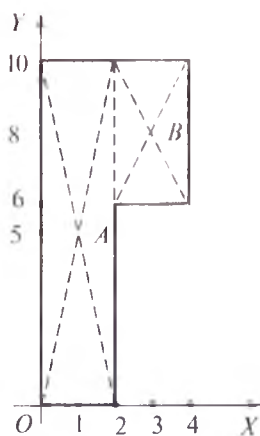

13- rasm.



Mashqlar

- 2.127. a) Ordinatalar o'qida $A(1; -3)$ nuqtadan 4 birlik uzoqlikdagi Y nuqtani toping;
b) ABC uchburchak berilgan, $A(-5; -3)$, $B(6; 2)$, $C(3; -1)$. BC va AC tomonlarining o'rtalarini tutashtiruvchi kesmaning uzunligini toping;
d) trapetsiyaning uchlari $A(-3; 2)$, $B(8; 2)$, $C(6; 5)$, $D(-1; 5)$ nuqtalarda yotadi. Trapetsiya o'rta chizig'ining uzunligini toping;
e) uchburchakning uchlari: $A(0; -2)$, $B(3; 0)$, $C(-1; 4)$. Uning: 1) medianalari kesishgan N nuqtani; 2) AB tomonining A uchidan boshlab $3:1$ nisbatda bo'luvchi M nuqtani toping; 3) MN to'g'ri chiziq kesmasining uzunligini toping.
- 2.128. Agar $A(-4; -3)$, $B(-4; 4)$, $O(0; 0)$ bo'lsa, AOB uchburchakning AK bissektrisasi bilan BC tomonining kesishuv nuqtasini toping.
- 2.129. a) 14- rasmda tasvirlangan sterjenlar sistemasining;
b) 15- rasmda tasvirlangan shakldagi bir jinsli plastinkaning massalar markazini toping.
- 2.130. a) Yig'uvchi linza uchun $\frac{1}{F} = \frac{1}{d} + \frac{1}{f}$ tenglik o'rinli, bunda $F = 2$ m – linzaning fokus oralig'i, d va f – linzadan

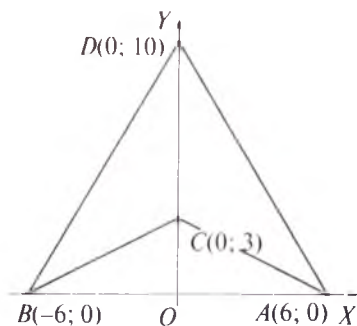

14- rasm.

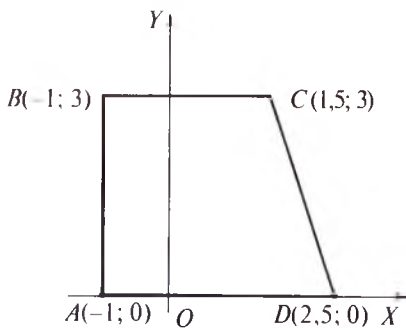

15- rasm.

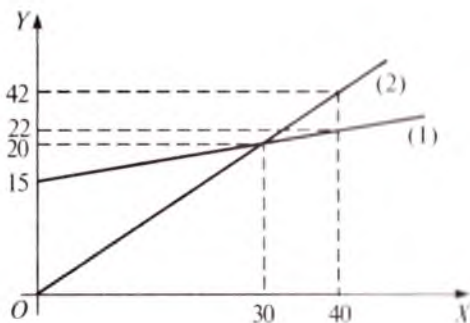

16- rasm.

buyumgacha va uning tasvirigacha masofalar; linza $A(6; 3)$ nuqtada, buyum $B(2; 0)$ nuqtada joylashtirilgan. Tasvirning koordinatalarini toping.

b) Absissalar o'qida (16- rasm) korxonada ishlab chiqarotgan buyumlar miqdori (tonnalarda), ordinatalar o'qida xarajat va daromad (o'n ming so'mlarda), (1) to'g'ri chiziq mahsulotni ishlab chiqarish uchun xarajat, (2) to'g'ri chiziq mahsulotni sotishdan olinadigan daromadni tasvirlaydi. Savollarga javob bering: 1) korxonada ishlab chiqarish boshlanguncha ($x=0$ holi) qancha xarajat bo'lgan? 2) ishlab chiqarilgan mahsulotdan qanchasi sotilgandan keyin dastlabki xarajatlar qoplangan va korxonada sof foyda olish boshlagan?

d) 25 t mahsulotni tayyorlashga qancha mablag' sarf bo'ladi, sotishdan qancha foyda olinadi, sof foyda qancha bo'ladi?

5- §. Induksiya. Matematik induksiya metodi

1. Induksiya. X to'plam berilgan bo'lsin. Mulohaza yuritishning quyidagi ikki usulini qaraymiz:

a) biror tasdiq ba'zi $x \in X$ elementlar uchun to'g'ri bo'lsa, bu tasdiq barcha $x \in X$ lar uchun to'g'ri bo'ladi;

b) biror tasdiq har bir $x \in X$ elementlar uchun o'rinli bo'lsa, bu tasdiq barcha $x \in X$ lar uchun o'rinli bo'ladi.

Mulohaza yuritishning a) *usuli to'liqmas induksiya*; b) *usuli esa to'liq (mukammal) induksiya* deyiladi («induksiya» so'zi lotincha so'z bo'lib, o'zbek tilida «hosil qilish», «yaratish» ma'nosini bildiradi).

1- misol. $N = \{1; 2; 3; 4; \dots\}$ natural sonlar to'plamida aniqlangan $A(n) = n^2 + n + 17$ ifodani qaraymiz. $A(1) = 19$, $A(2) = 23$, $A(3) = 29$ va $A(4) = 37$ sonlari tub sonlardir. Shuning uchun, barcha $n \in N$ sonlari uchun $A(n) = n^2 + n + 17$ ifodaning qiymati tub son bo'ladi.

Bu yerda to'liqmas induksiya yordamida xulosa chiqarildi. Chiqarilgan bu xulosa noto'g'ridir, chunki $A(16) = 289 = 17^2$ soni tub son emas.

2- misol. $X = \{10; 20; 30; 40; 50; \dots\}$ to'plam yozuvi 0 raqami bilan tugaydigan barcha natural sonlar to'plami bo'lsin. 10; 20; 30; 40; 50 sonlarining har biri 2 ga qoldiqsiz bo'linadi. Shuning uchun X to'plamning har qanday x elementi 2 ga bo'linadi. To'liqmas induksiya yordamida chiqarilgan bu xulosa to'g'ri xulosadir, chunki X to'plamning har qanday elementi juft sonidir.

3- misol. $N = \{1; 2; 3; \dots; 1\,000\,000\,001; \dots\}$ natural sonlar to'plamida aniqlangan $B(n) = 991n^2 + 1$ ifodani qaraymiz. $B(1)$, $B(2)$, ..., $B(1\,000\,000\,001)$ sonlari butun sonning kvadrati emas (bu tasdiq isbotlangan!). Shuning uchun, barcha $n \in N$ lar uchun $B(n)$ soni butun sonning kvadrati bo'la olmaydi.

To'liqmas induksiya yordamida chiqarilgan bu xulosa noto'g'ridir. Zamonaviy hisoblash mashinalari yordamida n ning $B(n)$ soni butun sonning kvadrati bo'ladigan qiymati aniqlangan (bu qiymat 29 xonali sondan iborat).

To'liqmas induksiya ba'zan noto'g'ri xulosaga olib kelsa-da (1- misol, 3- misol), uning matematikadagi va boshqa fanlar (fizika, kimyo, biologiya va h.k.)dagi, shuningdek, amaliyotdagi ahamiyati juda kattadir. U xususiy xulosalar yordamida umumiy xulosa (faraz, taxmin) qilish imkonini beradi.

To'liq induksiya hamma vaqt to'g'ri xulosaga olib keladi, lekin uni qo'llashda hisoblash ishlariga yoki to'plamdagi elementlar soniga bog'liq bo'lgan ba'zi qiyinchiliklar paydo bo'ladi.

4- m i s o l. $X = \{1; 2; 3; 4\}$ to'plamni qaraymiz.

$C(x) = (x-1)(x-2)(x-3)(x-4)(x-5)(x-6)(x-7)(x-8)(x-9)$ ifoda har bir $x \in X$ da nolga teng qiymat qabul qiladi:

$$C(1) = (1-1)(1-2)(1-3)(1-4)(1-5)(1-6)(1-7)(1-8)(1-9) = 0;$$

$$C(2) = (2-1)(2-2)(2-3)(2-4)(2-5)(2-6)(2-7)(2-8)(2-9) = 0;$$

$$C(3) = (3-1)(3-2)(3-3)(3-4)(3-5)(3-6)(3-7)(3-8)(3-9) = 0;$$

$$C(4) = (4-1)(4-2)(4-3)(4-4)(4-5)(4-6)(4-7)(4-8)(4-9) = 0.$$

Demak, barcha $x \in X$ lar uchun, $C(x) = 0$ tenglik o'rinli.

Agar X to'plam cheksiz to'plam bo'lsa yoki undagi elementlar soni juda katta bo'lsa, to'plamning har bir elementi uchun berilgan tasdiqning to'g'ri ekanligini ko'rsatish mumkin bo'lmaydi yoki juda qiyin bo'ladi. Shu sababli to'liq induksiyadan juda kam hollarda foydalaniladi.

5- m i s o l. To'liqmas induksiyadan foydalanib, «Agar m xonali $N = a_1 \cdot 10^{m-1} + a_2 \cdot 10^{m-2} + \dots + a_{m-1} \cdot 10 + a_m$ sonining oxirgi n ta (bu yerda $n \leq m$) raqamidan tuzilgan son 5^n ga bo'linsa, N soni ham 5^n ga bo'linadi» degan farazni aytish mumkinmi?

Y e c h i s h. $n=1$ bo'lib, N sonining oxirgi bitta raqamidan tuzilgan son 5 ga bo'linsin. U holda, berilgan m xonali N natural sonni $N = (a_1 \cdot 10^{m-1} + a_2 \cdot 10^{m-2} + \dots + a_{m-1} \cdot 10) + 5k$ ko'rinishda yozish mumkin. O'ng tomondagi ikkita qo'shiluvchining har biri 5 ga bo'lingani uchun, ularning yig'indisi bo'lgan N soni ham 5 ga bo'linadi.

$n=2$ bo'lib, N sonining oxirgi ikkita raqamidan tuzilgan son 25 ga bo'linsin: $a_{m-1} \cdot 10 + a_m = 25 \cdot t$.

U holda, berilgan m xonali N natural sonni

$$N = (a_1 \cdot 10^{m-1} + a_2 \cdot 10^{m-2} + \dots + a_{m-2} \cdot 100) + 25 \cdot t$$

ko'rinishda yozish mumkin. O'ng tomondagi ikkita qo'shiluvchilarning har biri 25 ga bo'lingani uchun, ularning yig'indisi bo'lgan N soni ham 25 ga bo'linadi.

Yuqorida yuritilgan mulohazalardan foydalanib (to'liqmas induksiya qo'llanilmoqda!), «Agar berilgan m xonali natural $N = a_1 \cdot 10^{m-1} + a_2 \cdot 10^{m-2} + \dots + a_{m-1} \cdot 10 + a_m$ sonning oxirgi n ta (bu yerda $n \leq m$) raqamidan tuzilgan son 5^n ga bo'linsa, N soni ham 5^n ga bo'linadi» degan farazni aytish mumkin.

6- misol. 2 dan katta bo'lgan dastlabki bir nechta juft sonlarni ikkita tub sonning yig'indisi ko'rinishida tasvirlash mumkin: $4 = 2 + 2$, $6 = 3 + 3$, $8 = 3 + 5$, $10 = 3 + 7 = 5 + 5$, ..., $50 = 13 + 37$.

To'liqsiz induksiya yordamida «2 dan katta bo'lgan har qanday juft sonni ikkita tub sonning yig'indisi ko'rinishida yozish mumkin» degan xulosaga kelamiz. Bu xulosaning to'g'ri yoki noto'g'ri ekanligi hozirgacha isbotlanmagan. Bu muammo L. Eyl er – X. Goldbax muammosi deb yuritiladi.



M a s h q l a r

2.131. Quyidagi tengliklarning tuzilishidagi qonuniyatni aniqlang va uni umumlashtiring: $1^3 = 1^2$; $1^3 + 2^3 = (1 + 2)^2$; $1^3 + 2^3 + 3^3 = (1 + 2 + 3)^2$;

2.132. $a_4 + a_5 + \dots + a_n$ yig'indini yunon harfi Σ («sigma») dan

foydalanib, $\sum_{i=4}^n a_i$ ko'rinishda belgilash mumkin: $\sum_{i=4}^n a_i =$

$$= a_4 + a_5 + \dots + a_n.$$

Quyidagi yig'indilarni yoyib yozing:

a) $\sum_{i=1}^n \frac{2}{i^2}$;

b) $\sum_{i=1}^n i^3$;

d) $\sum_{i=1}^n \frac{i}{i+1}$;

e) $\sum_{i=1}^n \frac{(-1)^i}{i^2}$.

2.133. Σ belgisi yordami bilan yozing:

a) $\frac{1}{1 \cdot 2} + \frac{1}{2 \cdot 3} + \dots + \frac{1}{n(n+1)}$;

b) $1 \cdot 4 + 2 \cdot 7 + 3 \cdot 10 + \dots + n(3n + 1)$.

2.134. $a_4 \cdot a_5 \cdot a_6 \cdot \dots \cdot a_n$ ko'paytmani yunon harfi Π («pi») dan

foydalanib, $\prod_{i=4}^n a_i$ ko'rinishda belgilash mumkin:

$$\prod_{i=4}^n a_i = a_4 \cdot a_5 \cdot a_6 \cdot \dots \cdot a_n.$$

Ko'paytmalarni yoyib yozing:

a) $\prod_{i=1}^4 \frac{i}{3-i+i^2}$;

b) $\prod_{i=1}^5 \frac{i+1}{(i-1)i}$;

d) $\prod_{i=1}^n \left(2 - \frac{3}{i^3}\right)$;

e) $\prod_{i=1}^n i^3$.

2.135. Ko'paytmalarni Π belgisi yordami bilan yozing:

a) $\left(1 - \frac{1}{4}\right)\left(1 - \frac{1}{9}\right) \cdot \dots \cdot \left(1 - \frac{1}{(n+1)^2}\right)$;

b) $\frac{1}{2} \cdot \frac{5}{6} \cdot \frac{9}{10} \cdot \frac{13}{14}$.

2.136. To'liqmas induksiya yordamida « m xonali natural son K ning oxirgi n ta raqamlaridan tuzilgan son 2^n ga (3^n ga) bo'lsa, K sonining o'zi ham 2^n ga (3^n ga) bo'linadi», degan farazni aytish mumkinmi?

2.137. Qadimgi Samarqand madrasalari o'quv qo'llanmalarida sonlar ustida bajarilgan amallar natijalarini tekshirishda *mezon* usulidan foydalanganlar. *Mezon* arabcha so'z bo'lib, o'zbek tilida «o'lcham», «o'lchov» kabi ma'nolarni beradi. Eslatilgan o'quv qo'llanmalarda sonning mezoni sifatida, shu sonni 9 soniga bo'lishda hosil bo'ladigan qoldiq olingan. Masalan, 8 sonining mezoni 8 soniga,

21 sonining mezoni 3 soniga teng deb olingan. Induksiya va 9 ga bo'linish belgisidan foydalanib, quyidagi tasdiqlarni isbot qiling:

a) ko'p xonali sonning mezoni shu son tarkibidagi raqamlar yig'indisining mezoniga teng. Masalan, 467 ning mezoni $4 + 6 + 7 = 17$, $1 + 7 = 8$;

b) ikki son ko'paytmasi (ayirmasi, bo'linmasi)ning mezoni shu sonlar mezonlarining ko'paytmasiga (ayirmasiga, bo'linmasiga) teng.

2. Matematik induksiya metodi. Yuqorida biz to'liqsiz induksiya va to'liq induksiya bilan tanishdik. Ularning birinchisini tatbiq etish noto'g'ri xulosaga olib kelishi mumkin, ikkinchisini tatbiq etish esa ko'p hollarda katta qiyinchilik tug'diradi. Shu bois, ularning tatbiq doirasi tordir. Endi tatbiq doirasi birmuncha kengroq bo'lgan va *matematik induksiya metodi* deb ataluvchi isbotlash usulini qaraymiz. Bu metodning mohiyatini bayon etishdan oldin, bir necha misollar qaraymiz.

1- misol. Agar $4^n > n^2$ ($n \in \mathbb{N}$) tengsizlik n ning $n = k$ ($k \in \mathbb{N}$) qiymatida to'g'ri bo'lsa, u holda bu tengsizlik n ning $n = k + 1$ qiymatida ham to'g'ri bo'lishini isbotlang.

I s b o t. Berilgan tengsizlik n ning $n = k$ qiymatida to'g'ri bo'lgani uchun, $4^k > k^2$ (1) to'g'ri tengsizlikka egamiz. $n = k + 1$ bo'lsa, berilgan tengsizlik $4^{k+1} > (k + 1)^2$ (2) ko'rinishini oladi.

Biz (1) tengsizlikning to'g'ri ekanligidan foydalanib, (2) tengsizlikning to'g'ri ekanligini ko'rsatamiz.

$4^k > k^2$ bo'lgani uchun

$$4^{k+1} = 4 \cdot 4^k > 4k^2 = k^2 + 2k^2 + k^2 \quad (3)$$

tengsizlikni hosil qilamiz. $k^2 \geq k$, $k^2 \geq 1$ bo'lgani uchun, (3) dan $4^{k+1} > k^2 + 2k + 1 = (k + 1)^2$ tengsizlik hosil bo'ladi.

Demak, (1) tengsizlikning to'g'ri ekanligidan (2) tengsizlikning ham to'g'ri ekanligi kelib chiqadi, ya'ni $4^n > n^2$ tengsizlik n ning $n = k$ ($k \in \mathbb{N}$) qiymatida to'g'ri bo'lsa, u holda bu tengsizlik n ning $n = k + 1$ qiymatida ham to'g'ri bo'ladi.

2- misol. Agar $1 + 3 + 5 + \dots + (2n - 1) = n^2$ tenglik n ning $n = k$ ($k \in \mathbb{N}$) qiymatida to'g'ri bo'lsa, u holda bu tenglik n ning $n = k + 1$ qiymatida ham to'g'ri bo'lishini isbotlang.

Isbot. Berilgan tenglik $n = k$ bo'lganda

$$1 + 3 + 5 + \dots + (2k - 1) = k^2 \quad (4)$$

ko'rinishni, $n = k + 1$ bo'lganda esa

$$1 + 3 + 5 + \dots + (2k + 1) = (k + 1)^2 \quad (5)$$

ko'rinishni oladi.

Biz (4) tenglikning to'g'ri ekanligidan, (5) tenglikning ham to'g'ri ekanligi kelib chiqishini ko'rsatamiz.

(4) tenglik to'g'ri bo'lsin. U holda, $1 + 3 + 5 + \dots + (2k + 1) = (1 + 3 + 5 + \dots + (2k - 1)) + (2k + 1) = k^2 + (2k + 1) = (k + 1)^2$ tenglik, ya'ni (5) tenglik ham to'g'ri bo'ladi.

Demak, $1 + 3 + 5 + \dots + (2n - 1) = n^2$ tenglik n ning $n = k$ ($k \in \mathbb{N}$) qiymatida to'g'ri bo'lsa, u holda bu tenglik n ning $n = k + 1$ qiymatida ham to'g'ri bo'ladi.

Endi quyidagi tasdiqlarni qaraymiz:

1) $4^n > n^2$, ($n \in \mathbb{N}$);

2) $1 + 3 + 5 + \dots + (2n - 1)^2 = n^2$, ($n \in \mathbb{N}$).

Bu tasdiqlarning har biri natural son n ga bog'liq bo'lgan tasdiqdur. $n = 1$ bo'lganda ularning ikkalasi ham to'g'ri ekanligini ko'rish qiyin emas.

$4^n > n^2$ tengsizlik $n = k$ ($k \in \mathbb{N}$) da to'g'ri deb faraz qilaylik. U holda bu farazdan, $4^n > n^2$ tengsizlikning $n = k + 1$ bo'lganda ham to'g'ri bo'lishi kelib chiqadi (1- misol). Xuddi shunga o'xshash, $1 + 3 + 5 + \dots + (2n - 1) = n^2$ tenglik $n = k$ da to'g'ri degan farazdan, bu tenglikning $n = k + 1$ uchun ham to'g'ri ekanligi kelib chiqadi (2- misol).

Qaralayotgan tasdiqlarning har biri $n = 1$ da to'g'ri va tasdiq $n = k$ uchun to'g'ri degan farazdan, uning $n = k + 1$ uchun ham to'g'ri ekanligi kelib chiqadi. Shu sababli tasdiq n ning barcha natural qiymatlarida o'rinli bo'ladi. Bunday xulosa chiqarishda matematik induksiya aksiomasi (yoki matematik induksiya prinsipi) asos qilib olinadi.

Matematik induksiya aksiomasi: agar natural son n ga bog'liq bo'lgan $A(n)$ tasdiq $n = k_0$ ($k_0 \in \mathbb{N}$) uchun to'g'ri bo'lsa va $A(n)$ tasdiq $n = k$ da (bu yerda $k > k_0$) to'g'ri ekanligidan uning $n = k + 1$

da ham to'g'ri ekanligi kelib chiqsa, u holda $A(n)$ tasdiq barcha $n \geq k_0$ natural sonlar uchun to'g'ri bo'ladi.

Matematik induksiya aksiomasi, natural son n ga bog'liq bo'lgan $A(n)$ tasdiqning barcha natural n larda to'g'ri ekanligini isbotlashning quyidagi usulini beradi:

1) $A(n)$ tasdiqning $n = 1$ da to'g'riligini ko'rsatamiz (induksiya bazisi);

2) $A(n)$ tasdiq $n = k$ da to'g'ri deb faraz qilamiz (induksiya farazi);

3) qilingan farazdan foydalanib, $A(n)$ tasdiq $n = k + 1$ da ham to'g'ri bo'lishligini ko'rsatamiz (induksiya qadami).

$A(n)$ tasdiqning barcha natural n sonlari uchun to'g'ri ekanligini isbotlashning bu usuli *matematik induksiya metodi* deb ataladi. Bu metodning qo'llanishiga doir misol qaraymiz.

3- misol. n ning barcha natural qiymatlarida $n^3 + 11n$ ifodaning qiymati 6 ga bo'linishini isbotlang.

Isbot. Matematik induksiya metodini qo'llaymiz.

1) $n = 1$ bo'lsin. U holda $n^3 + 11n = 1^3 + 11 \cdot 1 = 12$ ga ega bo'lamiz. 12 soni 6 ga bo'linadi.

2) $n = k$ bo'lsa, $n^3 + 11n$ ifodaning qiymati $k^3 + 11k$ soniga teng bo'ladi. Bu son 6 ga bo'linadi deb faraz qilamiz.

3) $n = k + 1$ bo'lsin. U holda, $n^3 + 11n = (k + 1)^3 + 3(k + 1) = (k^3 + 11k) + 3k(k + 1) + 12$ tenglik o'rinli bo'ladi.

Farazimizga ko'ra, $k^3 + 11k$ soni 6 ga bo'linadi. Ketma-ket keluvchi ikkita natural sonning ko'paytmasi bo'lgan $k(k + 1)$ soni 2 ga bo'lingani uchun, $3k(k + 1)$ soni 6 ga bo'linadi. Shuning uchun $(k^3 + 11k) + 3k(k + 1) + 12$ soni 6 ga bo'linadi.

Demak, n ning barcha natural qiymatlarida $n^3 + 11n$ ifoda 6 ga bo'linadi.

Matematik induksiya metodi biror-bir tasdiqni *hosil qilish* usuli emas, balki *berilgan (tayyor) tasdiqni* isbotlash usuli ekanligini eslatib o'tamiz.

Ba'zan bu metod noto'g'ri ham qo'llanilishi mumkin. Bir misol.

4- m i s o l. Har qanday n natural soni o'zidan keyin keluvchi $n + 1$ natural soniga «tengdir».

«I s b o t». Har qanday k natural soni uchun tasdiq to'g'ri, ya'ni $k = k + 1$ bo'ladi, deb faraz qilaylik. Agar endi bu tenglikning har ikki qismiga 1 soni qo'shilsa, $k + 1 = k + 2$ bo'ladi. Demak, tasdiq barcha n larda «o'rinli». Bunda isbotning bazis qismi «unutib» qo'yilgan. Boshidayoq $1 = 2$ bo'lib qolayotgani ma'lum edi.



M a s h q l a r

2.138. n ning barcha natural qiymatlarida tengsizlik o'rinli bo'lishini isbotlang:

a) $2^n \geq n + 1$;

b) $\frac{1}{n} \leq 1 + \frac{1}{2} + \frac{1}{3} + \dots + \frac{1}{2^n - 1} \leq n$;

d) $(1 + a)^n \geq 1 + na$ (bu yerda $a \geq -1$).

2.139. n ning barcha natural qiymatlarida tenglik o'rinli bo'lishini isbotlang:

a) $1 + 2 + 3 + \dots + n = \frac{n(n+1)}{2}$;

b) $1^2 + 2^2 + 3^2 + \dots + n^2 = \frac{n(n+1)(2n+1)}{6}$;

d) $1^3 + 2^3 + 3^3 + \dots + n^3 = \frac{n^2(n+1)^2}{4}$;

e) $1 \cdot 2 + 2 \cdot 3 + \dots + (n-1) \cdot n = \frac{(n-1) \cdot n \cdot (n+1)}{3}$.

n ning barcha natural qiymatlarida a_n soni b soniga bo'linishini isbotlang, bunda:

2.140. $a_n = 4^n + 15n - 1$, $b = 9$.

2.141. $a_n = n^3 + 5n$, $b = 6$.

2.142. $a_n = 7^n + 3n - 1$, $b = 9$.

- 2.143. $a_n = 6^{2n} + 19^n - 2^{n+1}$, $b = 17$.
- 2.144. $a_n = (2n - 1)^3 - (2n - 1)$, $b = 24$.
- 2.145. $a_n = n^3 + 11n$, $b = 6$.
- 2.146. $a_n = n^2(n^2 - 1)$, $b = 4$.
- 2.147. $a_n = n(2n + 1)(7n + 1)$, $b = 6$.
- 2.148. $a_n = 2^n + 2^{n+1}$, $b = 6$.
- 2.149. $a_n = n^2(n^2 - 1)$, $b = 12$.
- 2.150. $a_n = 18^n - 1$, $b = 17$.
- 2.151. $a_n = 3^{3n+2} + 7^n$, $b = 10$.
- 2.152. $a_n = 7 \cdot 5^{2n} + 12 \cdot 6^n$, $b = 19$.
- 2.153. $a_n = 5^{n+3} \cdot 2^n - 125$, $b = 45$.



III b o b

KOMPLEKS SONLAR VA ULAR USTIDA AMALLAR

1- §. Algebraik shakldagi kompleks sonlar va ular ustida amallar

Kompleks sonlar ta'limoti ilm-u fanda, xususan, matematikada alohida o'rin tutadi. Tez rivojlanayotgan bu soha texnikada, shuningdek ishlab chiqarishning ko'plab sohalarida g'oyat keng qo'llanishga ega. Shu sonlar haqida ayrim ma'lumotlarni keltiramiz.

Xususiyl bir misoldan boshlaylik.

$x^2 + 4 = 0$ tenglamani yechish jarayonida $x_1 = 2\sqrt{-1}$ va $x_2 = -2\sqrt{-1}$ «sonlar» hosil bo'ladi. Haqiqiy sonlar orasida esa bunday «sonlar» mavjud emas. Bunday holatdan qutulish uchun $\sqrt{-1}$ ga son deb qarash zarurati paydo bo'ladi.

Bu yangi son hech qanday real kattalikning o'lchamini yoki uning o'zgarishini ifodalamaydi. Shu sababli uni *mavhum* (xayoliy, haqiqatda mavjud bo'lmagan) *birlik* deb atash va maxsus belgilash qabul qilingan: $\sqrt{-1} = i$. Mavhum birlik uchun $i^2 = -1$ tenglik o'rinlidir.

$a + bi$ ko'rinishdagi ifodani qaraymiz. Bu yerda a va b lar istalgan haqiqiy sonlar, i esa mavhum birlik. $a + bi$ ifoda *haqiqiy* son a va mavhum son bi lar «kompleksi»dan iborat bo'lgani uchun uni kompleks son deb atash qabul qilingan.

$a + bi$ ifoda *algebraik shakldagi kompleks* son deb ataladi, bu yerda $a \in R$, $b \in R$, $i^2 = -1$. Bu paragrafda $a + bi$ ni qisqalik uchun «algebraik shakldagi kompleks son» deyish o'rniga «kompleks son» deb ishlataveramiz.

Kompleks sonlarni bitta harf bilan belgilash qulay. Masalan, $a + bi$ ni $z = a + bi$ ko'rinishda belgilash mumkin. $z = a + bi$ kompleks sonning *haqiqiy* qismi a ni $\text{Re}(z)$ (fransuzcha reele – haqiqiy)

bilan, *mavhum* qismi b ni esa $\text{Im}(z)$ (fransuzcha *imaginaire* – *mavhum*) bilan belgilash qabul qilingan: $a = \text{Re}(z)$, $b = \text{Im}(z)$.

Agar $z = a + bi$ kompleks son uchun $b = 0$ bo'lsa, haqiqiy son $z = a$ hosil bo'ladi. Demak, haqiqiy sonlar to'plami R barcha kompleks sonlar to'plami C ning qism to'plami bo'ladi: $R \subset C$.

1- m i s o l. $z_1 = 1 + 2i$, $z_2 = 2 - i$, $z_3 = 2, 1$, $z_4 = 2i$, $z_5 = 0$ kompleks sonlarning haqiqiy va mavhum qismlarini topamiz.

Y e c h i s h. Kompleks son haqiqiy va mavhum qismlarining aniqlanishiga ko'ra, quyidagilarga egamiz:

$$\text{Re}(z_1) = 1; \text{Re}(z_2) = 2; \text{Re}(z_3) = 2, 1; \text{Re}(z_4) = 0; \text{Re}(z_5) = 0;$$

$$\text{Im}(z_1) = 2; \text{Im}(z_2) = -i; \text{Im}(z_3) = 0; \text{Im}(z_4) = 2i; \text{Im}(z_5) = 0.$$

Kompleks sonlar uchun « \ll », « \gg » munosabatlari aniqlanmaydi, lekin teng kompleks sonlar tushunchasi kiritiladi.

Haqiqiy va mavhum qismlari mos ravishda teng bo'lgan kompleks sonlar *teng kompleks sonlar* deb ataladi.

Masalan, $z_1 = 1,5 + \frac{4}{5}i$ va $z_2 = \frac{3}{2} + 0,8i$ sonlari uchun $\text{Re}(z_1) = \text{Re}(z_2) = 1,5$, $\text{Im}(z_1) = \text{Im}(z_2) = 0,8$. Demak, $z_1 = z_2$.

Bir-biridan faqat mavhum qismlarining ishorasi bilan farq qiladigan ikki kompleks son *o'zaro qo'shma kompleks sonlar* deyiladi. $z = a + bi$ kompleks songa qo'shma kompleks son $\bar{z} = a - bi$ ko'rinishda yoziladi. Masalan, $6 + 7i$ va $6 - 7i$ lar qo'shma kompleks sonlardir: $\overline{6 + 7i} = 6 - 7i$. Shu kabi \bar{z} soniga qo'shma son $\overline{\bar{z}} = z$ bo'ladi. Masalan, $\overline{\overline{6 + 7i}} = \overline{6 - 7i} = 6 + 7i$. a haqiqiy songa qo'shma son a ning o'ziga teng: $\bar{a} = \overline{a + 0 \cdot i} = a - 0 \cdot i = a$. Lekin bi mavhum songa qo'shma son $\overline{bi} = -bi$ dir. Chunki $\overline{\overline{bi}} = \overline{0 + bi} = 0 - bi = -bi$, $a, b \in R$.

Kompleks sonlar ustida arifmetik amallar quyidagicha aniqlanadi:

$$(a + bi) + (c + di) = (a + c) + (b + d)i; \quad (1)$$

$$(a + bi) - (c + di) = (a - c) + (b - d)i; \quad (2)$$

$$(a + bi) \cdot (c + di) = (ac - bd) + (ad + bc)i; \quad (3)$$

$$\frac{a+bi}{c+di} = \frac{ac+bd}{c^2+d^2} + \frac{b-a d}{c^2+d^2} i. \quad (4)$$

(1) va (2) tengliklarni bevosita qo'llash qiyin emas. Kompleks sonlarni ko'paytirish amalini $i^2 = -1$ ekanligini e'tiborga olib, ko'phadlarni ko'paytirish kabi bajarish mumkin.

$$\begin{aligned} \text{2- misol. } (2-i) \cdot \left(\frac{3}{4} + 2i\right) &= 2 \cdot \frac{3}{4} + 2 \cdot 2i - i \cdot \frac{3}{4} - 2i^2 = \\ &= \frac{3}{2} + 4i - \frac{3}{4}i + 2 = \frac{7}{4} + \frac{13}{4}i. \end{aligned}$$

(4) formulani eslab qolish va amaliyotda bevosita qo'llash ancha qiyin. Shu sababli $\frac{a+bi}{c+di}$ ni hisoblash uchun, uning surati va maxrajini $c-di$ ga ko'paytirib, tegishli amallarni bajarish qulaydir.

$$\begin{aligned} \text{3- misol. } \frac{2-i}{-3+2i} &= \frac{(2-i)(-3-2i)}{(-3+2i)(-3-2i)} = \frac{-6-4i+3i-2}{9+6i-6i+4} = \\ &= \frac{-8-i}{13} = \frac{-8}{13} - \frac{1}{13}i. \end{aligned}$$

Kompleks sonlarni qo'shish va ko'paytirish amallari xossalari haqiqiy sonlarnikiga o'xshash:

- | | |
|---------------------------------|----------------------|
| 1) $z + w = w + z;$ | 1') $zw = wz;$ |
| 2) $(z + w) + t = z + (w + t);$ | 2') $(zw)t = z(wt);$ |
| 3) $z + 0 = z;$ | 3') $z \cdot 1 = z;$ |
| 4) $z(w + t) = zw + zt.$ | |

$z + w = 0$ tenglikni qanoatlantiruvchi z , w kompleks sonlari o'zaro qarama-qarshi sonlar deyiladi. z kompleks soniga qarama-qarshi sonni $-z$ bilan belgilash qabul qilingan.

$z = a + bi$ kompleks songa qarama-qarshi bo'lgan yagona kompleks son mavjud va bu son $-z = -a - bi$ kompleks sonidan iborat.

$zw = 1$ tenglikni qanoatlantiradigan z va w kompleks sonlari o'zaro teskari kompleks sonlar deyiladi. $z = 0$ soniga teskari son

mavjud emas. Har qanday $z \neq 0$ kompleks songa teskari kompleks son mavjud. Bu son $\frac{1}{z}$ sonidan iborat.

$z = a + bi$ kompleks songa teskari bo'lgan $\frac{1}{z}$ sonini topamiz:

$$\frac{1}{z} = \frac{1}{a+bi} = \frac{a-bi}{(a+bi)(a-bi)} = \frac{a}{a^2+a^2} - \frac{b}{a^2+b^2}i.$$

1- teorema. $\overline{z+w} = \bar{z} + \bar{w}$.

Isbot. $z = a + bi$, $w = c + di$ bo'lsin. U holda $\bar{z} = a - bi$, $\bar{w} = c - di$ va

$$\begin{aligned} \overline{z+w} &= \overline{(a+bi) + (c+di)} = \overline{(a+c) + (b+d)i} = \\ &= a+c - (b+d)i = (a-bi) + (c-di) = \bar{z} + \bar{w}. \end{aligned}$$

2- teorema. $\overline{zw} = \bar{z} \cdot \bar{w}$.

Isbot. Haqiqatan,

$$\begin{aligned} \overline{zw} &= \overline{(a+bi)(c+di)} = \overline{(ac-bd) + (ad+bc)i} = ac-bd - \\ &- (ad+bc)i. \text{ Ikkinchi tomondan, } \bar{z} \cdot \bar{w} = (a-bi)(c-di) = ac - \\ &- bd - (ad+bc)i. \text{ Natijalar bir xil. Demak, } \overline{zw} = \bar{z} \cdot \bar{w}. \end{aligned}$$

Xususan, $z \neq 0$ bo'lsa, z ga teskari bo'lgan $\frac{1}{z}$ songa qo'shma son z ga qo'shma sonning teskarisi bo'ladi. Haqiqatan,

2- teoremaga ko'ra $z \cdot \frac{1}{z} = 1$ tenglikdan $\bar{z} \cdot \overline{\left(\frac{1}{z}\right)} = \bar{1} = 1$ olinadi.

$$\text{Bundan } \overline{\left(\frac{1}{z}\right)} = \frac{1}{\bar{z}}.$$

Natija. *Kompleks sonning natural ko'rsatkichli darajasiga qo'shma son berilgan songa qo'shma sonning shu natural ko'rsatkichli darajasiga teng: $\bar{z}^n = (\bar{z})^n$.*



Mashqlar

1.1. Kompleks son z ning haqiqiy qismi $\text{Re}(z)$ ni va mavhum qismi $\text{Im}(z)$ ni toping:

- | | | |
|---------------------------------------|----------------------|------------|
| a) $z = -5 + 8i$; | f) $z = 0,5 + 3i$; | j) $8i$; |
| b) $z = 6 + \frac{1}{2}i$; | g) $z = 2 + 0,3i$; | k) 4 ; |
| d) $z = -15 + 2i$; | h) $z = -4,1 + 2i$; | l) 0 ; |
| e) $z = \frac{1}{2} + \frac{3}{2}i$; | i) $z = -3 - 4i$; | m) $-3i$. |

1.2. Agar:

- | | |
|---------------------------|------------------------|
| a) $\text{Re}(z) = -4$, | $\text{Im}(z) = 8$; |
| b) $\text{Re}(z) = 0$, | $\text{Im}(z) = 1,2$; |
| d) $\text{Re}(z) = 1,2$, | $\text{Im}(z) = 0$; |
| e) $\text{Re}(z) = 0$, | $\text{Im}(z) = 0$ |

bo'lsa, z kompleks sonini algebraik shaklda yozing.

1.3. Teng kompleks sonlarni toping:

$$\frac{1}{2} + \frac{1}{3}i; 0,5 + 3i; \frac{1}{4} + \frac{2}{6}i; \sqrt{9} - 4i; \sqrt{9} - \sqrt{81}i; 3 - 4i.$$

1.4. a) Kompleks sonlardan qaysilari teng:

$$3i; -4 + 5i; \frac{1}{3} + i; -\frac{1}{4} - 8i; 0, (3) + i; -\frac{2}{8} - \sqrt{64}i; \sqrt[3]{81}i?$$

b) $(4x - 3y) + (3x + 5y)i = 10 - (3x - 2y - 30)i$ bo'lsa, x va y larni toping ($x, y \in R$).

1.5. Agar:

- | | | |
|--------------------|-------------------|-------------------------------|
| a) $z = -3 + 5i$; | f) $z = -3i$; | j) $z = \frac{1}{3} + 3,4i$; |
| b) $z = 3 - 5i$; | g) $z = 4,2$; | k) $z = 0$; |
| d) $z = -3 - 5i$; | h) $z = 4i$; | l) $z = \sqrt{81} + 4i$; |
| e) $z = 3 + 5i$; | i) $z = 4, (3)$; | m) $z = -0, (3) - 2, (3)i$ |

bo'lsa, \bar{z} ni toping.

1.6. Yig'indini toping:

- | | |
|-----------------------------|--------------------------------|
| a) $(-3 + 2i) + (4 - i)$; | e) $4 + (-3 + i)$; |
| b) $(4 + 5i) + (4 - 5i)$; | f) $(1,4 - 3i) + (2,6 - 4i)$; |
| d) $(5 + 2i) + (-5 - 2i)$; | g) $(3 + 8i) + (3 - 8i)$; |

h) $(-7 + 3i) + (7 - 3i)$;

k) $-15i + (-4 + 5i)$;

i) $4,3 + (1,7 - 9i)$;

l) $(14 + 2i) + 8i$;

j) $8i + (4 - 6i)$;

m) $81 + (43 - 17i)$.

3.7. Yig'indini toping:

a) $\left(\frac{1-\sqrt{2}}{2} + \frac{1+\sqrt{2}}{3}i\right) + \left(\frac{1+\sqrt{2}}{2} + \frac{1-\sqrt{2}}{3}i\right)$;

b) $(\cos^2 \alpha + i \sin^2 \alpha) + (\sin^2 \alpha + i \cos^2 \alpha), (\alpha \in R)$;

d) $(0, (3) + i \cdot 1, (5)) + (0, (6) + i \cdot 1, (55))$;

e) $(\operatorname{Re}(1 + 2i) + 15i) + (3 - i \cdot \operatorname{Im}(1 + 2i))$.

3.8. Ayirmani toping:

a) $(-5 + 2i) - (8 - 9i)$;

f) $(32 + 4, (5)i) - (32 + i)$;

b) $(5 + 21i) - (9i + 8)$;

g) $\left(\frac{1-\sqrt{2}}{2} + \frac{1-\sqrt{2}}{2}i\right) - (1 + i)$;

d) $(4 - (42 - 3i))$;

h) $4,8 - \left(\frac{1-\sqrt{2}}{3} - i\right)$;

e) $(14 + 3i) - (21 + 3i)$;

i) $i - (3i + 8)$.

3.9. Ko'paytmani hisoblang:

a) $(3 + 5i)(2 + 3i)$;

h) $(2 + 3i)(2 - 3i)$;

b) $(4 + 7i)(2 - i)$;

i) $4 \cdot (8,3 - i)$;

d) $(5 - 3i)(2 - 5i)$;

j) $(5 - 2i)(2i + 5)$;

e) $(-2 + i)(7 - 3i)$;

k) $(-3 + i)(3 - i)$;

f) $\left(\frac{1}{2} + i\right)\left(\frac{1}{4} - i\right)$;

l) $0 \cdot (4,5 - i)$;

g) $\left(\frac{4}{7} + 3i\right)\left(\frac{7}{4} + 4,7i\right)$;

m) $\left(\frac{1}{3} - 0,3\right) \cdot i$.

3.10. Ikki kompleks sonning bo'linmasini toping:

a) $\frac{1+i}{1-i}$;

b) $\frac{3-4i}{2+i}$;

d) $\frac{2+3i}{2-3i}$;

$$e) \frac{1+2i}{3-2i}; \quad f) \frac{5-4i}{-3+2i}; \quad g) \frac{-7+2i}{5-4i};$$

$$h) \frac{3-4i}{-3+2i}; \quad i) \frac{14-3i}{3i+2}; \quad j) \frac{51}{4-i};$$

$$k) \frac{4-i}{51}; \quad l) \frac{31i}{17+i}; \quad m) \frac{14+i}{31i};$$

$$n) \frac{0}{3i}; \quad o) \frac{1+4i}{1-5i}; \quad p) \frac{1}{1+5i};$$

3.11. Qu'shma kompleks sonlarning ko'paytmasi shaklida yozing ($a, b \in R$):

$$a) a^2 + 4b^2;$$

$$h) 11a^2 + 48b^6;$$

$$b) 9a^2 + 25b^2;$$

$$i) 13a^4 + 29b^8;$$

$$d) 8a^2 + 16b^2;$$

$$j) a^{2n} + 33b^{2n} (n \in N);$$

$$e) 81a^2 + 5b^2;$$

$$k) a^{2k} + b^{2n} (k, n \in N);$$

$$f) 3a^2 + 45b^4;$$

$$l) \sqrt{3}a^2 + b^{18};$$

$$g) 10a^2 + 56b^4;$$

$$m) 9a^2 + \sqrt{5}b^{20};$$

N a m u n a: $\sqrt{7}a^8 + 81b^4 = (\sqrt[4]{7}a^4)^2 - (9b^2i)^2 = (\sqrt[4]{7}a^4 - 9b^2i)(\sqrt[4]{7}a^4 + 9b^2i).$

3.12. Mavhum birlik i ning quyidagi darajalarini hisoblang va xulosa chiqaring:

$$a) i^1; \quad d) i^3; \quad f) i^5; \quad h) i^7; \quad j) i^9; \quad l) i^{11};$$

$$b) i^2; \quad e) i^4; \quad g) i^6; \quad i) i^8; \quad k) i^{10}; \quad m) i^{12};$$

3.13. Amallarni bajaring:

$$a) -3i + 5 + 8i(3 - i);$$

$$h) 4(0,5 - 2,5i)(3 + i) + 5i;$$

$$b) (4 + 2i)(-1 - 3i) + 5 - 8i;$$

$$i) 4,2(3 - i)(1 + i) + 2 + 3i;$$

$$d) 3i(1 + i) + 3i(3 - i);$$

$$j) 3 + 5i + 5i^{1999};$$

$$e) \frac{1}{2}i(5 - 2i) + \frac{1}{3}i(9 - 8i);$$

$$k) 35 - i^{2000} + i^{1997};$$

$$f) (5 - 3i)(4 + i) + 15i;$$

$$l) i^{2001}(3 + 5i^4);$$

$$g) 16 - (15 - i)(1 + i);$$

$$m) i^{2002} - i^{2001} - i^{1999};$$

3.14. Hisoblang:

a) $\frac{(2-3i)(3-2i)}{1+i};$

h) $\frac{13}{1-4i} + \frac{11}{1+4i};$

b) $\frac{(3-i)(1+3i)}{2-i};$

i) $\frac{1-i}{1+i} + \frac{3-i}{3+i};$

d) $\frac{3-4i}{(1+i)(2-i)};$

j) $\frac{i^{18}+i^{19}}{2-3i} + \frac{1}{3+4i};$

e) $\frac{2-3i}{(1-i)(3+i)};$

k) $\frac{2-3i}{2+3i} \cdot i^{18} + \frac{i}{1+i};$

f) $\frac{11}{1-2i} - \frac{13}{2-i};$

l) $\frac{4i^8}{9} + i(1+i^9);$

g) $\frac{3-5}{3+i} + \frac{2+3i}{2-i};$

m) $i^3(1-i^4) + i^{21}.$

3.15. Amallarni bajaring:

a) $(3-2i)^2;$

f) $(3+2i)^2 - (3-2i);$

b) $(4+3i)^2;$

g) $(-3+5i) + (-3-5i);$

d) $\left(\frac{1-2i}{1+i}\right)^2;$

h) $\left(\frac{i+1}{i-1}\right)^2;$

e) $\left(\frac{1+i}{1-i}\right)^2;$

i) $\left(\frac{4+i}{3-i}\right)^2.$

3.16. Qo'shma kompleks sonlar yig'indisi va ko'paytmasi haqiqiy sonlardan iborat ekanligini isbot qiling.

3.17. $z = a + bi$, $w = c + di$ kompleks sonlar berilgan: a) agar

$z + w = A \in R$ va $zw = B \in R$ bo'lsa, $w = \bar{z}$ bo'ladi; b) agar

$\frac{1}{z} + \frac{1}{w} = C \in R$ va $\frac{1}{z} \cdot \frac{1}{w} = D \in R$ bo'lsa, $w = \bar{z}$ bo'ladi.

Shuni isbot qiling.

3.18. a) x va y ning qanday haqiqiy qiymatlarida $6 - ixy$ va $x + y + 5i$ kompleks sonlar o'zaro qo'shma bo'ladi?

b) oldingi masalaning shartida x va y larning haqiqiy son bo'lishi talab qilinmasa, masala nechta yechimga ega bo'ladi? Misol keltiring.

3.19. Ildizlaridan biri: a) $2i$; b) $1-i$; d) $2-i$; e) $1-i\sqrt{5}$ bo'lgan haqiqiy koeffitsiyentli kvadrat tenglama tuzing.

3.20. Kvadrati shu sonning qo'shmasiga teng bo'lgan kompleks sonni toping.

2- §. Trigonometrik shakldagi kompleks sonlar va ular ustida amallar

1. Kompleks sonning trigonometrik shakli. Kompleks sonlarga oid ko'pgina tushunchalar ayoniy bo'lishi uchun kompleks sonni biror geometrik shakl (figura, tasvir) sifatida qarash qulaydir.

Biz $z = x + yi$ kompleks sonning geometrik shakli sifatida, XOY koordinata tekisligidagi $A(x; y)$ nuqtani yoki boshi $O(0; 0)$ nuqtada, oxiri esa $A(x; y)$ nuqtada bo'lgan \vec{OA} vektorni qabul qilamiz (17- a, b rasmlar). Bunda koordinata tekisligining har bir nuqtasi faqat bitta kompleks sonni tasvirlaydi va aksincha, har qanday kompleks son faqat bitta nuqtada tasvirlanadi. Haqiqiy sonlarga absissalar o'qining nuqtalari, bi ($i \in R$) sof mavhum sonlarga esa ordinatalar o'qining nuqtalari mos keladi. Shunga ko'ra, koordinatalar tekisligi *kompleks tekislik*, absissalar o'qi *haqiqiy o'q*, ordinatalar o'qi esa *mavhum o'q* deb ham ataladi.

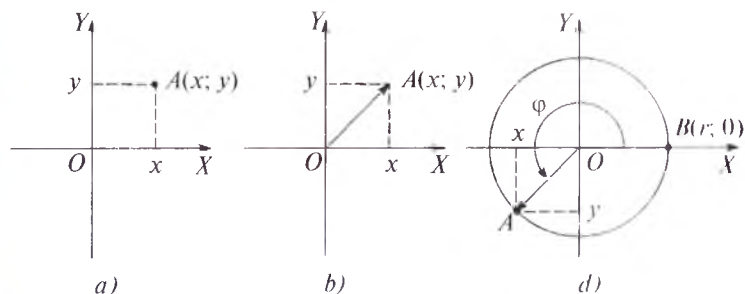

17- rasm.

$z = x + yi$ kompleks sonning geometrik tasviri bo'lgan vektor uning *radius-vektori* deyiladi. Har qanday $z = x + yi$ kompleks son yagona radius-vektorga ega, chunki x, y sonlari yagona $A(x; y)$ nuqtani (vektorning oxirini) aniqlaydi. Kompleks son radius-vektorining uzunligi shu *sonning moduli* deyiladi. $z = x + yi$ kompleks sonning modulini $|z|$ yoki r bilan belgilaymiz. $|z|, x, y$ haqiqiy sonlar quyidagi tenglik bilan bog'langan:

$$|z| = \sqrt{x^2 + y^2}. \quad (1)$$

Haqiqatan ham, ikki nuqta orasidagi masofa formulasiga ko'ra,

$$|z| = OA = \sqrt{(x-0)^2 + (y-0)^2} = \sqrt{x^2 + y^2} \quad \text{tenglik o'rinlidir (17- b rasm).}$$

1- m i s o l. $z = \sqrt{2} - i\sqrt{2}$ kompleks sonning modulini toping.

Y e c h i s h. $x = \sqrt{2}, y = -\sqrt{2}$ bo'lgani uchun,

$$|z| = \sqrt{(\sqrt{2})^2 + (-\sqrt{2})^2} = 2.$$

\vec{OA} vektor $z = x + iy \neq 0$ kompleks sonning radius-vektori bo'lsin (17- b rasm). Markazi $O(0; 0)$ nuqtada bo'lgan $r = |z|$ radiusli aylananing $B(r; 0)$ nuqtasini, O nuqta atrofida bu nuqta $A(x; y)$ nuqta bilan ustma-ust tushadigan qilib buramiz (17-d rasm). Bu ishni, bir-biridan 2π ga karrali bo'lgan burish burchagiga farq qiladigan cheksiz ko'p burish burchaklari yordamida amalga oshirish mumkin. Shu burish burchaklarining har biri $z = x + iy$ kompleks sonning *argumenti* deb ataladi.

17- d rasmda $z = x + iy$ kompleks sonning argumentlaridan biri bo'lgan φ burchak ko'rsatilgan.

$z = x + iy$ kompleks sonning barcha argumentlari to'plamini $\text{Arg}(z)$ bilan belgilaymiz.

Yuqoridagi mulohazalardan ko'rinadiki, agar $\varphi \in \text{Arg}(z)$ bo'lsa, u holda ixtiyoriy $k \in \mathbb{Z}$ son uchun $\varphi + 2\pi k \in \text{Arg}(z)$ bo'ladi. Shu sababli $\text{Arg}(z)$ to'plamni quyidagicha tasvirlash mumkin:

$$\text{Arg}(z) = \{\varphi + 2\pi k \mid k \in \mathbb{Z}\}.$$

Burish burchagining kosinusi va sinusi ta'riflaridan ko'rinishida, $z = x + yi$ kompleks sonning har qanday φ argumenti uchun quyidagi munosabatlar o'rinli:

$$\cos \varphi = \frac{x}{|z|}, \quad \sin \varphi = \frac{y}{|z|}.$$

Bu tengliklar asosida, $z = x + yi$ kompleks sonini $z = |z|(\cos \varphi + i \sin \varphi)$ ko'rinishida yozib olish mumkin. Bunday yozish *kompleks sonni trigonometrik shaklda tasvirlash* deb yuritiladi.

Kompleks son cheksiz ko'p argumentlarga ega bo'lgani uchun, uni cheksiz ko'p usullar bilan trigonometrik shaklda yozish mumkin. Shu sababli kompleks sonning trigonometrik shaklini tayin bir oraliqda yotadigan argument orqali yozish maqsadga muvofiqdir. Biz ana shunday oraliq sifatida $[0; 2\pi]$ oraliqni olamiz. Bu oraliqda har qanday $z (z \neq 0)$ kompleks sonining faqat bitta argumenti yotadi.

$z = x + yi$ kompleks sonining $[0; 2\pi]$ oraliqda yotadigan argumenti shu sonning *bosh argumenti* deyiladi va $\arg(z)$ bilan belgilanadi. Shunga muvofiq ravishda, $z = |z|(\cos(\arg(z)) + i \sin(\arg(z)))$ ni z kompleks sonning bosh trigonometrik shakli deb ataymiz. Bundan keyin, kompleks sonning argumenti va

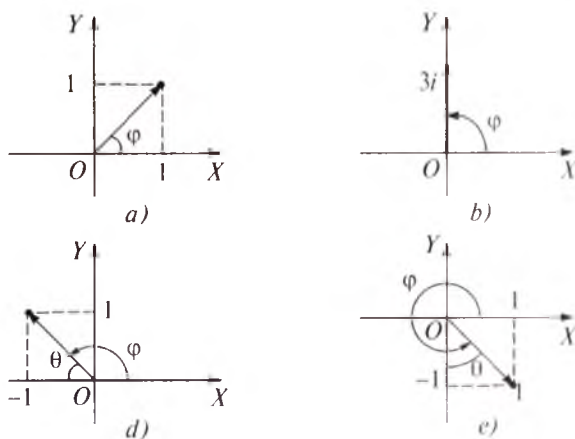

18- rasm.

kompleks sonning trigonometrik shakli deyilganda, mos ravishda kompleks sonning bosh argumenti va bosh trigonometrik shakli nazarda tutiladi.

Endi $z=0$ soni ustida to'xtalaymiz. Bu sonning moduli 0 ga teng, lekin argumenti aniqlanmaydi.

2- misol. a) $1+i$; b) $3i$; d) $-1+i$; e) $1-i$ sonlarini trigonometrik shaklda ifodalang.

Yechish.

$$\text{a) } |1+i| = \sqrt{1^2+1^2} = \sqrt{2}, \quad \varphi = \frac{\pi}{4},$$

$$1+i = \sqrt{2} \left(\cos \frac{\pi}{4} + i \sin \frac{\pi}{4} \right) \quad (18- a \text{ rasm});$$

$$\text{b) } |3i| = 3, \quad \varphi = \frac{\pi}{2}, \quad 3i = 3 \left(\cos \frac{\pi}{2} + i \sin \frac{\pi}{2} \right) \quad (18- b \text{ rasm});$$

$$\text{d) } |-1+i| = \sqrt{2}, \quad \theta = \frac{\pi}{4}, \quad \varphi = \pi - \theta = \frac{3\pi}{4},$$

$$-1+i = \sqrt{2} \left(\cos \frac{3\pi}{4} + i \sin \frac{3\pi}{4} \right) \quad (18- d \text{ rasm});$$

$$\text{e) } |1-i| = \sqrt{2}, \quad \varphi = \frac{3\pi}{2} + \theta \begin{cases} \sin \theta = \frac{1}{\sqrt{2}}; \\ \cos \theta = \frac{1}{\sqrt{2}}; \theta = \frac{\pi}{4}, \varphi = \frac{3\pi}{2} + \\ \theta \in \left(0; \frac{\pi}{2} \right) \end{cases}$$

$$+ \theta = \frac{7\pi}{4}, \quad 1-i = \sqrt{2} \left(\cos \frac{7\pi}{4} + i \sin \frac{7\pi}{4} \right) \quad (18- e \text{ rasm}).$$

3- misol. $M(z)$ va $N(w)$ nuqtalar orasidagi masofa $|z-w|$ ga tengligini isbotlang.

Isbot. $z = x_1 + iy_1$ va $w = x_2 + iy_2$ sonlari uchun $|z-w| = \sqrt{(x_1-x_2)^2 + (y_1-y_2)^2}$ ga egamiz. Bu tenglikning o'ng tomoni M va N nuqtalar orasidagi masofadir (19- rasm).

3- misoldan ko'rinadiki, $|z-z_0| = r (r > 0)$ tenglama markazi z_0 nuqtada bo'lgan r radiusli aylananing tenglamasidir.

4-misol. 1) $|z-1+i|=3$;

2) $|z-1+i|\leq 3$ shartni qanoatlantiruvchi barcha $z=x+iy$ nuqtalarning geometrik o'rnini aniqlang.

Yechish. 1) $|z-1+i|=|z-(1-i)|$ bo'lgani uchun $|z-(1-i)|=3$ tenglamaga ega bo'lamiz. Bu tenglama markazi $z_0=1-i$ nuqtada bo'lgan $r=3$ radiusli aylananing tenglamasidir;

2) $|z-1+i|\leq 3$ shartni qanoatlantiruvchi barcha $z=x+iy$ nuqtalarning geometrik o'rnini $|z-1+i|=3$ aylana bilan chegaralangan doiradan iborat.

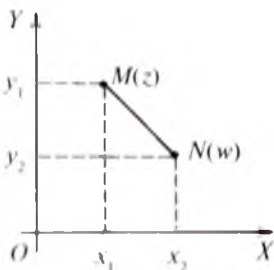

19-rasm.



Mashqlar

3.21. Kompleks tekislikning z kompleks songa mos keluvchi nuqtasini yasang, bunda:

- | | |
|--------------------|--|
| a) $z = 1 + 2i$; | j) $z = 0$; |
| b) $z = -1 + 2i$; | k) $z = 3 - 2i$; |
| d) $z = -1 - 2i$; | l) $z = -3 + 2i$; |
| e) $z = 1 - 2i$; | m) $z = \frac{\sqrt{2}}{2}$; |
| f) $z = 2i$; | n) $z = 2 + 3i(1 + 2i)$; |
| g) $z = 1$; | o) $z = i - 4i(1 + i)$; |
| h) $z = -2i$; | p) $z = i^4 + i^5$; |
| i) $z = -1$; | q) $z = \cos \frac{\pi}{3} + i \sin \frac{\pi}{2}$. |

3.22. z kompleks songa mos keluvchi vektorni yasang:

- | | |
|--------------------|--------------------|
| a) $z = 2 + 3i$; | e) $z = -2 - 3i$; |
| b) $z = 2 - 3i$; | f) $z = 3i$; |
| d) $z = -2 + 3i$; | g) $z = -4i$; |

h) $z = 2$;

m) $z = \sqrt{4}$;

i) $z = -2$;

n) $z = \frac{1+i}{1-i}$;

j) $z = 0$;

o) $z = (1+i)(1+2i)$;

k) $z = -3 + 2i$;

p) $z = (1-i)(1+i)$;

l) $z = 3 - i$;

q) $z = i^3 - 4i$.

3.23. Kompleks son z ning modulini toping:

a) $z = 3 + 4i$;

j) $z = \cos \alpha + i \sin \alpha (\alpha \in R)$;

b) $z = -3 - 4i$;

k) $z = 1 + i \cos^2 \alpha (\alpha \in R)$;

d) $z = 1 + \sqrt{8}i$;

l) $z = (2 + 3i)(3 - 4i)$;

e) $z = 2\sqrt{2} + i$;

m) $z = \sqrt[4]{81} + 3\sqrt{2}i$;

f) $z = 3 + 3i$;

n) $z = -4$;

g) $z = 1 + 2\sqrt{3}i$;

o) $z = bi (b \in R)$;

h) $z = 1 + i$;

p) $z = i$;

i) $z = \sqrt{2} + i$;

q) $z = 0$.

3.24. z kompleks sonining argumentini toping:

a) $z = \frac{1}{\sqrt{2}} + i \frac{1}{\sqrt{2}}$;

f) $z = \frac{\sqrt{33}}{2} + i \frac{\sqrt{11}}{2}$;

j) $z = 1$;

b) $z = \frac{\sqrt{2}}{2} + i \frac{\sqrt{6}}{2}$;

g) $z = -2\sqrt{3}i$;

k) $z = i$;

d) $z = 3i$;

h) $z = -\sqrt{6} - \sqrt{6}i$;

l) $z = -1$;

e) $z = 3$;

i) $z = \frac{\sqrt{3}}{2} - \frac{1}{2}i$;

m) $z = -i$.

3.25. Kompleks sonni trigonometrik shaklda yozing:

a) $z = -1 - i$;

f) $z = -2$;

b) $z = 1 - i$;

g) $z = i$;

d) $z = \sqrt{3} + i$;

h) $z = 1$;

e) $z = -1 + \sqrt{3}i$;

i) $z = -i$;

j) $z = 1 + i$;

n) $z = 2i$;

k) $z = -\frac{1}{2} + i\frac{\sqrt{3}}{2}$;

o) $z = \frac{1}{\sqrt{2}} + i\frac{1}{\sqrt{2}}$;

l) $z = \frac{\sqrt{33}}{2} + i\frac{\sqrt{11}}{2}$;

p) $z = -i$;

m) $z = \frac{\sqrt{3}}{2} + \frac{1}{2}i$;

q) $z = -\sqrt{6} - \sqrt{6}i$.

3.26. $z = -3 - 4i$ ni trigonometrik shaklda yozing.

3.27. $z = 2 \cos \frac{7\pi}{4} - 2i \sin \frac{7\pi}{4}$ ni trigonometrik shaklda yozing.

3.28. $z = -\cos \frac{\pi}{17} + i \sin \frac{\pi}{17}$ ni trigonometrik shaklda yozing.

3.29. $z = 2 + \sqrt{3} + i$ ni trigonometrik shaklda yozing.

3.30. $z = 1 + \cos \varphi + i \sin \varphi$ ($-\pi \leq \varphi \leq \pi$) ni trigonometrik shaklda yozing.

3.31. Quyidagi sonlarni algebraik shaklda yozing:

a) $2\left(\cos \frac{\pi}{3} + i \sin \frac{\pi}{3}\right)$; b) $3\left(\cos \frac{2\pi}{3} + i \sin \frac{2\pi}{3}\right)$.

3.32. Agar $|z| = 3$ bo'lsa, z nuqtalar o'rnini aniqlang.

3.33. Har qanday z va w kompleks sonlar uchun $|z| - |w| \leq |z + w| \leq |z| + |w|$ qo'sh tengsizlikning bajarilishini isbot qiling.

3.34. Ixtiyoriy u va v kompleks sonlar uchun $|u + v|^2 + |u - v|^2$ ni toping.

3.35. Quyidagi shartlarni qanoatlantiruvchi nuqtalar to'plamini chizmada ko'rsating:

a) $|z - 10i| \leq 20$;

f) $|z - 2 + i| \leq 4$;

b) $\operatorname{Re} z > 4$;

g) $|z| = \operatorname{Re} z + 3$;

d) $\operatorname{Im} z < -1$;

h) $z\bar{z} + 4\bar{z} + 4z = 0$;

e) $|z - 2i| = 5$;

i) $\frac{|z-2|}{|z-3|} = 1$.

2. Trigonometrik shaklda berilgan kompleks sonlarni ko'paytirish, bo'lish, darajaga ko'tarish. Trigonometrik shaklda yozilgan kompleks sonlarni ko'paytirish, bo'lish va darajaga ko'tarish qoidalarini keltirib chiqarish uchun asos bo'ladigan teoremlarni qaraymiz.

1-teorema. Kompleks sonlar ko'paytmasining moduli ko'paytuvchilar modullarining ko'paytmasiga teng, ko'paytuvchilarning har qanday argumentlari yig'indisi shu kompleks sonlar ko'paytmasining biror argumenti bo'ladi.

Isbot. $z = r(\cos\varphi + i\sin\varphi)$ va $w = R(\cos\alpha + i\sin\alpha)$ lar z , w kompleks sonlarning biror trigonometrik shakli bo'lsin. U holda, z va w sonlar ko'paytmasini ko'phadlarni ko'paytirish qoidasi yordamida topsak, $zw = rR(\cos(\varphi + \alpha) + i\sin(\varphi + \alpha))$ hosil bo'ladi. Demak, $|zw| = rR = |z||w|$ va $\varphi + \alpha$ soni zw ning biror argumentidan iborat.

2-teorema. Kompleks sonlar nisbatining moduli bo'linuvchi va bo'luvchi modullarining nisbatiga teng, bo'linuvchi va bo'luvchi har qanday argumentlarining ayirmasi bo'linmaning biror argumenti bo'ladi.

Isbot. $z = r(\cos\varphi + i\sin\varphi)$ va $w = R(\cos\alpha + i\sin\alpha)$ lar z va w kompleks sonlarining biror trigonometrik shakli bo'lsin. U holda

$$\frac{z}{w} = \frac{r(\cos\varphi + i\sin\varphi)}{R(\cos\alpha + i\sin\alpha)} = \frac{r}{R}(\cos(\varphi - \alpha) + i\sin(\varphi - \alpha)) \text{ tenglik bajariladi.}$$

Bu yerdan esa $\left| \frac{z}{w} \right| = \frac{|z|}{|w|}$ ekanligi va $\varphi - \alpha$ sonning $\frac{z}{w}$ uchun argument bo'lishi kelib chiqadi.

Endi trigonometrik shaklda berilgan sonlarni ko'paytirish, bo'lish va darajaga ko'tarish qoidalarini keltiramiz.

Trigonometrik shaklda (bosh trigonometrik shaklda bo'lishi shart emas!) berilgan $z = r(\cos\varphi + i\sin\varphi)$ va $w = R(\cos\alpha + i\sin\alpha)$ kompleks sonlarni:

a) ko'paytirish uchun, $zw = rR(\cos(\varphi + \alpha) + i\sin(\varphi + \alpha))$ tenglikni tuzish va $\varphi + \alpha$ ni bosh argument bilan almashtirish;

b) bo'lish uchun, $\frac{z}{w} = \frac{r}{R}(\cos(\varphi - \alpha) + i \sin(\varphi - \alpha))$ tenglikni tuzish va $\varphi - \alpha$ ni bosh argument bilan almashtirish kerak.

Trigonometrik shaklda berilgan kompleks sonlarni ko'paytirish qoidasini $z^n = z \cdot z \cdots z$ (n ta ko'paytuvchi) ko'paytma uchun ketma-ket tatbiq etib, z^n ni hisoblash qoidasini hosil qilamiz:

$z^n = (r(\cos \varphi + i \sin \varphi))^n$ ni hisoblash uchun, $z^n = r^n(\cos n\varphi + i \sin n\varphi)$ tenglikni tuzish va $n\varphi$ argumentni bosh argument bilan almashtirish kerak.

Agar $z = \cos \varphi + i \sin \varphi$ bo'lsa, darajaga ko'tarish formulasi quyidagi ko'rinishni oladi: $(\cos \varphi + i \sin \varphi)^n = \cos n\varphi + i \sin n\varphi$.

Bu tenglik *Muavr formulasi* deyiladi.

Misol.

$$A = \frac{\left(\sqrt{2}\left(\cos\frac{\pi}{4} + i\sin\frac{\pi}{4}\right)\right)^{19} \cdot \left(2\left(\cos\frac{\pi}{4} + i\sin\frac{\pi}{4}\right)\right)^5}{\left(2\left(\cos\left(-\frac{\pi}{3}\right) + i\sin\left(-\frac{\pi}{3}\right)\right)\right)^{14} \cdot \left(2\left(\cos\left(-\frac{5\pi}{6}\right) + i\sin\left(-\frac{5\pi}{6}\right)\right)\right)^6}$$

Ifodaning qiymatini toping.

Yechish. Suratdagi ko'paytuvchilar bosh trigonometrik shakldagi, maxrajdagi ko'paytuvchilar esa bosh trigonometrik shaklda bo'lmagan kompleks sonlarning darajalaridan iborat. Bu hol amallarni bajarish qoidalarini tatbiq etishda xalaqit bermaydi.

Darajaga ko'tarish, ko'paytirish va bo'lish qoidalarini o'z o'rnida bilan qo'llash natijasida

$$A = 2^{\frac{19}{2} + 5 - 14 - 6} \cdot \left(\cos\left(\frac{19\pi}{4} + \frac{5\pi}{4}\right) - \left(-\frac{14\pi}{3}\right) - (5\pi) + i \sin\left(\frac{9\pi}{4} + \frac{5\pi}{4}\right) - \left(-\frac{14\pi}{3}\right) - (-5\pi)\right) = 2^{-\frac{11}{2}} \left(\cos\frac{185\pi}{12} + i \sin\frac{185\pi}{12}\right)$$

tenglikni hosil qilamiz. Bu tenglikning o'ng tomoni kompleks sonning bosh trigonometrik shaklini ifodalamaydi, chunki

$$\frac{185\pi}{12} > 2\pi.$$

$\frac{185\pi}{12}$ ni bosh argument bilan almashtiramiz:

$$A = 2^{-\frac{11}{2}} \left(\cos \left(14\pi + \frac{17\pi}{12} \right) + i \sin \left(14\pi + \frac{17\pi}{12} \right) \right) =$$

$$= 2^{-\frac{11}{2}} \left(\cos \frac{17\pi}{12} + i \sin \frac{17\pi}{12} \right).$$



M a s h q l a r

3.36. Trigonometrik shaklda berilgan sonlarning ko'paytmasini toping:

- a) $z_1 = \frac{\sqrt{2}}{2} \left(\cos \frac{\pi}{4} + i \sin \frac{\pi}{4} \right)$ va $z_2 = \cos \frac{\pi}{8} + i \sin \frac{\pi}{8}$;
- b) $z_1 = \frac{1}{2} \left(\cos \frac{\pi}{15} + i \sin \frac{\pi}{15} \right)$ va $z_2 = 4 \left(\cos \frac{\pi}{9} + i \sin \frac{\pi}{9} \right)$;
- d) $z_1 = \sqrt{3} \left(\cos \frac{\pi}{24} + i \sin \frac{\pi}{24} \right)$ va $z_2 = 3 \left(\cos \frac{\pi}{12} + i \sin \frac{\pi}{12} \right)$;
- e) $z_1 = 5 \left(\cos \pi + i \sin \pi \right)$ va $z_2 = \cos \frac{\pi}{3} + i \sin \frac{\pi}{3}$.

3.37. $\frac{z_1}{z_2}$ ni hisoblang:

- a) $z_1 = \sqrt{3} \left(\cos \frac{\pi}{19} + i \sin \frac{\pi}{19} \right)$, $z_2 = 2 \left(\cos \frac{\pi}{21} + i \sin \frac{\pi}{21} \right)$;
- b) $z_1 = 9 \left(\cos \frac{\pi}{4} + i \sin \frac{\pi}{4} \right)$, $z_2 = 9 \left(\cos \frac{\pi}{3} + i \sin \frac{\pi}{3} \right)$;
- d) $z_1 = \cos \frac{\pi}{4} + i \sin \frac{\pi}{4}$, $z_2 = \cos \frac{\pi}{6} + i \sin \frac{\pi}{6}$;
- e) $z_1 = \frac{1}{3} \left(\cos \frac{3\pi}{2} + i \sin \frac{3\pi}{2} \right)$, $z_2 = \frac{1}{3} \left(\cos \frac{5\pi}{6} + i \sin \frac{5\pi}{6} \right)$.

3.38. Darajani hisoblang:

- a) $\left(2 \left(\cos \frac{\pi}{21} + i \sin \frac{\pi}{21} \right) \right)^7$;
- b) $\left(\sqrt{3} \left(\cos \frac{\pi}{9} + i \sin \frac{\pi}{9} \right) \right)^{18}$;
- d) $\left(\sqrt{4} \left(\cos \frac{\pi}{3} + i \sin \frac{\pi}{3} \right) \right)^6$;
- e) $\left(3 \left(\cos \frac{\pi}{13} + i \sin \frac{\pi}{13} \right) \right)^2$;
- f) $\left(\cos \frac{3\pi}{2} + i \sin \frac{3\pi}{2} \right)^{20}$;
- g) $\left(\cos \frac{\pi}{21} + i \sin \frac{\pi}{21} \right)^{16}$;

$$h) \left(\cos \frac{\pi}{9} + i \sin \frac{\pi}{9} \right)^{15};$$

$$i) \left(\cos \frac{\pi}{7} + i \sin \frac{\pi}{7} \right)^{17}.$$

1.39. Muavr formulasidan foydalanib, ifodalarni $\cos \varphi$ va $\sin \varphi$ orqali ifodalang:

1) $\cos 8\varphi$; 2) $\sin 8\varphi$; 3) $\cos 9\varphi$; 4) $\sin 9\varphi$.

1.40. $\frac{1}{1+z}$ ni hisoblang, bunda $z = \cos \varphi + i \sin \varphi$.

1.41. Quyidagi ifodalarni hisoblang:

$$a) \frac{(1-i)^9(\sqrt{2}+i)^6}{(1+i)(1-i\sqrt{2})^6}; \quad b) \frac{(1-i)^{11}(-\sqrt{2}-i)^8}{(1-i)^{11}}; \quad d) \frac{(1-i)^{148}}{(1+i)^{102} - (1-i)^{102}i}.$$

1.42. $(1 - \cos \varphi + i \sin \varphi)^{12}$ ni hisoblang.

3. Kompleks sondan ildiz chiqarish. z kompleks sonning n -darajali ildizi deb, $w^n = z$ tenglik bajariladigan har qanday w kompleks songa aytiladi (bu yerda $n \in \mathbb{N}$).

Agar $z = 0$ bo'lsa, $w^n = 0$ ($n \in \mathbb{N}$) tenglik $w = 0$ soni uchungina bajariladi.

Agar $z \neq 0$ bo'lsa, $w^n = z$ ($n \in \mathbb{N}$) tenglik w ning n ta har xil kompleks ildizlarga ega bo'lishini isbotlaymiz.

T e o r e m a. $z = r(\cos \alpha + i \sin \alpha) \neq 0$ kompleks soni n ta har xil w_k kompleks ildizlarga ega va bu ildizlar quyidagi formula bilan topiladi:

$$w_k = \sqrt[n]{r} \left(\cos \frac{\alpha + 2\pi k}{n} + i \sin \frac{\alpha + 2\pi k}{n} \right), \quad k = 0, 1, 2, \dots, n-1.$$

I s b o t. $w = R(\cos \varphi + i \sin \varphi)$ kompleks soni ($z = r \cos \alpha + i \sin \alpha) \neq 0$ sonning n -darajali ildizi bo'lsin. U holda $R^n(\cos n\varphi + i \sin n\varphi) = r(\cos \alpha + i \sin \alpha)$ tenglik o'rinli bo'ladi. Ikki kompleks sonning modullari teng va argumentlari bir-biridan $2\pi k$ (bu yerda $k \in \mathbb{Z}$) qo'shiluvchiga farq qilsagina, ular teng bo'ladi. Shu sababli

$$R = \sqrt[n]{r}, \quad (1)$$

$$\varphi = \frac{\alpha + 2k\pi}{n}, \quad k \in Z \quad (2)$$

tengliklar bajariladi. Hosil qilingan bu tengliklarni w ning trigonometrik shakliga qo'yamiz:

$$w = \sqrt[n]{r} \left(\cos \frac{\alpha + 2\pi k}{n} + i \sin \frac{\alpha + 2\pi k}{n} \right), \quad k \in Z. \quad (3)$$

Bu yerdan ko'rinadiki, $z = r(\cos \alpha + i \sin \alpha)$ kompleks sonining har qanday n -darajali ildizi (3) ko'rinishda bo'ladi. Aksincha, (3) ko'rinishdagi har qanday kompleks son $z = r(\cos \alpha + i \sin \alpha)$ kompleks sonining n -darajali ildizi bo'ladi. Buni darajaga ko'tarish yordamida bevosita tekshirib ko'rish mumkin.

Shunday qilib, (3) ko'rinishdagi sonlar va faqat shu sonlarga $z = r(\cos \alpha + i \sin \alpha)$ kompleks sonining n -darajali ildizi bo'ladi.

Endi (3) formula $z \in 0$ sonining n ta har xil ildizini aniqlashini ko'rsatamiz. Qulaylik uchun (3) formuladagi w ning k ga bog'liq ekanligini oshkor ko'rinishda yozib olaylik:

$$w_k = \sqrt[n]{r} \left(\cos \frac{\alpha + 2\pi k}{n} + i \sin \frac{\alpha + 2\pi k}{n} \right), \quad k \in Z. \quad (4)$$

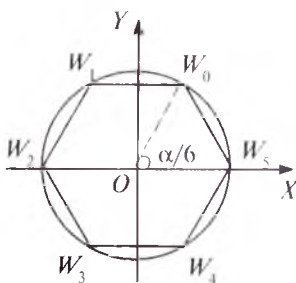

20- rasm.

$k = 0, k = 1, \dots, k = n - 1$ bo'lganda bu formula yordamida w_0, w_1, \dots, w_{n-1} sonlari hosil qilinadi. Bu sonlarning argumentlari bir-biridan 2π ga *kar-rali bo'lmagan* qo'shiluvchi bilan farq qiladi. Shuning uchun bu sonlar orasida tenglari mavjud bo'lmaydi, ya'ni ular n tadir.

Endi ixtiyoriy $k \in Z$ sonini $n \in \mathbb{N}$ soniga qoldiqli bo'lamiz:

$$k = n \cdot m + s, \quad \text{bu yerda } m \in Z, s \in \{0, 1, 2, \dots, n - 1\}.$$

U holda,

$$w_k = \sqrt[n]{r} \left(\cos \frac{\alpha + 2(nm+s)\pi}{n} + i \sin \frac{\alpha + 2(nm+s)\pi}{n} \right) = \\ = \sqrt[n]{r} \cdot \left(\cos \frac{\alpha + 2s\pi}{n} + i \sin \frac{\alpha + 2s\pi}{n} \right) = w_s.$$

Bu yerdan ko'rinadiki, (4) formuladagi k ning o'rniga har qanday butun son qo'yilganda ham, w_0, w_1, \dots, w_{n-1} sonlardan biortasi hosil bo'ladi. Teorema isbot bo'ldi.

Markazi koordinatalar boshida bo'lgan $\sqrt[n]{r}$ radiusli aylanani qaraymiz. W_0, W_1, \dots, W_{n-1} nuqtalar shu aylanada yotadi va uni n ta teng yoylarga ajratadi, chunki qo'shni W_k nuqtalarning argumentlari bir-birlaridan $\frac{2\pi}{n}$ ga farq qiladi. Demak, bu nuqtalar aylanaga ichki chizilgan muntazam n burchakning uchlari bo'ladi (20-rasmda bu muntazam oltiburchak, chizmada $n=6$, $\angle W_0OW_5 = \frac{\alpha}{6}$).

1-misol. $\sqrt[3]{-\sqrt{2} + i\sqrt{2}}$ ning barcha w_k qiymatlarini topamiz.

Yechish. $(-\sqrt{2} + i\sqrt{2}) = \sqrt{(-\sqrt{2})^2 + (\sqrt{2})^2} = 2,$

$$\alpha = \arg(-\sqrt{2} + i\sqrt{2}) = \frac{3\pi}{4}$$

bo'lgani uchun $-\sqrt{2} + i\sqrt{2} = 2 \left(\cos \frac{3\pi}{4} + i \sin \frac{3\pi}{4} \right)$ ga egamiz.

(3) formulaga ko'ra w_k qiymat uchun

$$w_k = \sqrt[3]{2} \left(\cos \frac{\frac{3\pi}{4} + 2\pi k}{3} + i \sin \frac{\frac{3\pi}{4} + 2\pi k}{3} \right), \quad k = 0, 1, 2$$

tenglikka ega bo'lamiz. Bu tenglikdan quyidagilarni aniqlaymiz:

$$k=0 \text{ da } w_0 = \sqrt[3]{2} \left(\cos \frac{\pi}{4} + i \sin \frac{\pi}{4} \right) = \frac{\sqrt[6]{2^5}}{2} (1 + i),$$

$$k = 1 \text{ da } w_1 = \sqrt[3]{2} \left(\cos \frac{11\pi}{12} + i \sin \frac{11\pi}{12} \right) = \\ = \frac{\sqrt[3]{2}}{4} \left(-\sqrt{6} - \sqrt{2} + i(\sqrt{6} - \sqrt{2}) \right),$$

$$k = 2 \text{ da } w_2 = \sqrt[3]{2} \left(\cos \frac{19\pi}{12} + i \sin \frac{19\pi}{12} \right) = \\ = \sqrt[3]{2} \left(\sin \frac{\pi}{12} + i \cos \frac{\pi}{12} \right) = \frac{\sqrt[3]{2}}{4} \left(\sqrt{6} - \sqrt{2} + i(\sqrt{6} + \sqrt{2}) \right).$$

2- m i s o l. 1) $z^2 + 4 = 0$; 2) $z^4 - 16 = 0$; 3) $z^3 - 1 = 0$; 4) $z^3 + 1 = 0$; 5) $z^5 - 1 = 0$ tenglamalarni yeching.

Y e c h i s h. Tenglamalarni yechishda ko'phadlarni birinchi va ikkinchi darajali ko'paytuvchilarga ajratishdan foydalanamiz:

$$1) z^2 + 4 = (z - 2i)(z + 2i) = 0, \text{ bundan } z_1 = 2i; z_2 = -2i;$$

$$2) z^4 - 16 = (z^2 - 4)(z^2 + 4) = 0 \Rightarrow (z - 2)(z + 2)(z + 2i)(z - 2i) = 0, \text{ bundan } z_{1,2} = \pm 2, z_{3,4} = \pm 2i;$$

$$3) z^3 - 1 = (z - 1)(z^2 + z + 1) = 0 \Rightarrow \begin{cases} z - 1 = 0 \\ z^2 + z + 1 = 0 \end{cases} \Rightarrow$$

$$\Rightarrow \begin{cases} z_1 = 1, \\ z_{2,3} = \frac{-1 \pm i\sqrt{3}}{2}; \end{cases}$$

$$4) z^3 + 1 = (z + 1)(z^2 - z + 1) = 0, \text{ bundan } z_1 = -1, \\ z_{2,3} = \frac{1 \pm i\sqrt{3}}{2};$$

5) $z^5 - 1 = (z - 1)(z^4 + z^3 + z^2 + z + 1) = 0$; $z - 1 = 0$ bo'yicha $z_1 = 1$, shu kabi

$$z^4 + z^3 + z^2 + z + 1 = 0 \Rightarrow \frac{z^4}{z^2} + \frac{z^3}{z^2} + \frac{z^2}{z^2} + \frac{z}{z^2} + \frac{1}{z^2} = 0 \Rightarrow \\ \Rightarrow \left(z^2 + \frac{1}{z^2} \right) + \left(z + \frac{1}{z} \right) + 1 = 0.$$

Agar $z + \frac{1}{z} = t, z^2 + 2 + \frac{1}{z^2} = t^2$ yoki $z^2 + \frac{1}{z^2} = t^2 - 2$

almashtirish kiritilsa, $t^2 + t - 1 = 0$ tenglama hosil bo'ladi. Uning

ildizlari $t_{1,2} = \frac{-1 \pm \sqrt{5}}{2}$. U holda:

$$z + \frac{1}{z} = \frac{-1 + \sqrt{5}}{2}, \text{ bundan } z_{2,3} = \frac{-1 + \sqrt{5} \pm i\sqrt{10 + 2\sqrt{5}}}{4},$$

$$z + \frac{1}{z} = \frac{-1 - \sqrt{5}}{2}, \text{ bundan } z_{4,5} = \frac{-1 - \sqrt{5} \pm i\sqrt{10 - 2\sqrt{5}}}{4}.$$

3- misol. $z^6 - 28z^3 + 27 = 0$ tenglamani yechamiz.

Yechish. $z^3 = u$ almashtirish berilgan tenglamani $u^2 - 28u + 27 = 0$ kvadrat tenglamaga keltiradi. Uning ildizlari 1 va 27. Endi

$z^3 = 1$ va $z^3 = 27$ tenglamalarni yechib, javobni topamiz:

$$z_1 = 1, z_{2,3} = \frac{-1 \pm \sqrt{3}}{2}, z_4 = 3, z_{5,6} = \frac{-3 \pm 3\sqrt{3}i}{2}.$$



Mashqlar

3.43. \sqrt{z} ni hisoblang:

a) $z = \frac{\sqrt{2}}{2} \left(\cos \frac{\pi}{4} + i \sin \frac{\pi}{4} \right);$ d) $z = \cos \frac{\pi}{3} + i \sin \frac{\pi}{3};$

b) $z = \frac{1}{2} \left(\cos \frac{\pi}{15} + i \sin \frac{\pi}{15} \right);$ e) $z = \cos \frac{\pi}{6} + i \sin \frac{\pi}{6}.$

3.44. $z = 16 \left(\cos \frac{\pi}{3} + i \sin \frac{\pi}{3} \right)$ sonining uchinchi va to'rtinchi darajali ildizlarini toping.

3.45. $x^5 = r(\cos \varphi + i \sin \varphi)$ tenglamaning barcha ildizlari ko'paytmasini toping.

3.46. Kvadrat tenglamalarni yeching:

a) $x^2 + 8ix + 12 = 0;$

b) $x^2 + \sqrt{15}ix + 51,5 = 0;$

$$d) x^2 - 10ix + 24 = 0.$$

3.47. Ikki hadli tenglamalarni yeching:

$$a) 27z^3 - 8 = 0; \quad d) z^5 + 243 = 0;$$

$$b) z^{18} - 1 = 0; \quad e) z^{10} - 59\,049 = 0.$$

3.48. $z^8 - 12z^4 + 11 = 0$ uch hadli tenglamani yeching.

3.49. $z^{12} - 65z^6 + 64$ tenglamani yeching.



Takrorlashga doir mashqlar

3.50. Hisoblang:

$$a) (2 + 3i)(4 - 5i) + (2 - 3i)(4 + 5i);$$

$$b) (x - 1 - i)(x - 1 + i)(x + 1 + i)(x + 1 - i), \quad x \in \mathbb{R};$$

$$d) \frac{(1 + 2i)^2}{1 - 3i};$$

$$e) (1 - 4i) - (i(3 - 4i) + 3i);$$

$$f) (1 + 4i)^2 - (3 + i^9);$$

$$g) 3 + 8i + 9i^2 + 10i^3;$$

$$h) 8 - 4(i^{15} - 1) + 13i;$$

$$i) 21i^4 + 23i^{91} - 17i^{17}.$$

3.51. Tenglamani yeching (bunda $x \in \mathbb{R}$):

$$a) -2x + 4i = 3x\left(\frac{1}{3} + i^2\right) + 2i - 2i^2;$$

$$b) 3 + xi = \left(\frac{18}{9} + x\right) + 1 + i;$$

$$d) 5 + (3 + x)i = 3x + 2 + 4i;$$

$$e) x + 5 - (3 + x^2)i = 7 - 7i.$$

3.52. Agar $(5x - 3y) + (x - 2y)i = 6 + (8 - x + y)i$ bo'lsa, x , y haqiqiy sonlarni toping.

3.53. Daraja asosini trigonometrik shaklda yozmasdan darajani hisoblang:

a) $(1 + i)^{20}$; b) $(1 - i)^{21}$.

3.54. Quyidagilarni $\sin x$ va $\cos x$ orqali ifodalang:

a) $\sin 3x$; b) $\cos 3x$; d) $\sin 4x$; e) $\cos 4x$; f) $\sin 5x$;
g) $\cos 5x$; h) $\sin 2x$.

3.55. Kompleks sonlarni trigonometrik shaklda yozib, hisoblashlarni bajaring:

a) $(1 + i)^{26}$;

f) $(1 + i)^9(1 - i)^{15}$;

b) $\left(\frac{1 + i\sqrt{3}}{1 + i}\right)^{20}$;

g) $(1 + 2i)^8(2 + 3i)^4$;

d) $\left(1 - \frac{\sqrt{3} - i}{2}\right)^{24}$;

h) $(2 + i)^{26}(2 + 3i)^9$;

e) $\left(\frac{-1 + i\sqrt{3}}{(1 - i)^{20}}\right)^{20}$;

i) $\left(\frac{-1 - i\sqrt{3}}{(1 - i)^{21}}\right)^{15}$.

3.56. $\sqrt[n]{z}$ ni hisoblang:

a) $z = 1$, $n = 3$;

h) $z = -9$, $n = 3$;

b) $z = -1$, $n = 4$;

i) $z = -15$, $n = 4$;

d) $z = -4 + \sqrt{48}i$, $n = 3$;

j) $z = \frac{\sqrt{2}}{2} + \frac{\sqrt{2}}{2}i$, $n = 3$;

e) $z = 1 + i$, $n = 8$;

k) $z = 1 - i$, $n = 6$;

f) $z = i$, $n = 3$;

l) $z = 5i$, $n = 2$;

g) $z = -i$, $n = 3$;

m) $z = -9i$, $n = 2$.

3.57. Tenglamani yeching:

a) $z^4 - 1$; b) $z^3 = 1 + i$; d) $z^2 = -9$; e) $z^2 = 16$.

3.58. a) $ax^2 + bx + c = 0$ ($a \neq 0$) tenglamada $b^2 - 4ac < 0$. Tenglamani kompleks sonlar to'plamida yeching.

b) $z^4 + z^2 + 1 = 0$ tenglamani yeching.

3.59. Hisoblang:

a) $\sqrt[3]{\frac{1-i}{\sqrt{3}+i}}$; d) $\sqrt[4]{\frac{1+i}{\sqrt{3}-i}}$;

b) $\sqrt[5]{\frac{1-i}{1+i\sqrt{3}}}$; e) $\sqrt[6]{\frac{1+i}{1-i\sqrt{3}}}$;

3.60. Tenglamadan x va y ni toping ($x \in R, y \in R$):

a) $(x - y) + (3x + y)i = 3 - 3i$;

b) $(5x + 3yi) + (2y - xi) = 3 - i$;

d) $(\frac{3}{4}x - 2yi) - (\frac{1}{3}y + 6xi) = 21i$;

e) $(2 - 3i)(x + yi) = -1 - 5i$.

3.61. Berilgan kompleks sonlarni qo'shing. Qo'shiluvchilarning va yig'indining geometrik tasvirini yasang:

a) $(2 + 3i) + (4 + 2i)$;

f) $(-4 - 7i) + (4 + 7i)$;

b) $(-4 + 5i) + (3 - 2i)$;

g) $(-3 + 2i) + (3 - 2i)$;

d) $(-7 + 6i) + (-3 - 8i)$;

h) $3i + (4 - 5i)$;

e) $(-5 - 2i) + (-6 + 8i)$;

i) $4i + (-8i)$.

3.62. Ayirishni bajaring. Kamayuvchi, ayriluvchi va ayirmaning geometrik tasvirini yasang:

a) $(3 + 2i) - (2 - 2i)$;

e) $(4 - 2i) - (3 + 3i)$;

b) $i - 5i$;

f) $8 - (4 - 3i)$;

d) $(4 + 3i) - (2 - 3i)$;

g) $i - (2 - 3i)$.

3.63. Bo'lishni bajaring:

a) $6(\cos 70^\circ + i \sin 70^\circ) : 3(\cos 25^\circ + i \sin 25^\circ)$;

b) $2(\cos 120^\circ + i \sin 120^\circ) : 4(\cos 90^\circ + i \sin 90^\circ)$;

d) $\sqrt{6}(\cos 160^\circ + i \sin 160^\circ) : \sqrt{3}(\cos 40^\circ + i \sin 40^\circ)$;

e) $4(\cos 75^\circ + i \sin 75^\circ) : \frac{1}{2}(\cos(-15^\circ) + i \sin(-15^\circ))$;

f) $8i + (1 + \sqrt{3}i)$;

g) $-6i + (-4 - 4i)$;

h) $(6 - 6i) : 3(\cos 15^\circ + i \sin 15^\circ)$;

i) $(2 + 2\sqrt{3}i) : (4 - 4i)$.

3.64. Ko'paytuvchilarga ajrating:

a) $x^2 + 4$; b) $x^4 - 16$; d) $x^2 + 3 - 4i$; e) $7 + \sqrt{5}$.

3.65. Tenglikni tekshiring:

a) $\left(\frac{-1+i\sqrt{3}}{2}\right)^4 + \left(\frac{-1-i\sqrt{3}}{2}\right)^4 = 1$;

b) $\left(\frac{1-i}{\sqrt{2}}\right)^5 + \left(\frac{1+i}{\sqrt{2}}\right)^5 = -\sqrt{2}$;

d) $\left(\frac{-\sqrt{3}+i}{2}\right)^5 + \left(\frac{-\sqrt{3}-i}{2}\right)^5 = \sqrt{3}$;

e) $\left(\frac{1+i}{1-i}\right)^3 - \left(\frac{1-i}{1+i}\right)^3 = 2$.

3.66. Kompleks tekislikda quyidagi shartni qanoatlantiruvchi nuqtalarning geometrik o'rnini shtrixlang:

a) $\operatorname{Re}(z) < 5$;

h) $|z| > 5$;

b) $\frac{\pi}{4} < \arg(z) < \frac{\pi}{3}$;

i) $1 < |z| < 3$;

d) $\operatorname{Re}(z) = 2$;

j) $|z - 4| < 2$;

e) $\operatorname{Im}(z) = -2$;

k) $|z + 2i| \geq 4$;

f) $\operatorname{Re}(z) < 0$;

l) $|z + 1 - i| < 2$;

g) $\operatorname{Re}(z) + \operatorname{Im}(z) = 0$;

m) $|z - i| < |z - 1|$.

3.67. $z = (p + qi)(p - qi)$ kompleks sonning modulini toping ($p \in R, q \in R$).

3.68. $z_1 = -2 + 2\sqrt{3}i$ va $z_2 = 1 - i$ sonlarni trigonometrik shaklga keltirib, quyidagi ifodalarni hisoblang:

a) $z_1 \cdot z_2$; d) $\frac{z_1^3}{z_2}$; f) $\sqrt[4]{z_1}$; h) $z_1^2 \cdot z_2$;

b) $\frac{z_2}{z_1}$; e) z_2^6 ; g) $\sqrt[3]{z_2}$; i) $z_1 \cdot z_2^2$.

3.69. Quyidagi tengliklarni isbotlang:

a) $z \cdot \bar{z} = |z|^2$; d) $z + \bar{z} = 2 \operatorname{Re}(z)$;

b) $\overline{z_1 + z_2} = \bar{z}_1 + \bar{z}_2$; e) $z - \bar{z} = 2 \operatorname{Im}(z) \cdot i$.

3.70. a) Tekislikda $z_1 = 3 + 2i$ va $z_2 = 5 - i$ kompleks sonlarga mos $M_1(3; 2)$ va $M_2(5; -1)$ nuqtalar yasalgan. $z_3 = 2(z_1 + z_2)^2$ songa mos nuqta tekislikning qanday $M_3(x_3; y_3)$ nuqtasida joylashadi?

b) Parallelogrammning uchta uchi $z_1 = 0$, $z_2 = 2 + 0,5i$, $z_3 = 0,7 + 1,8i$ kompleks sonlarga mos nuqtalarda joylashgan. Parallelogrammning to'rtinchi uchiga mos z_4 kompleks sonni toping.



IV bob

KO'PHADLAR

1- §. Birhadlar va ko'phadlar

1. Algebraik ifoda. Natural ko'rsatkichli daraja. Birhad.

Algebrada qo'llaniladigan harfiy belgilashlar bir xil turdagi ko'plab masalalarni formulalar ko'rinishida berilgan umumiy qoida asosida yechishga imkoniyat yaratadi. Agar sonli ifodadagi ayrim yoki barcha sonlar harflar bilan almashtirilsa, *harfiy ifoda* hosil bo'ladi. Biz harfiy ifodalashdan matematika, fizika va boshqa fanlarni o'rganishda keng foydalanamiz.

To'rt matematik amal, butun darajaga ko'tarish va butun ko'rsatkichli ildiz chiqarish ishoralari orqali birlashtirilgan harflar va sonlardan iborat ifodalar *algebraik ifoda* deyiladi. Agar algebraik ifodada sonlar va harflarning ildiz ishoralari qatnashmasa, u *ratsional algebraik ifoda*, ildiz ishoralari qatnashsa, *irratsional algebraik ifoda* deyiladi. Agar ratsional ifodada harfli ifodaga bo'lish amali qatnashmasa, u *butun algebraik ifoda* deyiladi.

Misol(lar). 1) $6b - 3a + dc$ — butun algebraik ifoda;

2) $\frac{bc+a}{c}$ — kasr algebraik ifoda;

3) $5 + \sqrt{c}$ — irratsional algebraik ifoda;

4) $(a-b)^2 = (b-a)^2$ — ayniyat.

Irratsional ifoda biror ratsional ifodaga aynan teng bo'lishi ham mumkin. Masalan, $\sqrt{(a^2+2)^2-2} = a^2$. Algebraik ifodalarni shakl almashtirishlar haqida V bobda alohida to'xtalamiz.

Har biri a ga teng bo'lgan n ($n \geq 2$) ta ko'paytuvchining ko'paytmasi a sonining n -darajasi deyiladi va a^n deb belgilanadi. Shunday qilib,

$$a^n = \underbrace{a \cdot a \cdot \dots \cdot a}_{n \text{ marta}} \quad (n \geq 2).$$

Ta'rifga asosan $a^1 = a$. Natural ko'rsatkichli darajaning xossalari:

$$1^\circ. a^m \cdot a^n = a^{m+n}; m, n \in N.$$

$$2^\circ. a^m : a^n = a^{m-n}; m, n \in N, m > n.$$

$$3^\circ. (a^m)^n = a^{mn}; m, n \in N.$$

$$4^\circ. (ab)^n = a^n b^n; n \in N.$$

$$5^\circ. \left(\frac{a}{b}\right)^n = \frac{a^n}{b^n}; a, b \in R, b \neq 0, n \in N.$$

3°-xossani isbotlaymiz (qolgan xossalari ham shu kabi isbotlanadi):

$$(a^m)^n = \underbrace{a^m \cdot a^m \cdot \dots \cdot a^m}_{n \text{ marta}} = \underbrace{a \cdot \dots \cdot a}_{m \text{ marta}} \cdot \underbrace{a \cdot \dots \cdot a}_{m \text{ marta}} \cdot \dots \cdot \underbrace{a \cdot \dots \cdot a}_{m \text{ marta}} \dots =$$

$$= \underbrace{a \cdot a \cdot \dots \cdot a}_{mn \text{ marta}} = a^{mn}.$$

Butun musbat darajali harf, son yoki ulardan tuzilgan ko'paytuvchilar ko'paytmasidan iborat butun algebraik ifoda *birhad* deyiladi. Koeffitsiyentlari bilangina farq qiladigan birhadlar *o'xshash birhadlar* deyiladi. Masalan, $3ab$ va $-4,2ab$ lar o'xshash birhadlardir.

Har qanday birhad turli ko'rinishda yozilishi mumkin. Masalan, $7a^6 \cdot b^5 = 3,5 \cdot 2a^6 \cdot b^5 = 7a^4 \cdot b^3 \cdot a^2 \cdot a^2 \cdot b^2 = \dots$

Lekin $7a^6b^5$ birhadida sonli ko'paytuvchi birinchi o'rinda, harflar alfavit tartibida daraja ko'rsatkichi orqali bir marta yozilgan bo'lib, u *standart (kanonik)* ko'rinishda yozilgandir.

Birhaddagi barcha harflar darajalarining yig'indisi shu birhadning *darajasi* deyiladi.

Son yoki bitta harf ham birhaddir. Masalan, x ; y ; $\frac{3}{4}$; 0 ; $3, (9)$ — birhadlardir.

M a s h q l a r

4.1. Ifodani x asosli daraja ko'rinishida yozing:

- | | | |
|--------------------------------|--------------------------|---------------------------------------|
| a) $x^3 \cdot x^5$; | f) $(x^2)^3$; | j) $x^3 \cdot x^4(a^b \cdot N)$. |
| b) $x^4 \cdot x^5 \cdot x^6$; | g) $(x^3)^2$; | k) $(x^2 \cdot x^3)^4(a^b \cdot N)$. |
| d) $-x^3 \cdot x^4$; | h) $(x^2 \cdot x^4)^3$; | l) $x^2 \cdot (x^3)^4$; |
| e) $-x^3 \cdot x^3$; | i) $((x^3)^4)^5$; | m) $(x^4)^2 \cdot (x^2)^4$. |

4.2. Ifodaning qiymatini toping:

- | | |
|--|--|
| a) $\frac{2^5 \cdot 11^8}{22^{10}} \cdot \frac{34^4 \cdot 2^{10}}{17^5 \cdot 8^4}$; | f) $\frac{12^8}{2^3 \cdot 3^4} \cdot \frac{10}{2^6 \cdot 5^2}$; |
| b) $\frac{2^8 \cdot 7^9}{14^{10}} \cdot \frac{26^5}{13^6 \cdot 8^4}$; | g) $\frac{12^5}{2^3 \cdot 3^4} \cdot \frac{10^5}{2^6 \cdot 5^2}$; |
| d) $\frac{14^{10}}{2^8 \cdot 7^9} \cdot \frac{13^6 \cdot 8^4}{26^5}$; | h) $\frac{10^5}{2^6 \cdot 5^7} \cdot \frac{12^5}{2^3 \cdot 3^4}$; |
| e) $\frac{12^5}{2^3 \cdot 4^4}$; | i) $\frac{10^5}{2^7 \cdot 5^6} \cdot \frac{2^4 \cdot 3^5}{12^5}$. |

4.3. Birhadning darajasini aniqlang:

- | | |
|--------------------|--|
| a) $3x^4xy^5$; | h) $13yz^{15}$; |
| b) $-31xy^4$; | i) $43x^2y^3z^{19}$; |
| d) $0.8x^2y^2$; | j) 15 ; |
| e) 15 ; | k) x^4y^2z ; |
| f) $3xy^9z$; | l) $x \cdot x^2 \cdot \dots \cdot x^9$; |
| g) $14x^2y^3z^4$; | m) $xyx^2y^2x^4y^4x^6y^6 \cdot \dots \cdot x^{20}y^{20}$. |

4.4. Birhadni standart shaklga keltiring:

- | | |
|------------------------------|--|
| a) $13xy \cdot 14x^2y^3$; | f) $3xy(-1.5)y^3$; |
| b) $x^2y^2xz^4$; | g) $\frac{2}{3}ax^3y^2 \cdot 6.5x^3$; |
| d) $3x^2z^2y^2 \cdot xz^5$; | h) $a \cdot xy^2z \cdot y^4 \cdot x^5$; |
| e) $11x^2y \cdot 13x^3y^4$; | i) $a(x^2)^3yz^2x^3$. |

4.5. A^n ni toping:

- a) $A = 3x^2yz$, $n = 3$; f) $A = 2x^2yz^2$, $n = 4$;
 b) $A = 13xy^2$, $n = 2$; g) $A = 3xz^4$, $n = 5$;
 d) $A = x^2y^4z$, $n = 14$; h) $A = 4y^2z^3$, $n = 4$;
 e) $A = 41xyz^2$, $n = 3$; i) $A = 14xy^3z^3$, $n = 2$.

4.6. Birhadning koeffitsiyentini aniqlang:

- a) $1,5xy^2\left(\frac{2}{3}\right)x^2$; f) $1,(51)x^2yz^2 \cdot \frac{3}{4}xy$;
 b) $\frac{4}{7}xz \cdot \frac{13}{8}x^2y$; g) $1\frac{3}{7}xy^2 \cdot \frac{4}{10}z^2$;
 d) $\frac{14}{15}x \cdot \frac{15}{28}y \cdot 2y^3$; h) $\frac{11}{13}x^2y^3z$;
 e) $0,(3)xy \cdot \frac{1}{9}z$; i) $\frac{13}{14}xy \cdot \frac{17}{13}z^2$.

4.7. Ifodani soddalashtiring:

- a) $(13a + 15b) - (14a - 7b)$;
 b) $(11x^3 - 12x^2) + (x^3 - x^2 + x^4)$;
 d) $(3a^2x - 11x^2) - (3a^2x + 6x^2)$;
 e) $(4x^2y + 8xy) - (3x^2y - 5xy)$;
 f) $(23x - 11y + 10a) - (-15x + 10y - 15a)$;
 g) $(7a^2 - 5ax - x^2) + (-2a^2 + ax - 2x^2)$;
 h) $(13x^2 - 8xy - y^2) + (-11x^2 - 9xy)$;
 i) $(11xy + 13y^2) - (9xy + x^2)$.

4.8. Amallarni bajaring:

- a) $a(a^2 + x) - x(a - x)$;
 b) $13(x^2 + y) + 5(x^2 - y)$;
 d) $2(a - 3x) + 3(a - 2x)$;
 e) $13(2a - 3x) + 11(a + x)$;
 f) $-3(a^2 - x^2) - 2(a^2 + x^2)$;
 g) $-(3a - 2x) + 5(a - 2x)$;
 h) $17(x^2 - y^2) - 15(y^2 - x^2)$;
 i) $19(x^3y - xz^2) + 17(-x^3y + xz^2)$.

4.9. Ifodani soddalashtiring va o'zgaruvchining ko'rsatilgan qiymatida ifoda qiymatini toping:

a) $(a - 4)(a - 2) - (a - 1)(a - 3)$; $a = 1,75$;

b) $(2a - 5)(a + 1) - (a + 2)(a - 3)$; $a = -2,6$;

d) $(a - 5)(a - 1) + (a - 2)(a - 3)$; $a = 1,3$;

e) $(x + 1)(x + 2) + (x + 3)(x + 4)$; $x = -0,4$.

2. Ko'phadlar. Birhadlar yig'indisi *ko'phad* deyiladi.

Masalan, $3a^2b + 7b^2c$, $9x^2y + xy^2$ ifodalarning har biri ko'phaddir.

Ko'phad tarkibidagi eng katta darajali birhadning darajasi shu *ko'phadning darajasi* deyiladi. Masalan, $P(x) = c + ax^2 + bx$, $R(x, y) = 3xy + z$ ikkinchi darajali ko'phaddir.

$P(x) = c + ax^2 + bx$ va $P(x) = ax^2 + bx + c$ ko'phadlarni qaraylik, ular bitta ko'phadning ikki ko'rinishli yozuvi. Ulardan ikkinchisi x o'zgaruvchi daraja ko'rsatkichlarining kamayib borishi tartibida, ya'ni *standart* ko'rinishdagi yozuvdir. Ko'p argumentli ko'phadlar ham standart ko'rinishda yozilishi mumkin. x, y, \dots, z o'zgaruvchilar, a, b lar noldan farqli sonlar bo'lsin. $ax^{k_1}y^{k_2} \dots z^{k_n}$ va $bx^{m_1}y^{m_2} \dots z^{m_n}$ birhadlarni solishtiraylik. $k_1 = m_1, k_2 = m_2, \dots, k_i = m_i$, lekin $k_{i+1} > m_{i+1}$ bo'lsa, birinchi birhad ikkinchisidan katta, chunki ulardagi x va y lar daraja ko'rsatkichlari bir xil bo'lsa-da, z ning ko'rsatkichi birinchi birhadga katta.

Agar ko'p o'zgaruvchili ko'phadda har qaysi qo'shiluvchi o'zidan o'ngda turgan barcha qo'shiluvchilardan katta bo'lsa, qo'shiluvchilar *lug'aviy (leksikografik)* tartibda joylashtirilgan deyiladi. Masalan, $P(x, y, z) = 8x^5y^6z^2 - 5x^4y^8z + 16x^4y^5z^4$ ko'phadning qo'shiluvchilari lug'aviy tartibda joylashtirilgan.

Agar ko'phadning barcha hadlarida x, y, \dots, z o'zgaruvchilarning ko'rsatkichlari yig'indisi m ga teng bo'lsa, uni *m-darajali bir jinsli ko'phad* deyiladi. Masalan, $8x - 5y + z$ - birinchi darajali bir jinsli (bunda $m = 1$). $x^3 + y^3 + z^3 - 7xy^2 - 5xyz$ - uchinchi darajali ($m = 3$) bir jinsli ko'phad.

Agar $ax^{k_1} \dots z^{k_n}$ birhad $m = k_1 + \dots + k_n$ darajali bo'lsa, ixtiyoriy umumiy λ ko'paytuvchi uchun $a(\lambda x)$ ga ega bo'lamiz.

Agar ixtiyoriy λ soni uchun $f(\lambda x, \dots, \lambda z) = \lambda^m f(x, \dots, z)$ tenglik bajarilsa, $f(x, \dots, z)$ ko'phad (funksiya) m - darajali bir jinsli ko'phad (funksiya) bo'ladi. Masalan, $f(x, y) = y^3 + x^2 \sqrt{xy + \frac{x^3}{y}}$ funksiya 3- darajali bir jinsli funksiyadir, chunki

$$f(2x, 2y) = 8y^3 + 4x^2 \cdot \sqrt{4 \left(xy + \frac{x^3}{y} \right)} = 2^3 f(x, y).$$

Shu kabi, $f(x, y) = x^3 + 2x^2y - y^3 + x^2 \sqrt{xy + \frac{x^3}{y}}$ — uchinchi darajali ($m = 3$), $f(x, y, z) = \frac{y+z}{3x+y}$ nolinchida darajali ($m = 0$),

$f(x, y, z) = z \cdot \frac{y+z}{3x+y}$ birinchi darajali ($m = 1$) bir jinsli funksiyalardir. Agar $x^3y + xy^3$ ko'phadda x o'rniga y , y o'rniga x yozilsa (ya'ni x va y lar o'rin almashtirilsa), oldingi ko'phadning o'zi hosil bo'ladi.

Agar $P(x, y, \dots, z)$ ko'phad tarkibidagi harflarning har qanday o'rin almashtirilishida unga aynan teng ko'phad hosil bo'lsa, P ko'phad *simmetrik ko'phad* deyiladi. Simmetrik ko'phadda qo'shiluvchilar o'rin almashtirilganda yig'indi, ko'paytuvchilar o'rin almashtirilganda ko'paytma o'zgarмайdi.

Agar $(\lambda + x)(\lambda + y) \dots (\lambda + z)$ ifodadagi qavslar ochilsa, λ darajalarining koeffitsiyentlari sifatida x, y, \dots, z o'zgaruvchilarning simmetrik ko'phadlari turgan bo'ladi. Ular *asosiy simmetrik ko'phadlar* deyiladi. Masalan, o'zgaruvchilar soni $n = 2$ bo'lsa, $(\lambda + x)(\lambda + y) = \lambda^2 + (x + y)\lambda + xy$ bo'lib, asosiy simmetrik ko'phadlar $x + y$ va xy bo'ladi. Ularni $\sigma_1 = x + y$, $\sigma_2 = xy$ orqali ifodalaymiz. Shu kabi, $n = 3$ da $\sigma_1 = x + y + z$, $\sigma_2 = xy + xz + yz$, $\sigma_3 = xyz$ bo'ladi.

Bulardan tashqari, quyidagi ko'rinishdagi $\sigma_1 = x + y + \dots + z$ (n ta qo'shiluvchi), $\sigma_2 = x^2 + y^2 + \dots + z^2$, ..., $\sigma_k = x^k + y^k + \dots + z^k$ darajali yig'indilar ham simmetrik ko'phadlardir.

1-teorema. *Ixtiyoriy $s_k = x^k + y^k$ darajali yig'indi $\sigma_1 = x + y$ va $\sigma_2 = xy$ larning ko'phadi ko'rinishida tasvirlanishi mumkin.*

I s b o t. Haqiqatan, $k = 1$ da $s_1 = x + y = \sigma_1$, $k = 2$ da $s_2 = x^2 + y^2 = (x + y)^2 - 2xy = \sigma_1^2 - 2\sigma_2$. Teorema s_{n-1} va s_n (bunda $1 \leq n \leq k$, $k \leq 2$) uchun to'g'ri bo'lsin. Uning s_{n+1} uchun to'g'riligini isbotlaymiz:

$$\begin{aligned} s_{n+1} &= x^{n+1} + y^{n+1} = (x^n + y^n)(x + y) - x^n y - xy^n = \\ &= (x^n + y^n)(x + y) - (x^{n-1} + y^{n-1})xy = s_n \sigma_1 - s_{n-1} \sigma_2. \end{aligned}$$

Faraz bo'yicha s_n va s_{n-1} lar uchun teorema to'g'ri edi. Demak, teorema s_{n+1} uchun ham to'g'ri.

2- t e o r e m a. x, \dots, z o'zgaruvchilari har qanday simmetrik P ko'phad yagona ravishda shu o'zgaruvchilardan tuzilgan asosiy simmetrik ko'phadlardan iborat bo'ladi.

I s b o t. $n = 2$ bo'lgan holni qaraymiz. $P(x, y)$ simmetrik ko'phad $ax^m y^k$ qo'shiluvchiga ega bo'lsin. Agar $m = k$ bo'lsa, bu qo'shiluvchi $a(xy)^k$ ga, ya'ni $a\sigma_2^k$ ga teng, $k > m$ bo'lsa, $P(x, y)$ ning tarkibida $ax^m y^k$ bilan bir qatorda x va y larni o'rin almashtirishdan hosil bo'luvchi $ax^k y^m$ qo'shiluvchi ham bo'ladi: $ax^k y^m + ax^m y^k = a(xy)^m(x^{k-m} + y^{k-m}) = a\sigma_2^m s_{k-m}$. Lekin 1- teoremaga muvofiq ixtiyoriy s_{k-m} darajali yig'indi, demak, P simmetrik ko'phad ham har doim σ_1, σ_2 orqali ifodalanadi.

1- m i s o l. $P(x, y) = x^3 + y^3 + 2x^2 y + 2xy^2$ simmetrik ko'phadni σ_1 va σ_2 lar orqali ifodalaymiz.

Y e c h i s h. $P(x, y) = (x + y)(x^2 - xy + y^2) + 2xy(x + y) = (x + y)(x^2 - xy + y^2 + 2xy) = (x + y)((x + y)^2 - xy) = \sigma_1(\sigma_1^2 - \sigma_2)$.

$P(x) = a_n x^n + a_{n-1} x^{n-1} + \dots + a_1 x + a_0$ ($a_n \neq 0$) ko'rinishdagi butun ratsional ifoda bir o'zgaruvchili n - darajali ko'phad deyiladi. Har qanday son θ - darajali ko'phaddan iborat. θ soni esa darajaga ega bo'lmagan ko'phad. $a_n x^n$ qo'shiluvchi ko'phadning bosh hadi, a_0 esa uning ozod hadi deyiladi.

3- t e o r e m a. O'zgaruvchi x bo'yicha tuzilgan har qanday butun ratsional ifoda

$$a_n x^n + a_{n-1} x^{n-1} + \dots + a_1 x + a_0 \quad (1)$$

ko'rinishdagi ifodaga aynan tengdir, bunda a_n, \dots, a_0 – haqiqiy sonlar, $a_n \neq 0$.

I s b o t. Teorema sonlar va x ifoda uchun har doim o'rinli. U $A(x)$ va $B(x)$ ifodalar uchun o'rinli, deylik: $A(x) = a_m x^m + \dots + a_0$ ($m > n$), $B(x) = b_n x^n + \dots + b_0$. U holda $A(x) + B(x) = (a_m x^m + \dots + a_0) + (b_n x^n + \dots + b_0) = (a_m x^m + \dots + a_0) + (0 \cdot x^m + \dots + 0 \cdot x^{n+1} + b_n x^n + \dots + b_0) = (a_m + 0)x^m + \dots + (a_0 + b_0)$ yig'indi (1) ko'rinishda bo'ladi. Shu kabi,

$$A(x)B(x) = (a_m x^m + \dots + a_0)(b_n x^n + \dots + b_0) = \dots = \sum_{i=0}^{m+n} c_i x^i, \quad (2)$$

$c_i = a_i b_0 + a_{i-1} b_1 + \dots + a_1 b_{i-1} + a_0 b_i$ (agar $i > m$ bo'lsa, $a_i = 0$ bo'ladi).

Shunday qilib, teorema barcha sonlar va x ifoda uchun o'rinli, uning $A(x)$ va $B(x)$ uchun o'rinli bo'lganidan $A(x) + B(x)$ va $A(x) \cdot B(x)$ uchun o'rinli bo'lishi kelib chiqadi. Demak, teorema barcha ratsional ifodalar uchun o'rinli.

(2) tenglikka qaraganda, ikki ko'phad ko'paytmasining bosh hadi ko'payuvchilar bosh hadlarining ko'paytmasiga, ozod hadi ozod hadlarining ko'paytmasiga teng, ko'paytmaning darajasi ko'payuvchilar darajalarining yig'indisiga teng. Bir xil darajali ko'phadlarni qo'shganda kichik darajali ko'phad hosil bo'lishi mumkin, turli darajali ko'phadlarni qo'shganda esa darajasi katta darajali qo'shiluvchining darajasi bilan bir xil bo'lgan ko'phad hosil bo'ladi. Masalan, $(4x^2 - x + 3) + (-4x^2 - 2x + 1) = -3x + 4$, $(4x^2 - x + 3) + (-2x + 1) = 4x^2 - 3x + 4$.

Ikki ko'phadning aynan teng bo'lish shartini ifodalovchi teoremani isbotsiz keltiramiz.

3- t e o r e m a. Agar $P(x)$ ko'phadning hech bo'lmaganda bitta koeffitsiyenti noldan farqli bo'lsa, shunday $x_0 \in \mathbb{R}$ soni topiladiki, unda ko'phad nolga aylanmaydi, ya'ni $P(x) \neq 0$ bo'ladi.

1- x u l o s a. Agar x ning har qanday qiymatida $P(x)$ ko'phad nolga teng bo'lsa, u holda uning barcha koeffitsiyentlari nolga teng bo'ladi.

I s b o t. Barcha $x \in R$ uchun $P(x) = 0$ bo'lsin. Agar $P(x)$ ning biror koeffitsiyenti nolga teng bo'lmasa, 3- teorema muvofiq shunday $x = b$ soni topiladiki, unda $P(b) \neq 0$ bo'ladi. Bu esa $\forall x \in R$ uchun $P(x) = 0$ bo'lishlik shartiga zid. Demak, barcha koeffitsiyentlar nolga teng.

2- x u l o s a. Aynan teng $P(x)$ va $Q(x)$ ko'phadlarda x ning bir xil darajalari oldidagi koeffitsiyentlari teng bo'ladi.

I s b o t. $P(x) \equiv Q(x)$ bo'lgani uchun $P(x) - Q(x) \equiv 0$ bo'ladi. I xulosaga ko'ra, bu ayirmaning barcha koeffitsiyentlari nolga teng. Bundan, $P(x)$ va $Q(x)$ ko'phadlarning mos koeffitsiyentlari teng bo'lishi kelib chiqadi.

1- m i s o l. Agar $P(x) = (x^2 + 2)^3 - 6(x^2 - 2)^2 - 4x^3 - 36x^2 + 20$ va $Q(x) = (x^3 - 2)^2$ bo'lsa, $P(x) \equiv Q(x)$ bo'lishini isbot qilamiz.

I s b o t. $P(x) = (x^6 + 3 \cdot 2x^4 + 3 \cdot 4x + 8) - 6(x^4 - 4x^2 + 4) - 4x^3 - 36x^2 + 20 = x^6 - 4x^3 + 4$, $Q(x) = x^6 - 4x^3 + 4$. Demak, $P(x) \equiv Q(x)$.

Amalda (masalan, kalkulatorlarda hisoblashlar sonini kamaytirish maqsadida) butun ratsional ifodalarning quyidagi ko'rinishdagi yozuvidan foydalanish qulay:

$$(\dots((a_n x + a_{n-1})x + a_{n-2})x + \dots) + a_0. \quad (3)$$

2- m i s o l. $P(x) = 5x^4 + 4x^3 - 7x^2 - 2x + 4$ ifodaning $x = 3,89$ dagi son qiymatini hisoblash zarur bo'lsin. Shu yozuv bo'yicha jami 14 marta, $P(x) = (((5x + 4)x - 7)x - 2)x + 4$ ko'rinishi bo'yicha esa 9 marta amal bajariladi.

3- m i s o l. $P(x) = (3x - 1)^{99} \cdot (2x - 1)^{100} + x^2$ ko'phad koeffitsiyentlarining yig'indisini va ozod hadini toping.

Y e c h i s h. $P(x)$ ko'phad koeffitsiyentlarining yig'indisi $P(1) = (3 \cdot 1 - 1)^{99} \cdot (2 \cdot 1 - 1)^{100} + 1^2 = 2^{99} + 1$ ga, ozod hadi esa $P(0) = (3 \cdot 0 - 1)^{99} \cdot (2 \cdot 0 - 1)^{100} + 0^2 = -1$ ga teng.



Mashqlar

4.10. Ko'phadni ko'paytuvchilarga ajrating:

a) $7ax + 14ay$;

b) $3a^2x + 6a^4x^3$;

- d) $ax + bx + x$; i) $5(x - 3) - a(3 - x)$;
 e) $a^3 - 2a^2 - a$; j) $5x^{a+2} + 10x^2$;
 f) $x(a - c) + y(c - a)$; k) $a^{3x} - a^{2x}$;
 g) $a(x - y) - (y - x)$; l) $a^c x^{2c} + a^c x^c$;
 h) $2y(x - 3) - 5c(3 - x)$; m) $15x^{2c+3} + 25x^{c+1}$.

4.11. Isbotlang:

- a) $(a - b)(a + b) = a^2 - b^2$;
 b) $(a + b)^2 = a^2 + 2ab + b^2$;
 d) $(a - b)^2 = a^2 - 2ab + b^2$;
 e) $(a + b)(a^2 - ab + b^2) = a^3 + b^3$;
 f) $(a - b)(a^2 + ab + b^2) = a^3 - b^3$;
 g) $(a + b)^3 = a^3 + 3a^2b + 3ab^2 + b^3$;
 h) $(a - b)^3 = a^3 - 3a^2b + 3ab^2 - b^3$;
 i) $(a + b + c)^2 = a^2 + b^2 + c^2 + 2ab + 2ac + 2bc$.

4.12. Kasrning qiymatini toping:

- a) $\frac{35^2 - 18^2}{72^2 - 16^2}$; b) $\frac{39,5^2 - 3,5^2}{57,5^2 - 14,5^2}$;
 d) $\frac{856^2 - 44^2}{406}$; e) $\frac{71^2 - 23^2 + 94 \cdot 42}{62^2 - 32^2}$;
 f) $\frac{63^2 - 23^2}{71^2 - 15^2 - 86 \cdot 24}$; g) $\frac{(4^{k+1} + 6 \cdot 4^k)^3}{(8^{k+1} + 2 \cdot 8^k)^2}, k \in N$;
 h) $\frac{(8^{k+1} + 8^k)^2}{(4^k + 4^{k-1})^3}, k \in N$; i) $\frac{(13^2 - 11^2)(13^2 + 11^2)}{36^2 - 12^2}$.

4.13. Ko'paytuvchilarga ajrating:

- a) $x^2 - y^2 - x - y$;
 b) $x^2 - 2xy + y^2 - c^2$;
 d) $(x - 5)^2 - 16$;
 e) $2x^2 - 4x + 2$;
 f) $ax^2 - a - x^2 + x$;

g) $x^3 + y^3 + 2xy(x + y)$;

h) $x^3 - y^3 - 5x(x^2 + xy + y^2)$;

i) $a^4 + ax^2 - a^3x - x^4$;

j) $(x + y)(x^2 + y^2) - x^3 - y^3$;

k) $36a^2 - (a^2 + 9)^2$;

l) $8x^3 - 27y^{18}$;

m) $(x - y)(x^3 + y^3)(x^2 + xy + y^2) - (x^6 - y^6)$.

4.14. k ning istalgan natural qiymatida

a) $(k + 1)^2 - (k - 1)^2$ ning qiymati 4 ga;

b) $(2k + 3)^2 - (2k - 1)^2$ ning qiymati 8 ga;

d) $k^3 - k$ ning qiymati 6 ga;

e) $(3k + 1)^2 - (3k - 1)^2$ ning qiymati 12 ga bo'linishini isbotlang.

4.15. Agar $a + b + c = 0$ bo'lsa, $a^3 + b^3 + c^3 = 3abc$ bo'lishini isbotlang.

4.16. Sonlarni taqqoslang:

a) $45^2 - 31^2$ va $44^2 - 30^2$;

d) $297 \cdot 299$ va 298^2 ;

b) $26^3 - 24^3$ va $(26 - 24)^3$;

e) $(17 + 13)^3$ va $17^3 + 13^3$.

4.17. $ab = 0$ bo'lsa, $|a + b|$ ning qiymati nimaga teng bo'lishi mumkin? ($\sqrt{x^2} = |x|$ dan foydalaning.)

4.18. $|a|^2 + |b|^2 + |c|^2 = 0$ bo'lsa, $(a + b + c)^2$ ning qiymatini toping.

4.19. $(x + y + z)^2 - 2xy - 2xz$ ni soddalashtiring.

4.20. $(x - y - z)^2$ ni ko'phadga aylantiring.

4.21. $f(x) = x^3 - 3x^2 + 2x - 1$ ko'phad berilgan. Quyidagilarni hisoblang:

a) $f(2)$;

f) $f(1 - i)$;

j) $f(x - 1)$;

b) $f(i)$;

g) $f(i + 2)$;

k) $f(a)$;

d) $f(i + 1)$;

h) $f(-i)$;

l) $f(2^n)$;

e) $f(\sqrt{2})$;

i) $f(\sqrt{3} - 1)$;

m) $f\left(\frac{1}{\sqrt{3}}\right)$.

4.22. Ko'phad koeffitsiyentlarining yig'indisini toping:

a) $f(x) = (4x - 1)^{1999}(2x - 1)^{2000} + (8x - 1)^2(4x - 1)$;

b) $f(x) = (3x - 2)^{2000}(3x - 1)^{199} + (8x + 1)^2 + 2$;

d) $f(x) = (x - 2)^{200}(2 - x) + (4 - x)^{99}(x - 1)^{20} + 3$;

e) $f(x) = (x - 1)(x - 2)^{20} + (4 - 4x)^{18}(x + 3)^2 + 17$.

4.23. $f(x)$ ko'phad koeffitsiyentlarining yig'indisi m ga teng. a ni toping:

a) $f(x) = x^3 + ax^2 + 3x + 1$; $m = 5$;

b) $f(x) = 7x^3 + 2x^2 + ax + 2$; $m = 4$;

d) $f(x) = 12x^4 + 2x^3 + ax^2 + 1$; $m = 12$;

e) $f(x) = ax^2 + 4x^4 + 8x + 1$; $m = -4$.

4.24. Ko'phadning ozod hadini toping:

a) $f(x) = (3x^2 - 1)^{20}(4x + 1)^{15} - x^{20} + 15$;

b) $f(x) = (3x - 4)^{18}(13x - 1)^{16} + x^{17} - 15$;

d) $f(x) = (2x + 1)^{15}(3x^2 + 2)^4 + (x - 2)^2 + 17$;

e) $f(x) = (3x + 1)^2(3x + 4)^3(x + 1)^{200} + (x - 1)^{20} + 19$.

4.25. $f(x)$, $g(x)$ lar teng ko'phadlar bo'lsa, a , b larni toping:

a) $f(x) = ax^7 + 3x^6 + x^2 + 1$, $g(x) = 3x^6 + bx^2 + 1$;

b) $f(x) = ax^3 + bx^2 + 3x + 2$, $g(x) = x^3 + bx^2 + 3x + 2$;

d) $f(x) = ax^3 + 2x + 3$, $g(x) = 4x^3 + bx + 3$;

e) $f(x) = ax^8 + bx^3 + 9$, $g(x) = ax^{10} + 4x^3 + ax^2 + 9$.

4.26. $x + 5 = a(x - 2)(x - 3) + b(x - 1)(x - 3) + c(x - 1)(x - 2)$ tenglik ayniyat bo'lsa, a , b , c larni toping.

4.27. Ko'phadlar yig'indisini toping:

a) $f(x) = x^{88} + 3x^{77} + 4x^2 + 1$, $g(x) = 4x^{88} + 3x^{65} + 15$;

b) $f(x) = x^4 - 5x^3 + 4x^2 - 1$, $g(x) = -x^4 + 6x^3 + x + 2$;

d) $f(x) = x^6 + 5x^2 + 11x + 4$, $g(x) = 2x^6 + x^4 + 3x^3 + 5$;

e) $f(x) = x^7 + x^6 + 5x^4 + 12$, $g(x) = 7x^3 + 8x^2 - 11$.

4.28. Ko'phadlar yig'indisining darajasini toping:

a) $f(x) = (x-1)^7(x-2)^5 + 3x$, $g(x) = (2x-4)^{12} + 4x^2$;

b) $f(x) = (2x+5)^{15} + 3x^4 + 4$, $g(x) = (2x+3)^{16} - 4x^3 + x + 1$;

d) $f(x) = (3x+5)^{15} + 31x^5 + 2$, $g(x) = -(3x+11)^{15} + 33x^6 + 4$;

e) $f(x) = x^7 + x^6 + 3x^2 + x + 3$, $g(x) = -x^7 + 2x^6 + 4x^5 + 2$.

4.29. 4.27- misoldagi ko'phadlar uchun $f(x) - g(x)$ ni toping.

4.30. Ko'phadlarni ko'paytiring:

a) $f(x) = 5x^4 + 4x^2 + x + 2$, $g(x) = 4x$;

b) $f(x) = 4x^4 + 3x^3 + 2$, $g(x) = 4x^3 + 7x + 1$;

d) $f(x) = 11x^4 + 3x^2 + 3x + 5$, $g(x) = 5x^6 + 7x^2 + 4x + 2$;

e) $f(x) = 13x^3 + 4x^2 + x + 2$, $g(x) = 2x^2 + 5x + 6$.

4.31. Ayniyatlarni isbotlang:

1) $(x^2 + y^2 + z^2)(u^2 + v^2 + w^2) =$
 $= (xu + yv + zw)^2 + (zv - yw)^2 + (xw - zu)^2 + (xv + yu)^2$;

2) $(y - z)^5 + (z - x)^5 + (x - y)^5 =$
 $= 5(x - y)(y - z)(z - x)(x^2 + y^2 + z^2 - xy - yz - xz)$.

4.32. a) x , y , z ning s_2 , s_3 , s_4 darajali yig'indilarini σ_1 va σ_2 asosiy simmetrik ko'phadlar orqali ifodalang;

b) $x^4 + y^4 = \sigma_1^4 - 4\sigma_1^2\sigma_2 + 2\sigma_2^2$ tenglikni isbot qiling.

4.33. a) $x^2 - 4x + 3 = 0$ kvadrat tenglamani yechmay,

1) shunday yangi kvadrat tenglama tuzingki, uning ildizlari berilgan tenglama x_1 , x_2 ildizlari kvadratlaridan iborat bo'lsin;

2) yangi kvadrat tenglama ildizlari $\alpha_1 = x_1 + 2x_2$ va $\alpha_2 = x_2 + 2x_1$ bo'lsin;

b) $x^2 + x - 2 = 0$ tenglamani yechmasdan, uning ildizlarining uchinchi darajali yig'indisini toping.

4.34. 1) $x^3 + 4x^2y + 4xy^2 + y^3$; 2) $x^4 - 5x^4y + 6x^3y^2 + 6x^2y^3 - 5xy^4 + y^5$ simmetrik ko'phadlarni α_1 va α_2 lar orqali ifodalang.

4.35. σ_1 va σ_2 lardan iborat ko'paytuvchilarga ajrating:

a) $x^4 - 12x^3y + 15x^2y^2 - 12xy^3 + y^4$;

$$b) 16x^4 + 13x^3y + 8x^2y^2 + 13xy^3 + 16y^4;$$

d) butun koeffitsiyentli $P(x,y) = Ax^2 + 2Bxy + Cy^2 + 2Dx + 2Ex + F$ ko'phad ratsional koeffitsiyentli $ax + by + c$ uchun hadning aniq kvadrati bo'lishi uchun A, B, C, D, E, F koeffitsiyentlarga nisbatan qanday shartlar qo'yilishi kerak?

3. Qisqa ko'paytirish formulalarining umumlashmalari. Agar ko'phadni ko'phadga ko'paytirish qoidalaridan foydalanib, zarur soddalashtirishlarni bajarsak, quyidagi formulalar hosil bo'ladi:

$$(x \pm a)^2 = x^2 \pm 2ax + a^2,$$

$$(x \pm a)^3 = x^3 \pm 3x^2a + 3xa^2 \pm a^3,$$

$$(x + a)(x - a) = x^2 - a^2,$$

$$(x + a)(x^2 - ax + a^2) = x^3 + a^3,$$

$$(x - a)(x^2 + ax + a^2) = x^3 - a^3,$$

$$(x + y + z)^2 = x^2 + y^2 + z^2 + 2xy + 2xz + 2yz$$

va hokazo.

Endi $x + a$ ikkihadni m natural ko'rsatkichli darajaga ko'tarish qonuniyati bilan tanishamiz. Shu maqsadda $(x + a)$, $(x + a)^2$, $(x + a)^3$, $(x + a)^4$ va hokazo darajalarga ko'tarishlarni bajarib, hosil bo'lgan yoyilmaning koeffitsiyentlarini kuzataylik:

$$(x + a)^1 = 1x + 1a,$$

$$(x + a)^2 = 1x^2 + 2ax + 1a^2,$$

$$(x + a)^3 = 1x^3 + 3x^2a + 3xa^2 + 1a^3.$$

Yoyilmalardan bosh koeffitsiyentlar 1 ga tengligini ko'ramiz. Oxirgi ko'phadni $x + a$ ga ko'paytirib,

$$(x + a)^4 = 1x^4 + 4x^3a + 6x^2a^2 + 4a^3x + 1a^4$$

ni hosil qilamiz. Shu kabi,

$$(x + a)^5 = 1x^5 + 5x^4a + 10x^3a^2 + 10x^2a^3 + 5xa^4 + 1a^5$$

va hokazolarni hosil qilamiz.

$(x + a)^n$ uchun quyidagiga ega bo'lamiz:

1) yoyilmadagi barcha hadlarning soni $x + a$ ikkihad ko'tarilayotgan daraja ko'rsatkichidan bitta ortiq, ya'ni hadlar soni $n + 1$ ga teng;

2) x o'zgaruvchining ko'rsatkichi n dan 0 gacha 1 taga ketma-ket kamayib, a o'zgaruvchining darajasi esa 0 dan n gacha ketma-ket o'sib boradi. Har bir hadda x va a ning darajalari yig'indisi n ga teng;

3) yoyilma boshidan va oxiridan teng uzoqlikdagi hadlarning koeffitsiyentlari o'zaro teng, bunda birinchi va oxirgi hadlarning koeffitsiyentlari 1 ga teng;

4) $(x + a)^0, (x + a)^1, (x + a)^2, (x + a)^3, (x + a)^4, (x + a)^5$ va $(x + a)^6$ yoyilmalari koeffitsiyentlarini uchburchaksimon ko'rinishda joylashtiraylik:

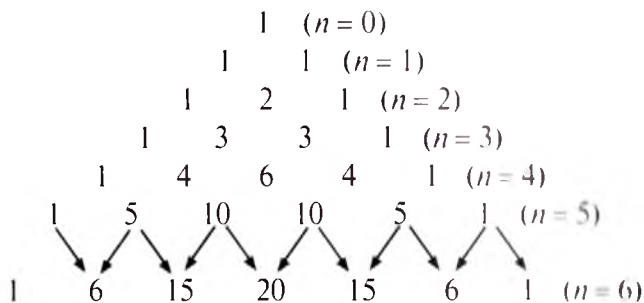

Har bir satrning koeffitsiyenti undan oldingi satr qo'shni koeffitsiyentlari yig'indisiga teng (strelka bilan ko'rsatilgan).

Koeffitsiyentlarning bu uchburchak jadvali *Paskal uchburchagi* nomi bilan ataladi. Undan foydalanib, $(x + a)^6 = x^6 + 6x^5a + 15x^4a^2 + 20x^3a^3 + 15x^2a^4 + 6xa^5 + a^6$ ekanini ko'ramiz.

n ning katta qiymatlarida Paskal uchburchagidan foydalanish ancha noqulay. Masalan, $n = 20$ da hisoblash uchun dastlabki 19 qatorni yozish kerak bo'lardi.

Umumiy holda ushbu Nyuton binomi formulasidan foydalaniladi:

$$\begin{aligned}
 (a + b)^n &= a^n + na^{n-1}b + \frac{n(n-1)}{2}a^{n-2}b^2 + \dots + \\
 &+ \frac{n(n-1)(n-2)\dots(n-(k-1))}{1 \cdot 2 \cdot 3 \dots k} a^{n-k} \cdot b^k + \dots + n \cdot ab^{n-1} + b^n. \quad (1)
 \end{aligned}$$

Masalan:

$$\begin{aligned}(x+y)^6 &= x^6 + 6x^5y + \frac{6 \cdot 5}{1 \cdot 2}x^4y^2 + \frac{6 \cdot 5 \cdot 4}{1 \cdot 2 \cdot 3}x^3y^3 + \\ &+ \frac{6 \cdot 5 \cdot 4 \cdot 3}{1 \cdot 2 \cdot 3 \cdot 4}x^2y^4 + \frac{6 \cdot 5 \cdot 4 \cdot 3 \cdot 2}{1 \cdot 2 \cdot 3 \cdot 4 \cdot 5}xy^5 + \frac{6 \cdot 5 \cdot 4 \cdot 3 \cdot 2 \cdot 1}{1 \cdot 2 \cdot 3 \cdot 4 \cdot 5 \cdot 6}y^6 = \\ &= x^6 + 6x^5y + 15x^4y^2 + 20x^3y^3 + 15x^2y^4 + 6xy^5 + y^6.\end{aligned}$$

(1) ni matematik induksiya metodidan foydalanib isbotlaymiz.

$n = 1$ da $a + b = a + b$, ya'ni (1) tenglik to'g'ri.

$n = m$ da (1) tenglik to'g'ri, ya'ni $(a + b)^m = a^m + ma^{m-1}b + \dots + b^m$ tenglik o'rinli deb faraz qilamiz.

U holda $n = m + 1$ uchun

$$\begin{aligned}(a+b)^{m+1} &= (a+b)^m \cdot (a+b) = a^m + ma^{m-1}b + \frac{m(m-1)}{1 \cdot 2}a^{m-2}b^2 + \\ &+ \dots + \frac{m(m-1)(m-2) \dots (m-(k-1))}{1 \cdot 2 \cdot 3 \dots k}a^{m-k}b^k + \dots + \\ &+ mab^{m-1} + b^m)(a+b) = a^{m+1} + (m+1)a^m b + \frac{(m+1)m}{1 \cdot 2}a^{m-1}b^2 + \dots + \\ &+ \frac{(m+1)m(m-1) \dots (m-k)}{1 \cdot 2 \cdot 3 \dots (k+1)}a^m b^{k+1} + \dots + (m+1)ab^m + b^{m+1}\end{aligned}$$

bo'ladi. Demak, (1) formula o'rinli.



M a s h q l a r

4.36. Ko'phad shaklida yozing:

- | | | |
|--------------------|------------------|------------------|
| a) $(x+y+z)^2$; | e) $(x+y-z)^2$; | h) $(a+b)^7$; |
| b) $(x+y+z)^3$; | f) $(x+y-z)^3$; | i) $(2x+3y)^8$; |
| d) $(a+b+c+d)^2$; | g) x^6+y^6 ; | j) $(5x-4y)^6$. |

4.37. Ko'paytuvchilarga ajrating:

- | | |
|----------------------------------|-------------------------------|
| a) $a^4 - 1$; | b) $a^{12} - 2a^6 + 1$; |
| d) $a^2 - 2a^3b - 2ab^3 + b^2$; | e) $a^3 - 7a^3 - 7a + 15$; |
| f) $a^3 - 5a^2 - a + 5$; | g) $a^4 - 10a^2 + 169$; |
| h) $a^{10} + a^5 + 1$; | i) $(x+3)^4 + (x+5)^4 - 16$; |
| j) $a^3 + b^3 + c^3 - 3abc$. | |

4.38. Ayniyatlarni isbot qiling:

- a) $(x^2 - 1)(x^2 + 1)(x^4 + 1) = x^8 - 1$;
- b) $(x^2 + x + 1)(x^2 - x + 1) = x^4 + x^2 + 1$;
- d) $(x^2 - 3x + 1)^2 - 1 = (x - 3)(x - 2)(x - 1)x$;
- e) $x^5 + 1 = (x + 1)[x(x - 1)(x^2 + 1) + 1]$.

4.39. Ifodalarni soddalashtiring:

- 1) $(a^2 + a + 1)(a^2 - a + 1)(a^4 - a^2 + 1)$;
- 2) $(x + y + z)^2 - (x + y - z)^2 - (y + z - x)^2 + (z + x - y)^2$.

4.40. Ayniyatlarni isbot qiling:

- a) $(x^2 - y^2)(a^2 - b^2) = (ax + by)^2 - (ay + bx)^2$;
- b) $x^4 - 8x + 63 = (x^2 + 4x + 9)(x^2 - 4x + 7)$;
- d) $a^3 + b^3 + c^3 - 3abc = (a + b + c)(a^2 + b^2 + c^2 - ab - bc - ca)$;
- e) $x^4 + 2x^3 + 4x^2 + 3x - 10 = (x - 1)(x + 2)(x^2 + x + 5)$;
- f) $x^6 + 1 = (x^2 + 1)(x^4 - x^2 + 1)$;
- g) $x^6 - 2x^5 + 4x^4 + 2x^3 - 5x^2 = x^2(x - 1)(x + 1)(x^2 - 2x + 5)$.

4. Ko'phadlarni bo'lish. Bir o'zgaruvchili $A(x)$ va $B(x)$ ko'phadlar uchun

$$A(x) = B(x) \cdot Q(x) \quad (1)$$

tenglik o'rinli bo'ladigan $Q(x)$ ko'phad mavjud bo'lsa, $A(x)$ ko'phad $B(x)$ ko'phadga bo'linadi (yoki qoldiqsiz bo'linadi) deyiladi. Bunda $A(x)$ ko'phad bo'linuvchi, $B(x)$ ko'phad bo'luvchi, $Q(x)$ ko'phad esa bo'linma deyiladi.

$x^3 - 1 = (x^2 + x + 1)(x - 1)$ ayniyatdan, $A(x) = x^3 - 1$ ko'phadning $B(x) = x^2 + x + 1$ ko'phadga (qoldiqsiz) bo'linishini va bo'linma $Q(x) = x - 1$ ko'phadga tengligini ko'ramiz.

Butun sonni butun songa (butun) bo'lish amali kabi, ko'phadni ko'phadga qoldiqsiz bo'lish amali hamma vaqt ham bajarilavermaydi. Shu sababli ko'phadni ko'phadga qoldiqsiz bo'lishga nisbatan yanada umumiyroq bo'lgan amal — ko'phadni ko'phadga qoldikli bo'lish amali kiritiladi.

$A(x)$ ko'phadni $B(x)$ ko'phadga qoldikli bo'lish deb, uni quyidagicha ko'rinishda tasvirlashga aytiladi:

$$A(x) = B(x) \cdot Q(x) + R(x). \quad (2)$$

(2) tenglikdagi $Q(x)$ va $R(x)$ lar bir o'zgaruvchili ko'phadlar bo'lib, $R(x)$ ko'phadning darajasi $B(x)$ ko'phadning darajasidan kichik yoki $R(x) = 0$.

(2) tenglikdagi $A(x)$ ko'phad *bo'linuvchi*, $B(x)$ ko'phad *bo'luvchi*, $Q(x)$ ko'phad *bo'linma* (yoki to'liqsiz bo'linma), $R(x)$ ko'phad esa *qoldiq* deyiladi.

Agar (2) tenglikda $R(x) = 0$ bo'lsa, (1) tenglik hosil bo'ladi, ya'ni $A(x)$ ko'phad $B(x)$ ko'phadga qoldiqsiz bo'linadi. Shu sababli qoldiqsiz bo'lishni qoldikli bo'lishning xususiy holi sifatida qaraymiz.

Oliy matematika kursida, har qanday $A(x)$ ko'phadning har qanday $B(x)$ ko'phadga (bu yerda $B(x) \neq 0$) qoldikli bo'linishi haqidagi quyidagi teorema isbotlanadi.

Teorema. *$A(x)$ va $B(x)$ ko'phadlar haqiqiy koeffitsiyentli va $B(x) \neq 0$ bo'lsin. U holda shunday $Q(x)$ va $R(x)$ ko'phadlar topiladiki, ular uchun $A(x) = B(x) \cdot Q(x) + R(x)$ tenglik o'rinli bo'ladi va bunda $R(x)$ ning darajasi $B(x)$ nikidan kichik yoki $R(x) = 0$ bo'ladi hamda $Q(x)$, $R(x)$ ko'phadlar bir qiymatli aniqlanadi.*

Bu teorema ko'phadni ko'phadga bo'lishning amaliy usulini bermaydi. Ko'phadni ko'phadga bo'lishning amaliy usullari – «*aniqmas koeffitsiyentlar usuli*» va «*burchakli bo'lish*» usulini misollarda qaraymiz.

1- misol. $A(x) = x^3 + x + 1$ ko'phadni $B(x) = x^2 + x + 1$ ko'phadga aniqmas koeffitsiyentlar usuli bilan bo'lamiz.

Yechish. $A(x)$ ko'phad 3- darajali, $B(x)$ esa 2- darajali ko'phad bo'lgani uchun $Q(x)$ ko'phad 1- darajali ko'phad bo'lishi kerak. $A(x)$ ko'phadni $B(x)$ ko'phadga bo'lishdagi qoldiqning darajasi ko'pi bilan 1 ga teng bo'ladi. Shu sababli $Q(x)$ ni $Q(x) = ax + b$ ko'rinishda, $R(x)$ ni esa $R(x) = px + q$ ko'rinishda izlaymiz. Bu yerdagi a, b, p, q lar topilishi kerak bo'lgan aniqmas koeffitsiyentlardir.

$A(x) = B(x) \cdot Q(x) + R(x)$ tenglikni $x^3 + x + 1 = (x^2 + x + 1) \cdot (ax + b) + (px + q)$ ko'rinishda yozib, uning o'ng tomonidagi amallarni bajaramiz. Ixchamlashtirishlardan so'ng,

$x^3 + x + 1 = ax^3 + (a+b)x^2 + (a+b+p)x + (b+q)$ tenglikni hosil qilamiz. Ko'phadlarning tenglik shartiga ko'ra,

$$\begin{cases} a = 1, \\ a + b = 0, \\ a + b + p = 1, \\ b + q = 1 \end{cases} \text{ sistemaga ega bo'lamiz. Bundan } a = 1,$$

$b = -1, p = 1, q = 2$ ekanligi aniqlanadi.

Demak, $Q(x) = x - 1, R(x) = x + 2$.

2- misol. Ushbu

$$A(x) = \frac{3x^4 - 10ax^3 + 22a^2x^2 - 24a^3x - 10a^4}{x^2 + 2ax - 3a^2}$$

ifodadan butun qism ajratamiz. Buning uchun suratdagi ko'phadni maxrajdagi ko'phadga bo'lish lozim. Bo'lishni «burchakli bo'lish» usulida bajaramiz:

$$\begin{array}{r} 3x^4 - 10ax^3 + 22a^2x^2 - 24a^3x + 10a^4 \left| \begin{array}{l} x^2 - 2ax + 3a^2 \\ 3x^2 - 4ax + 5a^2 \end{array} \right. \\ \hline 3x^4 - 6ax^3 + 9a^2x^2 \\ \hline -4ax^3 + 13a^2x^2 - 24a^3x \\ \hline -4ax^3 + 8a^2x^2 - 12a^3x \\ \hline 5a^2x^2 - 12a^3x + 10a^4 \\ \hline 5a^2x^2 - 10a^3x + 15a^4 \\ \hline -2a^3x - 5a^4 \end{array}$$

Demak, $A(x) = 3x^2 - 4ax + 5a^2 + \frac{-2a^3x - 5a^4}{x^2 - 2ax + 3a^2}$.

n - darajali $A(x)$ va m - ($m \leq n$) darajali $B(x)$ ikkita ko'phad berilgan bo'lib, ularning eng katta umumiy bo'luvchisini topish talab qilinsin. Uni topishda Yevklid algoritmidan foydalanamiz: oldin $A(x)$ ni $B(x)$ ga bo'lamiz, so'ng $B(x)$ ni birinchi $r_1(x)$ qoldiqqa, undan so'ng $r_1(x)$ ni ikkinchi $r_2(x)$ qoldiqqa bo'lamiz va hokazo. Bo'linmalarni q_k orqali belgilaylik, bunda $k = 1, 2, 3, \dots$. Quyidagiga ega bo'lamiz:

$$A(x) = B(x) \cdot q_1(x) + r_1(x),$$

$$B(x) = r_1(x) \cdot q_2(x) + r_2(x),$$

$$r_1(x) = r_2(x) \cdot q_3(x) + r_3(x),$$

.....

$$r_{n-2}(x) = r_{n-1}(x) \cdot q_n(x) + r_n(x),$$

$$r_{n-1}(x) = r_n(x) \cdot q_{n+1}(x).$$

Agar $A(x)$ va $B(x)$ lar umumiy bo'luvchiga ega bo'lmasa (ya'ni eng katta umumiy bo'luvchi doimiy son bo'lsa), ular *o'zaro tub ko'phadlar* deyiladi.

Tenglamalarning karrali ildizlarini topish kabi masalalarni hal qilishda Yevklid algoritmidan foydalanadilar. Ketma-ket bo'lishlardan qoladigan qoldiqlarning darajalari (ular natural sonlar) kamayib, bir necha qadamdan so'ng 0 ga teng bo'ladi ($r_{n+1}(x) = 0$).

Undan oldingi noldan farqli $r_n(x) \neq 0$ qoldiq $A(x)$ va $B(x)$ ning eng katta umumiy bo'luvchisi bo'ladi.

3- misol. $A(x) = x^3 - 3x^2 + 3x - 1$ va $B(x) = x^2 - x$ ko'phadlarning eng katta umumiy bo'luvchisini topamiz.

$$\begin{array}{r|l} \text{Yechish. 1)} & x^3 - 3x^2 + 3x - 1 \quad | \quad x^2 - x \\ & \underline{x^3 - x^2} & | \quad x - 2 \\ & -2x^2 + 3x & \\ & \underline{-2x^2 + 2x} & \\ & r_1 = x - 1 & \end{array}$$

$$\begin{array}{r|l} 2) & x^2 - x \quad | \quad x - 1 \\ & \underline{x^2 - x} & \\ & r_2 = 0 & \end{array} \quad \begin{array}{l} \text{Eng katta umumiy bo'luvchi:} \\ x - 1. \end{array}$$

4- misol. $A(x) = x^3 - 3x^2 + 3x - 1$ va $B(x) = x^2 - x - 1$ larning eng katta umumiy bo'luvchisini topamiz.

Yechish. Ketma-ket bo'lishlar natijasida quyidagi oraliq natijalarni topamiz: $r_1(x) = 2x - 3$, $r_2 = -0,25 \neq 0$. Demak, $A(x)$ va $B(x)$ ko'phadlar umumiy bo'luvchiga ega emas, ya'ni ular *o'zaro tubdir*.

Mashqlar

4.41. $P(x)$ ni $D(x)$ ga qoldiqli bo'lishni bajaring:

a) $P(x) = x^3 + 5x^2 + 5x + 3$, $D(x) = x^2 + 4x + 1$;

b) $P(x) = x^3 + 5x^2 + 5x + 3$, $D(x) = x + 1$;

d) $P(x) = x^4 + 5x^3 + 9x^2 + 11x + 6$, $D(x) = x^2 + 3x + 1$;

e) $P(x) = x^4 + 5x^3 + 9x^2 + 11x + 6$, $D(x) = x^2 + 2x + 1$;

f) $P(x) = 3x^5 + 2x^4 - 10x^3 + 5x^2 + x + 10$, $D(x) = x^3 - x^2 + x - 1$;

g) $P(x) = 3x^5 + 2x^4 - 10x^3 + 5x^2 + x + 10$, $D(x) = x^2 + 3x - 4$;

h) $P(x) = 4x^6 + 3x^5 - 15x^2 + 4x + 5$, $D(x) = x^3 + 4x^2 - 1$;

i) $P(x) = 4x^6 + 3x^5 - 15x^2 + 4x + 5$, $D(x) = x^4 - 4x + 2$;

j) $P(x) = 3x^4 + 3x^2 + 5x + 4$, $D(x) = x^2 + 3x + 2$;

k) $P(x) = x^5 + 3x^4 + 9x^3 + 12x^2 + 20x$, $D(x) = x^3 + 4x$;

l) $P(x) = x^5 + 3x^4 + 9x^3 + 12x^2 + 20x$, $D(x) = x^2 + 3x + 5$;

m) $P(x) = 4x^4 + 5x^2 + 6x + 11$, $D(x) = x^2 + 5x - 4$.

4.42. Yevklid algoritmi yordamida ko'phadlarning eng katta umumiy bo'luvchisini toping:

a) $x^4 + x^3 + 3x^2 - 4x - 1$; $x^3 + x^2 - x - 1$;

b) $x^5 + x^4 - x^3 - 2x - 1$; $3x^4 + 2x^3 + x^2 + 2x - 2$;

d) $x^6 - 7x^4 - 8x^3 - 7x + 7$; $3x^5 - 7x^3 + 3x^2 - 7$;

e) $x^5 - 2x^4 + x^3 - 7x^2 - 12x + 10$; $3x^4 - 6x^3 + 5x^2 + 2x - 2$;

f) $x^6 + 2x^4 - 4x^3 - 3x^2 + 8x - 5$; $x^5 + x^2 - x + 1$;

g) $x^5 + 3x^4 - 12x^3 - 52x^2 - 52x - 12$; $x^4 + 3x^3 - 6x^2 - 22x - 12$;

h) $x^5 + x^4 - x^3 - 3x^2 - 3x - 1$; $x^4 - 2x^3 - x^2 - 2x + 1$;

i) $x^4 - 4x^3 + 1$; $x^3 - 3x^2 + 1$.

4.43. a va b ning qanday qiymatlarida $x^4 - 4x^3 - x^2 + ax - b$ ko'phad $x^2 - 5x + 4$ uchhadga qoldiqsiz bo'linadi?



1- §. Ratsional ifodalar

1. Butun ko'rsatkichli daraja. Har qanday a haqiqiy sonning α butun ko'rsatkichli darajasi yoki α - darajasi deb, a^α songa aytilishini bilamiz, bunda a – daraja asosi, α – daraja ko'rsatkichi.

$$a^\alpha = \begin{cases} a, & \text{agar } \alpha = 1 \text{ bo'lsa,} \\ \underbrace{a \cdot a \cdot \dots \cdot a}_{n \text{ marta}}, & \text{agar } \alpha = n, n \in N, n \geq 2 \text{ bo'lsa.} \end{cases}$$

Har qanday $a \neq 0$ haqiqiy sonning nolinch darajasi 1 ga teng, $a^0 = 1$. Nolning nolinch darajasi, ya'ni 0^0 ma'noga ega emas.

Ixtiyoriy $a \neq 0$ haqiqiy sonning butun manfiy ko'rsatkichli darajasi $\frac{1}{a^n}$ sonidan iborat, $a^{-n} = \frac{1}{a^n}$. 0^{-n} ifoda ma'noga ega emas.

Butun ko'rsatkichli darajaning xossalari (a, b – noldan farqli haqiqiy sonlar, α, β – butun sonlar):

$$1) \quad (ab)^\alpha = a^\alpha b^\alpha. \quad (1)$$

Haqiqatan, $\alpha = n \in N$ bo'lsa, haqiqiy sonlarni ko'paytirishning

$$\text{asosiy qonunlariga muvofiq: } (ab)^\alpha = (ab)^n = \underbrace{(ab)(ab)\dots(ab)}_{n \text{ ta}} =$$

$$= \underbrace{a \cdot a \cdot \dots \cdot a}_{n \text{ ta}} \cdot \underbrace{b \cdot b \cdot \dots \cdot b}_{n \text{ ta}} = a^n \cdot b^n = a^\alpha \cdot b^\alpha; \text{ agar } \alpha = 0 \text{ bo'lsa,}$$

$$(ab)^\alpha = (ab)^0 = 1 = 1 \cdot 1 = a^0 b^0 = a^\alpha b^\alpha; \text{ agar } \alpha = -n, n \in N \text{ bo'lsa,}$$

$$(ab)^\alpha = (ab)^{-n} = \frac{1}{(ab)^n} = \frac{1}{a^n b^n}. \text{ Xususan,}$$

$$\left(\frac{a}{b}\right)^\alpha = \frac{a^\alpha}{b^\alpha}, \quad (2)$$

$$2) \quad a^\alpha a^\beta = a^{\alpha+\beta}. \quad (3)$$

Haqiqatan, agar $\alpha = n$, $\beta = m$, $n \in \mathbb{N}$, $m \in \mathbb{N}$ bo'lsa, u holda:

$$\begin{aligned} a^\alpha \cdot a^\beta &= a^n \cdot a^m = \underbrace{a \cdot a \cdot \dots \cdot a}_{n \text{ ta}} \cdot \underbrace{a \cdot a \cdot \dots \cdot a}_{m \text{ ta}} = \\ &= \underbrace{a \cdot a \cdot \dots \cdot a}_{m+n \text{ ta}} = a^{m+n} = a^{(\alpha+\beta)}. \end{aligned}$$

$\alpha = n$, $\beta = -m$ va $\alpha = -n$, $\beta = m$ bo'lgan hollar ham shu kabi isbotlanadi. $\alpha = -n$, $\beta = -m$ holning isbotini quyidagicha bajarish mumkin:

$$\begin{aligned} a^\alpha a^\beta &= a^{-n} a^{-m} = \frac{1}{a^n} \cdot \frac{1}{a^m} = \frac{1}{a^n a^m} = \frac{1}{a^{n+m}} = a^{-(n+m)} = \\ &= a^{-n-m} = a^{(-n)+(-m)} = a^{\alpha+\beta}. \end{aligned}$$

$$3) \quad \frac{a^\alpha}{a^\beta} = a^{\alpha-\beta}. \quad (4)$$

$$4) \quad (a^\alpha)^\beta = a^{\alpha\beta}. \quad (5)$$

Xususan, $\alpha = n$, $\beta = m$, $n, m \in \mathbb{N}$ bo'lganda: $(a^\alpha)^\beta = (a^n)^m = \underbrace{a^n \cdot a^n \cdot \dots \cdot a^n}_{m \text{ ta}} = \underbrace{a a \dots a}_{n m \text{ ta}} = a^{nm} = a^{\alpha\beta}$.

Misol. $A = \frac{116^8 \cdot 87^4}{58^9 \cdot 174^3}$ ni hisoblang.

$$\text{Yechish. } A = \frac{(2 \cdot 58)^8 \cdot 87^4}{58^9 \cdot (2 \cdot 87)^3} = \frac{2^8 \cdot 87}{58 \cdot 2^3} = \frac{2^5 \cdot 3 \cdot 29}{2 \cdot 29} = 48.$$



Mashqlar

5.1. Ifodani soddalashtiring:

$$a) (0,25x^{-1}y^{-3})^2 \cdot \left(\frac{x^{-3}}{4y^2}\right)^3; \quad b) \left(\frac{a^3b^4}{9}\right) \cdot \left(\frac{3}{a^2b^3}\right)^3;$$

$$d) \left(\frac{c^{-1}}{10a^5b^2} \right)^{-2} \cdot (5a^3bc^2)^{-2}; \quad e) \left(\frac{x^2y^{-3}}{6z} \right)^{-3} \cdot \left(\frac{x^2y^{-2}}{9z} \right)^2.$$

5.2. O'zgaruvchilarning istagan qiymatida ifoda ayni bir qiymat qabul qilishini isbotlang ($m, n \in Z$):

$$a) \frac{2^m \cdot 3^{n-1} - 2^{m-1} \cdot 3^n}{2^m \cdot 3^n}; \quad d) \frac{5^m \cdot 4^n}{5^{m-2} \cdot 2^{2n} + 5^m \cdot 2^{2n-1}};$$

$$b) \frac{5^{n+1} \cdot 2^{n-2} + 5^{n-2} \cdot 2^{n-1}}{10^{n-2}}; \quad e) \frac{21^n}{3^{n-1} \cdot 7^{n+1} \cdot 3^n \cdot 7^n}.$$

2. Ratsional ifodalarni ayniy shakl almashtirish. Biror $X(x_1, \dots, x_n)$ algebraik ifodani *aynan almashtirish* deb, uni, umuman olganda, X ga o'xshamaydigan shunday $Y(x_1, \dots, x_n)$ algebraik ifodaga almashtirish tushuniladiki, barcha x_1, \dots, x_n qiymatlarda

X va Y qiymatlari teng bo'lsin. Masalan, $A(x) = \frac{(x^2+1)(x-1)}{x^2-1}$,

$B(x) = \frac{x^2+1}{x+1}$, $C(x) = \frac{(x^2+1)(x-1)(x+3)}{(x^2-1)(x+3)}$ lardan $A(x)$ ifoda barcha

$x \neq -1$, $x \neq 1$ qiymatlarda, $B(x)$ ifoda $x \neq -1$ qiymatlarda, $C(x)$ esa $x \neq -1$, $x \neq 1$, $x \neq -3$ qiymatlarda aniqlangan. Ularning umumiy mavjudlik sohasi $x \neq \pm 1$, $x \neq -3$ qiymatlardan iborat, unda ular bir xil qiymatlar qabul qilishadi, ya'ni *aynan tengdir*. Umumiy mavjudlik sohasida bir ratsional ifodani unga aynan teng ifoda bilan almashtirish shu ifodani *ayniy almashtirish* deyiladi. Ayniy almashtirishlardan tenglamalarni yechish, teoremlar va ayniyatlarni isbotlash kabi masalalarni yechishda foydalaniladi. Ayniy almashtirishlar kasrlarni qisqartirish, qavslarni ochish, umumiy ko'paytuvchini qavsdan tashqariga chiqarish, o'xshash hadlarni ixchamlash va shu kabilardan iborat bo'ladi. Ayniy almashtirishlarda arifmetik amallarning xossalardan foydalaniladi. Quyidagi ayniyatlar o'rinli:

$$1) (AB)^n = A^n B^n;$$

$$2) A^m A^n = A^{m+n};$$

$$3) (A^m)^n = A^{mn};$$

$$4) \frac{A}{B} + \frac{C}{D} = \frac{AD+BC}{BD}, \quad B \neq 0, \quad D \neq 0;$$

$$5) \frac{A}{B} \cdot \frac{C}{D} = \frac{AC}{BD}, \quad B \neq 0, \quad D \neq 0;$$

$$6) \frac{A}{B} : \frac{C}{D} = \frac{AD}{BC}, \quad B \neq 0, \quad C \neq 0, \quad D \neq 0;$$

$$7) \frac{AC}{BD} = \frac{A}{B}, \quad B \neq 0, \quad C \neq 0;$$

$$8) \frac{A^m}{A^n} = \begin{cases} A^{m-n}, & m > n \\ 1, & m = n, \quad A \neq 0 \text{ da;} \end{cases}$$

$$9) |AB| = |A| \cdot |B|;$$

$$10) |A^n| = |A|^n.$$

Ratsional ifodalarning kanonik shakli qisqarmas $\frac{P(x)}{Q(x)}$ kasrdan iborat bo'ladi. Bu yerda $P(x)$ va $Q(x)$ lar ko'phadlar bo'lib, $Q(x)$ ko'phadning bosh koeffitsiyenti esa 1 ga teng.

M i s o l. $\frac{16-x^2}{2x^2+9} : \left(\frac{1}{x-3} - \frac{1}{x-3} + \frac{x-3}{2x+1} \right)$ ratsional ifodani kanonik ko'rinishga keltiring.

$$\text{Y e c h i s h.} \quad \frac{1}{x-3} - \frac{1}{x-3} + \frac{x-3}{2x+1} = \frac{x+4}{(x-3)(2x+1)},$$

$$\frac{16-x^2}{2x^2+9} : \frac{x+4}{(x-3)(2x+1)} = \frac{(4-x)(4+x)(x-3)(2x+1)}{(2x^2+9)(x+4)} =$$

$$= \frac{-2x^2+13x^2-17x-12}{2x^2+9} = \frac{-x^3+\frac{13}{2}x^2-\frac{17}{2}x-6}{x^2+\frac{9}{2}}.$$



M a s h q l a r

5.3. O'zgaruvchining ifoda ma'noga ega bo'lmaydigan barcha qiymatlari to'plamini toping:

$$a) \frac{5-x}{x-2};$$

$$b) \frac{x^2+3}{x^2+4};$$

$$d) \frac{x+3}{(x-1)(x-2)};$$

- e) $\frac{x^2-4}{x^2-9}$; f) $\frac{3a}{3+2a}$; g) $\frac{a-4}{5}$;
- h) $\frac{a^2-5}{a-4.5}$; i) $\frac{13a+2}{26-2a}$; j) $\frac{3x}{x(x+2)}$;
- k) $\frac{x-2}{a^2-x^2}$; l) $\frac{x}{x^2-16}$; m) $\frac{y}{3y(y-5)}$;
- n) x^2+x+2 ; o) $\frac{x-1}{x} + \frac{7}{x-3}$; p) $\frac{4x}{x+5} - \frac{8x^2}{x-9}$;
- q) $\frac{31x^2}{9x-9} + x^2 - x$.

5.4. O'zgaruvchining ifoda ma'noga ega bo'ladigan barcha haqiqiy qiymatlari to'plamini tuzing:

- a) $\frac{3}{x+2}$; j) $\frac{x+4}{x-3} + \frac{1}{x+2}$;
- b) $\frac{x^3+13}{x^2+5}$; k) $\frac{7x-4}{x^2-16} + x + 2$;
- d) $\frac{x+5}{x^2-9}$; l) $\frac{x+2}{7x-7} + \frac{13}{x-2}$;
- e) $\frac{3x+5}{4x^2-9}$; m) $\frac{x^2+x-3}{x^2-5x} + \frac{1}{x}$;
- f) $\frac{11a}{13-a^2}$; n) $x^2 - x - 1$;
- g) $\frac{a+5}{4-a}$; o) $\frac{x-2}{x^2-a^2}$;
- h) $\frac{3a+13}{4a^2-1}$; p) $\frac{7}{x^2+x+1} + x^2$;
- i) $\frac{17a}{(a-1)(a-2)(a-3)}$; q) $x^2 - \frac{1}{(x-1)(x-4)}$.

5.5. Ifodaning aniqlanish sohasini toping:

- a) $\frac{2x-y}{x(x-y)}$; b) $\frac{x}{x^2-y^2}$;

d) $\frac{x+y}{x-y}$;

e) $\frac{x-2y}{x^2-y}$;

f) $\frac{x}{x-2} + \frac{y}{y(x-3)}$;

g) $\frac{x-1}{x} + \frac{y}{3x-y}$

h) $\frac{y}{x-y} - \frac{x}{x+y}$;

i) $\frac{3x+y}{x^3-y^3} - \frac{y}{3x-3}$;

j) $x + y + \frac{x}{y-4}$;

k) $xy + x^2y - \frac{y}{x+3}$;

l) $1 + x^3y + x^4y^2$;

m) $13 - 2x^2 + (x-y)^2$.

5.6. Kasrni qisqartiring:

a) $\frac{21a^3 - 6a^2b}{12ab - 42a^2}$;

b) $\frac{6m^3 - 3mn^2}{2m^3n + mn^2}$;

d) $\frac{x^2 - 2mx + 3x - 6m}{x^2 + 2mx + 3x + 6m}$;

e) $\frac{8ab + 2a - 20b - 5}{4ab - 8b^2 + a - 2b}$;

f) $\frac{16a^2 - 8ab + b^2}{16a^2 - b^2}$;

g) $\frac{9x^2 - 25y^2}{9x^2 + 30xy + 25y^2}$;

h) $\frac{a^2 - 3a}{a^2 + 3a - 18}$;

i) $\frac{4x^2 - 8x + 3}{4x^2 - 1}$;

j) $\frac{m^2 + 4m - 5}{m^2 + 7m - 10}$;

k) $\frac{x^2 + 10x + 25}{(x+5)^2}$;

l) $\frac{(x-2)^2}{(2-x)^2}$;

m) $\frac{x^6 + x^4}{x^4 + x^2}$.

Quyida keltirilgan ifodalar ratsional ifodalarmi:

5.7. a) $3x^2 + y$;

b) $3x^2 + \frac{1}{y}$;

d) $3x^2 + \frac{1}{2}$;

e) $4a^2 - x(a - 3x)$;

f) $\frac{x^2}{x-4}$;

g) $\frac{x^3}{4}$;

h) $6x - \frac{1}{2}$;

j) $\frac{xyz - \frac{1}{z}}{3 - 1\frac{1}{4}}$;

i) $\frac{x^2 + y}{1\frac{1}{2} - 0, (5)x}$;

k) $xy + \sqrt{z} - \frac{z^2}{14}$?

Amallarni bajaring (5.8 – 5.10):

5.8. a) $\frac{a-2}{2} - 1 - \frac{a-3}{3}$;

f) $c - \frac{(x+c)^2}{2x}$;

b) $\frac{a+x}{4} - a + x$;

g) $a + x \frac{a^2 + x^2}{a-x}$;

d) $4a - \frac{a-1}{4} - \frac{a+2}{3}$;

h) $\frac{a}{4x} + \frac{5}{12y} - \frac{c}{9xy^2}$;

e) $\frac{(a-x)^2}{2a} + x$;

i) $1 - \frac{x}{x-y} - \frac{1}{x+y}$;

5.9. a) $\frac{a^2}{ax-x^2} + \frac{x}{x-a}$;

f) $\frac{x-25}{5x-25} = \frac{3x+5}{5x-x^2}$;

b) $\frac{x^2 - 4xy}{2y^2 - xy} - \frac{4y}{x-2y}$;

g) $\frac{12-y}{6y-36} + \frac{6}{6y-y^2}$;

d) $\frac{x}{2a^2 - ax} + \frac{4a}{2ax - x^2}$;

h) $3x \frac{x-y}{2-x} + \frac{x+y}{4}$;

e) $\frac{4y}{3x^2 + 2xy} + \frac{9x}{3xy + 2x^2}$;

i) $\frac{x-12a}{x^2-16a^2} - \frac{4a}{4ax-x^2}$;

5.10. a) $\frac{a^2+3a}{ax-5x+8a-40}$;

b) $\frac{y}{3x-2} - \frac{3y}{6xy+9x-4y-6}$;

d) $\frac{x^2}{3ax-2-x+6a} - \frac{x}{3a-1}$;

e) $\frac{3x}{2y+3} + \frac{x^2+3x}{4xy-3-2y+6x}$;

5.11. Kasr ko'rinishida ifodalang:

a) $\frac{x^2-xy}{y} \cdot \frac{y^2}{x^3}$;

b) $\frac{3a}{b^2} \cdot \frac{ab+b^2}{9}$;

d) $\frac{x-y}{xy} \cdot \frac{2xy}{xy-y^2}$;

i) $\frac{ax+ay}{xy^2} \cdot \frac{x^2y}{3x+3y}$;

e) $\frac{4ab}{cx+bx} \cdot \frac{ax+bx}{2ab}$;

j) $\frac{xy}{a^2+a^3} \cdot \frac{a+a^2}{x^2y^2}$;

f) $\frac{xa-xy}{3c^2} \cdot \frac{2x}{cy-ca}$;

k) $\frac{6a}{x^2-x} \cdot \frac{2x-2}{3ax}$;

g) $\frac{ax-ay}{5x^2y^2} \cdot \frac{5xy}{by-bx}$;

l) $\frac{x^2-y^2}{2xy} \cdot \frac{2x}{x+y}$;

h) $\frac{kx+k^2}{k^2} \cdot \frac{x}{x+k}$;

m) $\frac{4x^2}{x^2-9} \cdot \frac{3a-ax}{4x}$.

5.12. Soddashtiring:

a) $\frac{x^2-4x}{x^2+7x} \cdot \frac{24-6x}{49-x^2}$;

f) $\frac{(x+3)^2}{2x-4} \cdot \frac{3x+9}{x^2-4}$;

b) $\frac{y^3-16y}{2y+18} \cdot \frac{4-y}{y^2+9y}$;

g) $\frac{(x-3)^2}{x-8} \cdot \frac{4x-12}{3x-24}$;

d) $\frac{(a+b)^2-2ab}{4a^2} \cdot \frac{a^2+b^2}{ab}$;

h) $\frac{a+b}{(a-b)^2} \cdot \frac{(a+b)^2}{(a-b)^3}$;

e) $\frac{5c^3-5}{c+2} \cdot \frac{(c+1)^2-c}{13c+26}$;

i) $\frac{(3c-b)^2}{3c+b} \cdot \frac{3c-b}{(3c+b)^2}$.

5.13. Ifodani soddashtiring:

a) $\left(\frac{7(m-2)}{m^3-8} - \frac{m+2}{m^2+2m+4} \right) \cdot \frac{2m^2+4m+8}{m-3}$;

b) $\frac{a+5}{a^2-9} \cdot \left(\frac{a+2}{a^2-3a+9} - \frac{2(a+8)}{a^3+27} \right)$;

d) $\left(\frac{x+2}{3x} - \frac{2}{x-2} - \frac{x-14}{3x^2-6x} \right) \cdot \frac{x+2}{6x} \cdot \frac{1}{x-5}$;

$$e) \frac{1}{2} + \left(\frac{3m}{1-3m} + \frac{2m}{3m+1} \right) \cdot \frac{9m^2 - 6m + 1}{6m^2 + 10m};$$

$$f) \left(\frac{1}{x+y} - \frac{y^2}{xy^2 - x^3} \right) : \left(\frac{x-y}{x^2+xy} - \frac{x}{x^2+xy} \right) - \frac{x}{x-y};$$

$$g) \frac{2a+3}{2a-3} \cdot \left(\frac{2a^2+3a}{4a^2+12a+9} - \frac{3a+2}{2a+3} \right) + \frac{4a-1}{2a-3} - \frac{a-1}{a};$$

$$h) \left(\frac{a+3}{a^2+2a+1} + \frac{a-1}{a^2-2a-3} \right) \cdot \frac{a^2-2a-3}{a+2} - 1;$$

$$i) \frac{3(m+3)}{m^2+3m+9} + \frac{m^2-3m}{(m+3)^2} \cdot \left(\frac{3m}{m^3-27} + \frac{1}{m-3} \right);$$

5.14. Ifodani soddalashtiring:

$$a) \left(\frac{a}{a-b} - \frac{b}{a+b} \right) : \left(\frac{a+b}{b} : \frac{a-b}{a} \right);$$

$$b) \left(2x + 1 - \frac{1}{1-2x} \right) : \left(2x - \frac{4x^2}{2x-1} \right);$$

$$d) \left(p - q + \frac{4q^2 - p^2}{p+q} \right) : \left(\frac{p}{p^2 - q^2} + \frac{2}{q-p} + \frac{1}{p+q} \right);$$

$$e) \left(\frac{2}{2x+y} - \frac{1}{2x-y} - \frac{3y}{y^2-4x^2} \right) \cdot \left(\frac{y^2}{8x^2} - \frac{1}{2} \right);$$

$$f) \left(\frac{5x+y}{x^2-5xy} + \frac{5x-y}{x^2+5xy} \right) \cdot \frac{x^2-25y^2}{x^2+y^2};$$

$$g) \frac{9a^2-16b^2}{7a} \cdot \left(\frac{3b-4a}{4b^2-3ab} - \frac{3b+4a}{4b^2+3ab} \right);$$

$$h) \frac{4xy}{y^2-x^2} : \left(\frac{1}{y^2-x^2} + \frac{1}{x^2+2xy+y^2} \right);$$

$$i) \frac{a-2}{a^2+2a} : \left(\frac{a}{a^2-2a} - \frac{a^2+4}{a^3-4a} - \frac{1}{a^2+2a} \right);$$

$$j) \frac{4a-5}{a^2 9} + \frac{9(a-3)}{15-27a+4a^2} \cdot \frac{4a^2-17a+15}{a-2} - \frac{7}{a+3};$$

$$k) (a^2 - y^2 - x^2 + 2xy) : \frac{a+y-x}{a+y+x};$$

$$l) \frac{a^2-1}{x^2+ax} \cdot \left(\frac{x}{x-1} - 1\right) \cdot \frac{a-ax^3-x^4+x}{1-a^2}, (x = -1);$$

$$m) \frac{x}{ax-2a^2} - \frac{2}{x^2+x-2ax-2a} \cdot \left(1 + \frac{3x+x^2}{x+3}\right).$$

5.15. Kasrni qisqartiring:

$$a) \frac{x^2-x+1}{x^4+x^2+1};$$

$$d) \frac{x(y-a)-y(x-a)}{x(y-a)^2-y(x-a)^2};$$

$$b) \frac{x^{14}-x^7+1}{x^{21}+1};$$

$$e) \frac{x^{33}-1}{x^{33}+x^{22}+x^{11}}.$$

5.16. k ning qanday qiymatlarida $\frac{(k-3)^2}{k}$ ifoda natural qiymatlar qabul qiladi?

5.17. Ifodani soddalashtiring va o'zgaruvchilarning ko'rsatilgan qiymatlarida ifodaning qiymatini hisoblang:

$$a) \left(\frac{x-2y}{x^3+y^3} + \frac{y}{x^3-x^2y+xy^2}\right) \cdot \frac{x^3-xy^2}{x^2+y^2} + \frac{2y^2}{x^3+x^2y+xy^2+y^3};$$

$$x = 0,2; y = 0,8;$$

$$b) \frac{1}{a(a-b)(a-c)} + \frac{1}{b(b-a)(b-c)} + \frac{1}{c(c-a)(c-b)};$$

$$a = \frac{1}{3}; b = \sqrt{3}; c = \frac{\sqrt{3}}{2}.$$

5.18. $m = a - \frac{1}{a}$ bo'lganda $a^4 + \frac{1}{a^4} = m^2(m^2 + 4) + 4$ bo'lishini isbot qiling.

5.19. Ratsional ifodalarni kanonik ko'rinishga keltiring:

$$\text{a) } \frac{2x - \frac{x+2}{x+1}}{\frac{x(x+1)}{x-1} - 1};$$

$$\text{b) } \frac{\frac{x+1}{x^2+x+1} - \frac{x-1}{x^2+x+1}}{\frac{x-1}{x^2-x+1} + \frac{x+1}{x^2-x+1}};$$

$$\text{d) } \frac{1 - \frac{1-x}{1+2x}}{1 + 2 \cdot \frac{1-x}{1+2x}};$$

$$1 + 2 \cdot \frac{1 - \frac{1-x}{1+2x}}{1 + 2 \cdot \frac{1-x}{1+2x}}$$

$$\text{e) } \frac{\frac{x-1}{x^2-x+1} + \frac{x+1}{x^2-x+1}}{1 + \frac{1-2x}{x^2+x+1}};$$

$$\text{f) } \frac{(x+1)^2 - x^4}{x^2 - (x^2-1)^2} - \frac{(x^2+1)^2 - x^2}{1 - (x(x-1))^2} = \frac{1 - (x(x+1))^2}{(x+1)^2 - x^4}.$$

2- §. Irratsional ifodalarni ayniy almashtirishlar

1. Arifmetik ildiz. Ratsional ko'rsatkichli daraja. $a \geq 0$ sonning n - darajali arifmetik ildizi deb ($n \in \mathbb{N}$), n - darajasi a ga teng bo'lgan $b \geq 0$ songa aytiladi va $b = \sqrt[n]{a}$ orqali belgilanadi. Ta'rif bo'yicha:

$$(\sqrt[n]{a})^n = a.$$

$a > 0$, $m \in \mathbb{Z}$ va $n \in \mathbb{N}$ bo'lsa, $\sqrt[n]{a^m}$ soni a ning $r = \frac{m}{n}$ ratsional ko'rsatkichli darajasi deb ataladi, ya'ni $a^r = a^{\frac{m}{n}} = \sqrt[n]{a^m}$.

$$\text{Xususan, } \sqrt[n]{a} = a^{\frac{1}{n}}.$$

Ratsional ko'rsatkichli darajaning x o s s a l a r i butun ko'rsatkichli daraja xossalariga o'xshash. a , b – ixtiyoriy musbat sonlar, r va q – ixtiyoriy ratsional sonlar bo'lsin. U holda:

$$1) \quad (ab)^r = a^r b^r \quad (1')$$

Haqiqatan, $r = m/n$, $n \in \mathbb{N}$, $m \in \mathbb{Z}$ bo'lsin. U holda:

$$\begin{aligned} ((ab)^r)^n &= \left((ab)^{\frac{m}{n}} \right)^n = \left(\sqrt[n]{(ab)^m} \right)^n = (ab)^m = a^m b^m = \\ &= \left(\sqrt[n]{a^m} \right)^n \left(\sqrt[n]{b^m} \right)^n = \left(a^{\frac{m}{n}} \cdot b^{\frac{m}{n}} \right)^n = (a^r b^r)^n, \end{aligned}$$

demak, (1') o'rinli.

Xususan,

$$\left(\frac{a}{b} \right)^r = \frac{a^r}{b^r}. \quad (2')$$

2) $a^r \cdot a^q = a^{r+q}$, bunda

$$r = \frac{k}{n}, q = \frac{m}{n}. \quad (3')$$

Haqiqatan,

$$\begin{aligned} \left(a^{\frac{k}{n}} \cdot a^{\frac{m}{n}} \right)^n &= \left(a^{\frac{k}{n}} \right)^n \cdot \left(a^{\frac{m}{n}} \right)^n = \left(\sqrt[n]{a^k} \right)^n \left(\sqrt[n]{a^m} \right)^n = a^k \cdot a^m = a^{k+m} = \\ &= \left(a^{\frac{k+m}{n}} \right)^n = \left(a^{\frac{k}{n} + \frac{m}{n}} \right)^n. \end{aligned}$$

$$3) \quad \frac{a^r}{a^q} = a^{r-q} \quad (4')$$

((2') kabi isbotlanadi).

4) $(a^r)^q = a^{r \cdot q}$, bunda

$$r = p/k, q = m/n. \quad (5')$$

Haqiqatan,

$$\left((a^{p/k})^{m/n} \right)^{nk} = \left((a^{p/k})^{m/n} \right)^n)^k = \left((a^{p/k})^m \right)^k = (a^p)^m = a^{pm} = \left(a^{\frac{pm}{kn}} \right)^{kn}.$$

Bundan (5') ning o'rinli ekani ma'lum bo'ladi.

M i s o l. $5\sqrt[3]{5} - 2^{-1} \cdot 60^{0.5} + 6$ ni hisoblang.

Y e c h i s h. $5 \cdot 0,6^{0,5} - 0,5 \cdot 10 \cdot 0,6^{0,5} + 6 = 5 \cdot 0,6^{0,5} - 5 \cdot 0,6^{0,5} + 6 = 6.$



M a s h q l a r

5.20. Ifodalar ma'noga egami:

a) $3^{-\frac{3}{4}}$; b) $(-3)^{\frac{1}{3}}$; d) $4^{\frac{1}{9}}$; e) $(-3)^{-\frac{2}{3}}$; f) $(\sqrt[3]{-4})^{\frac{1}{2}}$;

g) $(\sqrt{4})^{\frac{2}{5}}$; h) $(x-1)^{\frac{1}{3}}, (x < 1)$; i) $(x+2)^{\frac{1}{4}}, (x \geq -2)$?

5.21. O'zgaruvchining ifoda ma'noga ega bo'ladigan barcha qiymatlarini toping.

a) $4,5^{\frac{x}{2}}$, bunda $x \in Q$; b) $(-4,5)^{\frac{x}{2}}$, bunda $x \in Q$;

d) $(3+x)^{\frac{1}{5}}$; e) $(x^2+1)^{\frac{1}{3}}$; f) $(\frac{x}{2})^{-\frac{1}{4}}$;

g) $(|x|+1)^{\frac{2}{3}}$; h) $(1-|x|)^{\frac{4}{5}}$; i) $(1-|x|)^{-3}$.

5.22. Hisoblang:

a) $49^{\frac{1}{2}}$; b) $1000^{\frac{1}{3}}$; d) $4^{-\frac{1}{2}}$; e) $8^{-\frac{2}{3}}$;

f) $9^{\frac{2}{2}}$; g) $0,16^{-\frac{1}{6}}$; h) $0,008^{\frac{1}{3}}$; i) $(3\frac{3}{8})^{-\frac{4}{3}}$;

j) $9^{-1,5}$; k) $(\frac{1}{8})^{-\frac{3}{4}}$; l) $(\frac{1}{64})^{-\frac{4}{3}}$; m) $(25)^{-\frac{3}{2}}$;

n) $27^{\frac{8}{6}} \cdot 3^{2,5}$; o) $(\frac{1}{8})^{-\frac{4}{3}}$; p) $(\frac{1}{4})^{-\frac{3}{2}}$; q) $(\frac{4}{9})^{-\frac{3}{4}}$.

5.23. Ifodaning qiymatini toping:

a) $\left(\left(\frac{3}{4}\right)^0\right)^{0,5} - 7,5 \cdot 4^{-\frac{2}{3}} - (-2)^{-4} + 81^{0,25}$;

b) $0,027^{-\frac{1}{3}} - \left(-\frac{1}{6}\right)^{-2} - 256^{0,75} - 3^{-1} - (5,5)^0$;

$$d) \left(\frac{9}{16}\right)^{-\frac{1}{10}} : \left(\frac{25}{36}\right)^{-\frac{3}{2}} - \left(\left(\frac{4}{3}\right)^{-\frac{1}{2}}\right)^{-\frac{2}{5}} \cdot \left(\frac{6}{5}\right)^{-3};$$

$$e) \left(9^{-\frac{2}{3}}\right)^{\frac{3}{4}} : (25^{2.5})^{-0.1} + \left(\left(\frac{3}{4}\right)^{-1} \cdot \left(\frac{2}{9}\right)^{\frac{6}{7}}\right)^0 : 36^{-\frac{1}{2}} + \frac{1}{\sqrt{5}};$$

$$f) \left(4^{-\frac{1}{4}} + \left(\frac{1}{2^{\frac{2}{3}}}\right)^{\frac{1}{2}}\right) : \left(4^{-0.25} - (2\sqrt{2})^{-\frac{1}{2}}\right);$$

$$g) (0,04)^{-1.5} \cdot (0,125)^{-\frac{4}{3}} - \left(\frac{1}{121}\right)^{\frac{1}{2}};$$

$$h) \frac{2 \cdot 4^{-2} + \left(81^{-\frac{1}{2}}\right)^3 \cdot \left(\frac{1}{9}\right)^{-3}}{125^{-\frac{1}{3}} \cdot \left(\frac{1}{5}\right)^{-2} + (\sqrt{3})^0 \cdot \left(\frac{1}{2}\right)^{-2}}.$$

5.24. Amallarni bajaring:

$$a) c^{\frac{1}{3}} \cdot c^{\frac{1}{4}} \cdot c^{\frac{1}{12}};$$

$$f) x^{\frac{1}{2}} \cdot x^{\frac{3}{14}} \cdot x^{\frac{2}{7}};$$

$$b) b^{-0.2} : b^{-0.7};$$

$$g) (m^{0.3})^{1.2} \cdot (m^{-0.4})^{0.4};$$

$$d) (m^{0.4})^{2.5};$$

$$h) 4^{\frac{1}{3}} \cdot 2^{\frac{2}{3}} \cdot 8^{-\frac{1}{9}};$$

$$e) y^{0.8} \cdot y^{-5} \cdot y^{7.2};$$

$$i) 4^{-\frac{1}{3}} \cdot 16^{\frac{1}{3}} \cdot \sqrt[3]{4}.$$

2. Ildiz. Yuqorida arifmetik ildizga ta'rif berilgan edi. $a \geq 0$ da $x = \sqrt[n]{a}$ son $x^n = a$ tenglamaning yagona nomanfiy yechimi ekanligi, shuningdek, $a \in R$ va n – toq natural son bo'lsa, $x^n = a$ tenglamaning yagona yechimga ega ekanligi quyida isbotlanadi.

$x^n = a$ tenglamaning (bu yerda $a \in R$, $n \in N$) har qanday ildizi a sonining n -darajali ildizi deyiladi.

1- teorema. **Har qanday $a \geq 0$ haqiqiy son uchun har doim $x^n = a$ tenglikni qanoatlantiruvchi yagona $x \geq 0$ haqiqiy son mavjud.**

Isbot. Nomanfiy butun sonlarning $0, 1^n, 2^n, \dots, k^n, \dots$ n -darajalari ketma-ketligini qaraylik. Unda, albatta, n -darajasi a dan katta butun sonlar mavjud bo'ladi. Ulardan eng kichigi $(p+1)$ soni bo'lsin: $p^n \leq a < (p+1)^n$.

Endi $[p; p+1]$ oraliqni koordinatalari $p; p, 1; p, 2; \dots, p, 9; p+1$ bo'lgan nuqtalar bilan teng o'n bo'lakka ajratamiz. Bu sonlar ichida a dan kattalaridan eng kichigi $p, (q_1+1)$ bo'lsin.

$(p, q_1)^n \leq a \leq (p, (q_1+1))^n$, bunda q_1 — o'ndan birlar raqami. Bu oraliq x ning qiymatini $[p; p+1]$ oraliqqa nisbatan aniq ifodalaydi. Endi bu oraliqni o'nga bo'lamiz va ikkinchi yaqinlashishni topamiz: $(p, q_1 q_2) \leq a \leq (p, q_1(q_2+1))^n$, q_2 — yuzdan birlar raqami. Shu yo'l bilan m — qadamdan so'ng $(p, q_1 q_2 \dots q_m)^n \leq a \leq (p, q_1 q_2 \dots (q_m+1))^n$ yoki $a_1^n \leq a \leq a_2^n$ ga ega bo'lamiz. bunda a_1 orqali a ning quyi (kami bilan olingan) va a_2 orqali a ning yuqori (ortig'i bilan olingan) chegaraviy qiymatlari, ya'ni o'nli yaqinlashishlari belgilangan.

Ikkinchi tomondan, ko'paytirish qoidasiga muvofiq $a_1^n \leq x^n < a_2^n$ tengsizlikni qanoatlantiruvchi yagona x haqiqiy son mavjud. Demak, $x^n = a$. Boshqacha bo'lishi, ya'ni x dan farqli birer y uchun $y^n = a$ bo'lishi mumkin emas. Masalan, $y < x$ bo'lsa, ko'paytirishning monotonlik xossasiga muvofiq $y^n < x^n$, ya'ni $y^n < a$ bo'lardi. Shu kabi, $y > x$ bo'lganda $y^n > a$ ga ega bo'lar edik. Demak, teorema to'g'ri.

2- teorema. **Agar A natural son hech bir natural sonning n -darajasi bo'lmasa, $\sqrt[n]{A}$ soni irratsional sondir.**

Isbot. Shart bo'yicha A soni nomanfiy sonlarning

$$0^n, 1^n, 2^n, \dots, k^n, \dots$$

n -darajalar ketma-ketligida uchramaydi, demak, $\sqrt[n]{A}$ butun son emas. U kasr ham emas. Haqiqatan, $\sqrt[n]{A} = \frac{p}{q}$ bo'lsin, deb faraz qilaylik, bunda p va q lar o'zaro tub va $q \neq 1, q \neq 0$. U holda

$A = \frac{p^n}{q^n}$ va p^n va q^n — o'zaro tub, $q^n \neq 1$ bo'lganidan A soni qisqarmas kasr bo'ladi. Bu esa shartga zid. Demak, $\sqrt[n]{A}$ soni faqat irratsionaldir. Teorema isbot qilindi.

3- t e o r e m a. *Agar p/q , $q \neq 1$, qisqarmas kasrning surati va maxraji aniq n - daraja bo'lmasa, $\sqrt[n]{\frac{p}{q}}$ ildiz irratsional sonidir.*

I s b o t. Teskaricha, ildiz ratsional son, deb faraz qilaylik, ya'ni $\sqrt[n]{\frac{p}{q}} = \frac{a}{b}$, $B(a, b) = 1$. U holda $\frac{p}{q} = \frac{a^n}{b^n}$, $B(a^n, b^n) = 1$ va bundan $p = a^n$, $q = b^n$ bo'lishi kelib chiqadi. Lekin shart bo'yicha p va q n - daraja emas. Demak, $\sqrt[n]{\frac{p}{q}}$ — irratsional son. Isbot qilindi.

4- t e o r e m a. *Haqiqiy sonlar sohasida toq darajali ildiz faqat bir qiymatli va uning uchun ushbu tenglik o'rinli:*

$${}^{2n+1}\sqrt{-a} = -{}^{2n+1}\sqrt{a}.$$

I s b o t. $x^{2n+1} = a$, $a \geq 0$, (1) tenglama $\forall a \in R$ uchun yagona yechimga ega ekanligini ko'rsatamiz:

a) $a \geq 0$ bo'lsin. U holda $\forall x < 0$ son uchun $x^{2n+1} < 0 \leq a$. Demak, (1) ning, mavjudligi 1- teoremadan ko'rinadigan, $x = {}^{2n+1}\sqrt{a} \geq 0$ ildizi uning yagona haqiqiy ildizidir;

b) $a < 0$ bo'lsa, (1) ni $(-x)^{2n+1} = -a$ ko'rinishda yozib olish mumkin. $-a > 0$ bo'lgani uchun, a) holga ko'ra, oxirgi tenglama va, demak, (1) tenglama ham yagona $x = {}^{2n+1}\sqrt{-a}$ yechimga egadir.

$\forall a \in R$ uchun $x_1 = -{}^{2n+1}\sqrt{a}$ va $x_2 = {}^{2n+1}\sqrt{-a}$ sonlari (1) ning ildizlari bo'ladi. Yuqorida isbotlanganlarga ko'ra, $x_1 = x_2$. Teorema isbot qilindi.

Teoremadan ko'rinadiki, $\sqrt[n]{a^n} = a$ ayniyat n ning 1 dan katta toq natural qiymatlarida, ixtiyoriy $a \in R$ uchun o'rinli. Agar $n = 2m$ (bu yerda $m \in N$) bo'lsa, $\sqrt[2m]{a^{2m}} = \sqrt[2m]{|a|^{2m}} = |a|$ bo'ladi.

Demak, $a \geq 0$ bo'lsa, $\sqrt[2m]{a^{2m}} = a$ tenglik, $a < 0$ bo'lganda esa $\sqrt[2m]{a^{2m}} = -a$ tenglik o'rinli.

1- misol.

$$\sqrt{(-7)^2} = \sqrt{|-7|^2} = |-7| = 7, \sqrt{(-7)^2} = \sqrt{49} = 7.$$

Agar $a \leq 0$, $b \leq 0$ bo'lsa, $ab \geq 0$ va $\sqrt{ab} = \sqrt{|a||b|} = \sqrt{|a|} \cdot \sqrt{|b|}$ bo'ladi.

2- misol. $\sqrt{(-3)(-12)} = \sqrt{|-3||-12|} = \sqrt{36} = 6.$



Mashqlar

5.25. Ifodalar ma'noga egami:

a) $\sqrt[3]{-9}$;

j) $\sqrt[3]{i}$;

b) $\sqrt{-9}$;

k) $\sqrt[3]{-i}$;

d) $\sqrt[3]{9}$;

l) $\sqrt[4]{i}$;

e) $\sqrt{9}$;

m) $\sqrt[4]{-i}$;

f) $\sqrt[6]{-0,25}$;

n) $\sqrt[8]{x-y}$, bunda $x < y$;

g) $\sqrt{0,25}$;

o) $\sqrt[7]{x-y}$, bunda $x \leq y$;

h) $\sqrt[4]{-81}$;

p) $\sqrt[8]{y-x}$, bunda $x \leq y$;

i) $\sqrt[7]{-2}$;

q) $\sqrt[9]{y-x}$, bunda $x \geq y$?

5.26. Ifodalar o'zgaruvchining qanday qiymatlarida ma'noga ega:

a) $\sqrt{-x}$;

f) $\sqrt[3]{x-1}$;

j) $\sqrt[4]{-x^2 + 4\sqrt{x^2-1}}$;

b) $\sqrt[4]{x^2}$;

g) $\sqrt[5]{(x+1)^2}$;

k) $\sqrt{x^2 - 6x + 9}$;

d) $\sqrt[6]{x^2 + 4}$;

h) $\sqrt[7]{16x}$;

l) $\sqrt{x^2 + 2x + 2}$;

e) $\sqrt[8]{(x+4)^2}$;

i) $\sqrt[3]{-x+2}$;

m) $\sqrt[6]{-(x-3)^2}$?

5.27. Tengliklar o'zgaruvchining qanday qiymatlarida to'g'ri:

a) $\sqrt{(x-2)^2} = 2-x$;

h) $\sqrt{x^2-1} = -1$;

b) $\sqrt{(x+3)^2} = x+3$;

i) $\sqrt{x} = 1$;

d) $\sqrt{(x-3)^2} = x-3$;

j) $\sqrt[3]{-x} = 2$;

e) $\sqrt{(x-4)^2} = 4-x$;

k) $\sqrt[3]{-x} = -2$;

f) $\sqrt[3]{x-3} = \sqrt[3]{3-x}$;

l) $\sqrt{x^2-6x+9} = 1$;

g) $\sqrt[3]{x-3} = 0$;

m) $\sqrt[3]{x-2} = 1$?

3. Arifmetik ildizlarni shakl almashtirish. Ko'paytmaning n -darajali ildizi ko'paytuvchilar n -darajali ildizlarining ko'paytmasiga teng:

$$\sqrt[n]{ab\dots c} = \sqrt[n]{a} \cdot \sqrt[n]{b} \dots \sqrt[n]{c}, \quad (1)$$

bu yerda $a \geq 0, b \geq 0, \dots, c \geq 0$.

Haqiqatan,

$$\sqrt[n]{ab\dots c} = (ab\dots c)^{\frac{1}{n}} = a^{\frac{1}{n}} \cdot b^{\frac{1}{n}} \dots c^{\frac{1}{n}} = \sqrt[n]{a} \cdot \sqrt[n]{b} \dots \sqrt[n]{c}. \quad (2)$$

Xususan, $\sqrt[n]{a^n b} = \begin{cases} |a| \sqrt[n]{b}, & \text{agar } n - \text{juft bo'lsa,} \\ a \sqrt[n]{b}, & \text{agar } n - \text{toq bo'lsa.} \end{cases}$

Ko'paytuvchini ildiz ishorasi ostiga kiritish:

$$a \sqrt[n]{b} = \sqrt[n]{a^n b}, \quad (a \geq 0, b \geq 0). \quad (3)$$

Kasrdan ildiz chiqarish:

$$\sqrt[n]{\frac{a}{b}} = \frac{\sqrt[n]{a}}{\sqrt[n]{b}}, \quad (a \geq 0, b \geq 0). \quad (4)$$

Ildizni darajaga ko'tarish uchun ildiz ostidagi ifodani shu darajaga ko'tarish kifoya:

$$\left(\sqrt[n]{a}\right)^m = \sqrt[n]{a^m}, \quad (a \geq 0). \quad (5)$$

Haqiqatan, $\left(\sqrt[n]{a}\right)^m = \left(a^{\frac{1}{n}}\right)^m = a^{m \cdot \frac{1}{n}} = \left(a^m\right)^{\frac{1}{n}} = \sqrt[n]{a^m}$.

a sonning m - darajasining n - darajali ildizini topish uchun a ning n - darajali ildizini m - darajaga ko'tarish kifoya, ya'ni

$$\sqrt[n]{a^m} = \left(\sqrt[n]{a}\right)^m, \quad (a > 0). \quad (6)$$

Ildizdan ildiz chiqarish uchun ildiz ostidagi ifoda o'zgartirilmay qoldiriladi, ildizlar ko'rsatkichlari esa ko'paytiriladi:

$$\sqrt[n]{\sqrt[m]{a}} = \sqrt[nm]{a}, \quad (a \geq 0). \quad (7)$$

Haqiqatan, $\sqrt[n]{\sqrt[m]{a}} = \left(\left(a^{\frac{1}{m}}\right)^{\frac{1}{n}}\right) = a^{\frac{11}{mn}} = a^{\frac{1}{mn}} = \sqrt[nm]{a}$.

Har xil ko'rsatkichli $\sqrt[n]{a}$, $\sqrt[m]{b}$, ..., $\sqrt[k]{c}$ ildizlarni bir xil ko'rsatkichli ildizlarga aylantirish uchun n , m , ..., k sonlarining umumiy karralisi (bo'linuvchisi) bo'lgan α soni topiladi. $\alpha = nu = mv = \dots = kw$ bo'lsin, bunda u , v , ..., w — qo'shimcha ko'paytuvchilar. Natijada ildizlar quyidagi ko'rinishga keladi:

$$\sqrt[\alpha]{a^u}, \sqrt[\alpha]{b^v}, \dots, \sqrt[\alpha]{c^w}.$$

M i s o l. $\sqrt[8]{10} > \sqrt[4]{3}$, chunki $\sqrt[8]{10} > \sqrt[8]{3^2}$, $10 > 9$.



M a s h q l a r

5.28. Ko'paytmadan ildiz chiqaring:

a) $\sqrt{16 \cdot 121}$;

b) $\sqrt[3]{-125 \cdot 27}$;

- d) $\sqrt[4]{16 \cdot 81}$; e) $\sqrt[5]{32 \cdot 243}$;
 f) $\sqrt{9 \cdot 25 \cdot 36 \cdot 49}$; g) $\sqrt[3]{8 \cdot 27 \cdot 64 \cdot 125}$;
 h) $\sqrt[4]{81 \cdot 625 \cdot 256}$; i) $\sqrt{0,01 \cdot 0,09 \cdot 0,25}$.

5.29. Bo'linmadan ildiz chiqaring:

- a) $\sqrt{\frac{36}{49}}$; b) $\sqrt[3]{-\frac{64}{27}}$; d) $\sqrt[4]{\frac{16}{81}}$; e) $\sqrt[5]{\frac{243}{32}}$; f) $\sqrt{\frac{25}{64}}$;
 g) $\sqrt[3]{\frac{64}{125}}$; h) $\sqrt[4]{\frac{81}{625}}$; i) $\sqrt{\frac{0,01}{0,09}}$.

5.30. Darajadan ildiz chiqaring:

- a) $\sqrt[4]{15^8}$; b) $\sqrt[4]{(-15)^8}$; d) $\sqrt[3]{-5^6}$; e) $\sqrt{\left(\frac{1}{3}\right)^4}$;
 f) $\sqrt[4]{x^4}$, bunda, $x \geq 0$; g) $\sqrt[3]{x^6}$, bunda $x \in R$;
 h) $\sqrt{(x^2 + 1)^2}$, bunda $x \in R$;
 i) $\sqrt{x^6}$, bunda $x \geq 0$.

5.31. Ildizdan ildiz chiqaring:

- a) $\sqrt[3]{\sqrt{16}}$; b) $\sqrt[4]{\sqrt{76}}$; d) $\sqrt[5]{\sqrt{4}}$; e) $\sqrt[7]{\sqrt{25}}$;
 f) $\sqrt[7]{\sqrt{x^2}}$, bunda $x \geq 0$; g) $\sqrt[3]{\sqrt{x}}$, bunda $x \geq 0$;
 h) $\sqrt[3]{\sqrt[4]{x}}$, bunda $x \geq 0$; i) $\sqrt[3]{\sqrt[3]{x}}$, bunda $x \in R$.

5.32. Ildizni darajaga ko'taring:

- a) $(\sqrt[4]{2})^3$; b) $(\sqrt[6]{16})^3$; d) $(\sqrt[3]{-2})^5$; e) $(\sqrt[4]{4})^2$;
 f) $(\sqrt[4]{x})^3$; g) $(\sqrt[4]{x^2})^6$; h) $(\sqrt[4]{x+2})^5$; i) $(\sqrt[3]{x^4})^6$.

5.33. Berilgan ildizlarni bir xil ko'rsatkichli ildizlarga aylantiring:

- a) $\sqrt{3} \text{ va } \sqrt[3]{4}$; b) $\sqrt[3]{2} \text{ va } \sqrt[4]{4}$;
 d) $\sqrt{5} \text{ va } \sqrt[4]{6}$; e) $\sqrt[5]{2} \text{ va } \sqrt[3]{3}$;
 f) $\sqrt{x} \text{ va } \sqrt[8]{y}$; g) $\sqrt[3]{x+1} \text{ va } \sqrt[7]{y}$;
 h) $\sqrt{x^2+1} \text{ va } \sqrt[6]{y^2-1}$; i) $\sqrt[5]{x-y} \text{ va } \sqrt[4]{y}$.

5.34. Ko'paytuvchini ildiz belgisi ostidan chiqaring:

- a) $\sqrt{12}$; f) $\sqrt{98}$; j) $\sqrt{(x^2-2)^2 \cdot y}$;
 b) $\sqrt[4]{1250}$; g) $\sqrt[3]{375}$; k) $\sqrt[4]{x^4 y^3}$;
 d) $\sqrt[3]{81}$; h) $\sqrt[4]{48}$; l) $\sqrt[7]{(x-1)^7 z^2}$;
 e) $\sqrt[3]{24}$; i) $\sqrt{243}$; m) $\sqrt[5]{(y+1)^{10} x^2}$.

5.35. Ko'paytuvchini ildiz belgisi ostiga kiriting:

- a) $4\sqrt{5}$; h) $x^2 \sqrt[4]{y^3}$, bunda $x \leq 0$;
 b) $-3\sqrt[3]{2}$; i) $x^3 \sqrt[4]{y^5}$, bunda $x \leq 0$;
 d) $-3\sqrt[4]{2}$; j) $(x-1)^2 \sqrt[4]{y-2}$, bunda $x \leq 1$;
 e) $2\sqrt[5]{3}$; k) $(x-1)^3 \sqrt[4]{y-2}$, bunda $x \leq 1$;
 f) $x\sqrt{y^3}$, bunda $x \leq 0$; l) $-x\sqrt[4]{y}$, bunda $x \geq 0$;
 g) $x\sqrt[5]{y^3}$, bunda $x \leq 0$; m) $(\sqrt{3}-2)\sqrt{xy^3}$.

5.36. Hisoblang:

- a) $\sqrt{18} + \sqrt{50} - \sqrt{98}$;
 b) $\sqrt[3]{81} - \sqrt[3]{24} + \sqrt[3]{375}$;
 d) $2\sqrt{3} - \sqrt{27} + 3\sqrt{12} - 2\sqrt{243}$;

- e) $\sqrt{50} - 5\sqrt{8} + \sqrt{2} + \sqrt{128}$;
 f) $\sqrt{2} + 3\sqrt{32} + 0,5\sqrt{128} - 6\sqrt{18}$;
 g) $\sqrt[3]{2} + \sqrt[3]{250} - \sqrt[3]{686} - \sqrt[3]{16}$;
 h) $20\sqrt{245} - \sqrt{5} + \sqrt{125} - 2,5\sqrt{180}$;
 i) $2\sqrt{3} + \sqrt{192} - 2\sqrt{75} + \sqrt[4]{128}$.

5.37. Soddashtiring:

- a) $\sqrt[3]{16\sqrt{2}}$; e) $\sqrt[4]{12\sqrt{9^3\sqrt{4}}}$; h) $\sqrt{\frac{a+1}{a-1}} \sqrt{\frac{a-1}{a+1}}$;
 b) $\sqrt{5^3\sqrt{625}}$; f) $\sqrt[5]{2^4\sqrt[4]{3^3\sqrt{8}}}$; i) $\sqrt[3]{2\sqrt{2^3\sqrt{2}}}$.
 d) $\sqrt[3]{3^4\sqrt[3]{3^5\sqrt{3}}}$; g) $\sqrt{\frac{2+\sqrt{2}}{2-\sqrt{2}}} \sqrt{\frac{2-\sqrt{2}}{2+\sqrt{2}}}$;

5.38. Sonlarni taqqoslang:

- a) $2\sqrt{3}$ va $3\sqrt{2}$; f) $\sqrt{2}$ va $\sqrt[3]{3}$;
 b) $2^3\sqrt{3}$ va $3^3\sqrt{2}$; g) $\sqrt[3]{12}$ va $\sqrt{5}$;
 d) $5\sqrt{7}$ va $8\sqrt{3}$; h) $\sqrt{8}$ va $\sqrt[3]{19}$;
 e) $3^3\sqrt{4}$ va $3^3\sqrt{2}$; i) $^{12}\sqrt{2}$ va $^{15}\sqrt{3}$.

5.39. Ifodaning qiymatlarini toping:

- a) $\sqrt{2} \cdot \sqrt{5} \cdot \sqrt{40}$; f) $\sqrt{2} \cdot \sqrt{6} \cdot \sqrt{3}$;
 b) $\sqrt[4]{2} \cdot \sqrt[6]{32}$; g) $\sqrt{7} \cdot \sqrt[3]{6} \cdot \sqrt[6]{2}$;
 d) $\sqrt[5]{a^2} \cdot \sqrt[15]{a^4}$, $a = 3$; h) $\sqrt[3]{a} \cdot \sqrt{5}$, $a = 2$;
 e) $\sqrt[3]{a^2} \cdot \sqrt[4]{a}$, $a = 2$; i) $\sqrt[4]{x} \cdot \sqrt{y}$, $x = 3$, $y = 2$.

5.40. Ifodani soddalashtiring:

- a) $\frac{\sqrt[3]{4}}{\sqrt{2}}$; b) $\frac{\sqrt[3]{8}}{\sqrt[3]{2}}$; d) $\frac{\sqrt{24}}{\sqrt{4}}$;
 e) $\frac{\sqrt[3]{2}}{\sqrt[4]{3}}$; f) $12\sqrt{a^2} : 4\sqrt{a}$; g) $\sqrt[9]{a^8} : \sqrt[6]{a^5}$;
 h) $\frac{\sqrt[4]{2^7}}{\sqrt[3]{2^4}}$; i) $\frac{\sqrt[14]{3^9}}{\sqrt[9]{3^2}}$.

5.41. Darajaga ko'taring:

- a) $(\sqrt[3]{4x^2})^2$; f) $(a^2x\sqrt[3]{3a^2x})^4$;
 b) $(2\sqrt[3]{3x^2})^3$; g) $(\sqrt[3]{2+xy^2})^2$;
 d) $(3\sqrt{4x^2-1})^2$; h) $(\sqrt{xy+z})^3$;
 e) $(\sqrt[3]{x^8})^6$; i) $(\sqrt[6]{xy})^2$.

5.42. Kasr maxrajidagi irratsionallikni yo'qoting:

- a) $\frac{2}{\sqrt{3}}$; g) $\frac{1}{\sqrt{5}}$; l) $\frac{2}{\sqrt{a+\sqrt{x}}}$;
 b) $\frac{5}{\sqrt[3]{12}}$; h) $\frac{2}{\sqrt[3]{75}}$; m) $\frac{a}{\sqrt[3]{a+\sqrt[3]{x}}}$;
 d) $\frac{\sqrt{3}+\sqrt{2}}{\sqrt{3}-\sqrt{2}}$; i) $\frac{\sqrt{7}-\sqrt{6}}{\sqrt{7}+\sqrt{6}}$; n) $\frac{x-y}{\sqrt{x+y}}$;
 e) $\frac{4}{1+\sqrt{3}-\sqrt{2}}$; j) $\frac{12}{3+\sqrt{2}-\sqrt{5}}$; o) $\frac{1-a}{\sqrt{1-\sqrt{a}}}$;
 f) $\frac{\sqrt[3]{5}+\sqrt[3]{3}}{\sqrt[3]{5}-\sqrt[3]{3}}$; k) $\frac{15}{\sqrt[3]{3}+\sqrt[3]{7}}$; p) $\frac{x+y}{\sqrt{x-y}}$.

5.43. Hisoblang:

$$a) \frac{1}{\sqrt{3}+\sqrt{2}} + \frac{1}{\sqrt{4}+\sqrt{3}} + \frac{1}{\sqrt{5}+\sqrt{4}} + \dots + \frac{1}{\sqrt{37}+\sqrt{36}};$$

$$b) \frac{1}{\sqrt{7}+\sqrt{6}} + \frac{1}{\sqrt{8}+\sqrt{7}} + \frac{1}{\sqrt{9}+\sqrt{8}} + \dots + \frac{1}{\sqrt{23}+\sqrt{22}};$$

$$d) \frac{1}{\sqrt{3}-\sqrt{2}} + \frac{1}{2-\sqrt{3}} - \sqrt{2} - 2\sqrt{3};$$

$$e) \frac{3}{\sqrt{5}-\sqrt{2}} + \frac{5}{\sqrt{7}+\sqrt{2}} - \sqrt{7} - \sqrt{5}.$$

5.44. Tenglik to'g'rimi:

$$a) \frac{3}{\sqrt{6}-\sqrt{3}} + \frac{4}{\sqrt{7}+\sqrt{3}} = \frac{1}{\sqrt{7}-\sqrt{6}};$$

$$b) -\frac{2}{\sqrt{8}+\sqrt{6}} + \frac{5}{\sqrt{11}+\sqrt{6}} = -\frac{3}{\sqrt{8}+\sqrt{11}};$$

$$d) \frac{8\sqrt{7}}{\sqrt{5}\sqrt{7}-\sqrt{2}\sqrt{7}} + \frac{4\sqrt{7}}{\sqrt{5}\sqrt{7}+\sqrt{8}\sqrt{7}} = -4\sqrt[4]{175};$$

$$e) \frac{4\sqrt{5}}{\sqrt{3}\sqrt{5}-\sqrt{2}\sqrt{5}} - \frac{5\sqrt{5}}{4\sqrt{2}\sqrt{5}-3\sqrt{3}\sqrt{5}} = -\sqrt[4]{45}?$$

4. Irratsional ifodalarni soddalashtirish. Sonlar, harflar va algebraik amallar (qo'shish, ayirish, ko'paytirish, bo'lish, darajaga ko'tarish va ildiz chiqarish) bilan tuzilgan ifoda *algebraik ifoda* deyiladi. Ildiz chiqarish amali qatnashgan ifoda shu argumentga nisbatan *irratsional ifoda* deyiladi. Masalan, $3 - \sqrt{5}$, $\sqrt{5 + \sqrt{a}}$,

$\sqrt{a^2 - \sqrt{ab}}$ ifodalar irratsional ifodalardir.

Irratsional ifodalar ustida amallar arifmetik amallar qonunlariga va ildizlar ustida amal qoidalariga muvofiq bajariladi.

1- m i s o l. Darajani ildiz ostidan chiqarishda daraja ko'rsatkichi ildiz ko'rsatkichiga bo'linadi. Chiqqan bo'linma va qoldiq mos tartibda

ildiz ostidan chiqqan va ildiz ostida qolgan sonlarning daraja ko'rsatkichlarini beradi, $\sqrt[5]{a^7 b^9 c^{-10}} = abc^{-2} \sqrt[5]{a^2 b^4}$.

2- misol. $a^u b^v \dots c^w$ ifodali maxrajni m - darajali ildiz ostidan chiqarish (kasrni irratsionallikdan qutqazish) uchun ildiz ostidagi kasrning surat va maxraji $a^{m-u} b^{m-v} \dots c^{m-w}$ ga ko'paytirilishi kifoya:

$$x = \frac{\sqrt[3]{a^5}}{\sqrt{c^u d^v}} = \frac{\sqrt[3]{a^5 \cdot c^{3-u} d^{3-v}}}{\sqrt{c^u d^v \cdot c^{3-u} d^{3-v}}} = \frac{\sqrt[3]{a^5 \cdot c^{3-u} d^{3-v}}}{c^3 d^3} = \frac{1}{cd} \sqrt[3]{a^5 c^{3-u} d^{3-v}}$$

3- misol. $\sqrt[n]{a} (a \geq 0)$ ildizni m - darajaga ko'taramiz: $(\sqrt[n]{a})^m = \sqrt[n]{a^m}$. Agar $m = kn + l$ bo'lsa, $\sqrt[n]{a^{kn+l}} = a^k \sqrt[n]{a^l}$ bo'ladi.

4- misol. O'xshash ildizlarni keltiramiz:

$$a^n \sqrt[n]{A} + b^m \sqrt[m]{B} + c^n \sqrt[n]{A} + d^n \sqrt[n]{A} = (a + c + d) \sqrt[n]{A} + b^m \sqrt[m]{B}$$

5- misol. Ildizlarni ko'paytirish va bo'lish:

$$\sqrt[m]{A} \cdot \sqrt[n]{B} = \sqrt[mn]{A^n} \cdot \sqrt[nm]{B^m} = \sqrt[mn]{A^n B^m}; \quad \frac{\sqrt[n]{A}}{\sqrt[n]{B}} = \sqrt[n]{\frac{A^n}{B^n}}$$

6- misol. Murakkab kvadrat ildizni almashtirish

$$\sqrt{A \pm \sqrt{B}} = \sqrt{\frac{A + \sqrt{A^2 - B}}{2}} \pm \sqrt{\frac{A - \sqrt{A^2 - B}}{2}}, \quad (1)$$

$$A > 0, B > 0, A^2 > B$$

formulasini isbotlaymiz.

Isbot. $x = \sqrt{A + \sqrt{B}} + \sqrt{A - \sqrt{B}}$ belgilashni kiritib, uni

kvadratga ko'tarsak: $x^2 = 2A + 2\sqrt{A^2 - B}$, $x = \sqrt{2A + 2\sqrt{A^2 - B}}$.

U holda $\sqrt{A + \sqrt{B}} + \sqrt{A - \sqrt{B}} = \sqrt{2A + 2\sqrt{A^2 - B}}$. Shu kabi

$\sqrt{A + \sqrt{B}} - \sqrt{A - \sqrt{B}} = 2\sqrt{\frac{A - \sqrt{A^2 - B}}{2}}$. Keyingi ikki tenglikni qo'sh-sak va ayirsak, (1) formula hosil bo'ladi.

$S = \sqrt[3]{A} + \sqrt[3]{B}$ irratsional ifodadagi ildizlarni yo'qotish uchun $x^3 + y^3 = (x + y)(x^2 - xy + y^2)$ ayniyatdan foydalanish mumkin. Bizda $x = \sqrt[3]{A}$, $y = \sqrt[3]{B}$. Shunga ko'ra S ni $M = \sqrt[3]{A^2} - \sqrt[3]{AB} + \sqrt[3]{A^2}$ ifodaga ko'paytirish kerak bo'ladi.

7- misol. $x = \sqrt{5} - \sqrt{3 - \sqrt{29 - 12\sqrt{5}}}$ ifodani soddalashtiramiz.

Yechish. Oldin kvadrat ildizlar ostidagi ifodalarning musbat ekanini, ya'ni ildizlar haqiqiy sonlar sohasida ma'noga egaligini bilishimiz kerak.

$$\begin{aligned} \text{a) } 29 - 12\sqrt{5} > 0 \text{ (?) } &\Rightarrow 29 > 12\sqrt{5} \text{ (?) } \Rightarrow \\ &\Rightarrow 841 > 144 \cdot 5 \text{ (?) } \Rightarrow 841 > 720 \text{ (!);} \end{aligned}$$

$$\begin{aligned} 3 - \sqrt{29 - 12\sqrt{5}} > 0 \text{ (?) } &\Rightarrow 3 > \sqrt{29 - 12\sqrt{5}} \text{ (?) } \Rightarrow 9 > 29 - \\ &- 12\sqrt{5} \text{ (?) } \Rightarrow 12\sqrt{5} > 29 - 9 = 20 \text{ (?) } \Rightarrow 720 > 400 \text{ (!);} \end{aligned}$$

$$\begin{aligned} \sqrt{5} - \sqrt{3 - \sqrt{29 - 12\sqrt{5}}} > 0 \text{ (?) } &\Rightarrow \\ &\Rightarrow 5 > 3 - \sqrt{29 - 12\sqrt{5}} \text{ (?) } \Rightarrow 2 + \sqrt{29 - 12\sqrt{5}} > 0 \text{ (!)} \end{aligned}$$

Demak, haqiqiy sonlar sohasida almashtirishlarni bajarish mumkin;

b) murakkab ildiz formulasidan foydalanamiz:

$$\begin{aligned} \sqrt{29 - 12\sqrt{5}} &= \sqrt{29 - \sqrt{720}} = \sqrt{\frac{29 + \sqrt{841 - 720}}{2}} - \\ &- \sqrt{\frac{29 - \sqrt{841 - 720}}{2}} = \sqrt{20} - 3; \end{aligned}$$

$$\sqrt{3 - (\sqrt{20} - 3)} = \sqrt{6 - \sqrt{20}} = \sqrt{\frac{6 + \sqrt{36 - 20}}{2}} -$$

$$- \sqrt{\frac{6 - \sqrt{36 - 20}}{2}} = \sqrt{5} - 1, x = \sqrt{5} - (\sqrt{5} - 1) = 1.$$

8- misol. x ning qanday qiymatlarida $\sqrt{(x-8)^2} = x-8$ tenglik o'rinli bo'lishini aniqlaymiz.

Yechish. $\sqrt{(x-8)^2} = |x-8|$ bo'lgani uchun, berilgan tenglik $x-8 \geq 0$ bo'lganda, ya'ni $x \in [8; +\infty)$ larda o'rinli bo'ladi.

9- misol. x ning qanday qiymatlarida $\sqrt{x-3}\sqrt{x+3} = \sqrt{x^2-9}$ tenglik o'rinli bo'lishini aniqlaymiz.

Yechish. x ning $x-3 < 0$ yoki $x+3 < 0$ bo'ladigan qiymatlarida tenglikning chap tomoni ma'noga ega emas. Shu sababli x ning $x-3 \geq 0$ va $x+3 \geq 0$ tengsizliklar bajariladigan qiymatlarini, ya'ni $x \geq 3$ bo'lgan holni qaraymiz.

$x \geq 3$ bo'lsa, arifmetik ildizlarni ko'paytirish qoidasi (3-band, (1) tenglik) ga asosan, $\sqrt{x-3} \cdot \sqrt{x+3} = \sqrt{(x-3)(x+3)} = \sqrt{x^2-9}$ tenglikka ega bo'lamiz. Shunday qilib, berilgan tenglik $x \in [3; +\infty)$ lar uchun o'rinli.



M a s h q l a r

5.45. Murakkab ildiz formulalaridan foydalanib, ifodalarni soddalashtiring:

a) $\sqrt{5 + 2\sqrt{6}}$;

d) $\sqrt{10 - 2\sqrt{21}}$;

b) $\sqrt{6 - \sqrt{20}}$;

e) $\sqrt{4\sqrt{2} + 2\sqrt{6}}$.

5.46. Darajaga ko'taring:

$$\left(\frac{2+\sqrt{3}}{\sqrt{2}+\sqrt{2+\sqrt{3}}} + \frac{2-\sqrt{3}}{\sqrt{2}-\sqrt{2-\sqrt{3}}} \right)^2.$$

5.47. Ifodani soddalashtiring:

a) $\left(\sqrt{ab} - \frac{ab}{a+\sqrt{ab}} \right) : \frac{\sqrt[4]{ab}-\sqrt{b}}{a-b};$

b) $\left(\frac{(\sqrt{a}+1)^3 - a\sqrt{a}+2}{(\sqrt{a}+1)^2 - \frac{a-\sqrt{ax}}{\sqrt{a}-\sqrt{x}}} \right);$

d) $\left(\frac{\sqrt{a+1}}{\sqrt{1+a}-\sqrt{1-a}} + \frac{1-a}{\sqrt{1-a^2}+a-1} \right) \cdot \left(\sqrt{\frac{1}{a^2}-1-\frac{1}{a}} \right);$

e) $\frac{(\sqrt{a}-\sqrt{b})^3 + 2a^2 : \sqrt{a+b}\sqrt{b}}{a\sqrt{a+b}\sqrt{b}} + \frac{3\sqrt{ab}-3b}{a-b};$

f) $\frac{\frac{a+x}{\sqrt[3]{a^2-\sqrt[3]{x^2}}} + \frac{\sqrt[3]{ax^2}-\sqrt[3]{a^2x}}{\sqrt[3]{a^2-2\sqrt[3]{ax}+\sqrt[3]{x^2}}}}{\sqrt[6]{a}-\sqrt[6]{x}};$

g) $\left(\frac{4a-9a^{-1}}{2a^{\frac{1}{2}}-3a^{-\frac{1}{2}}} + \frac{a-4+\frac{3}{a}}{a^{\frac{1}{2}}-a^{-\frac{1}{2}}} \right)^2;$

h) $\left(\frac{3x^{-\frac{1}{3}}}{x^{\frac{2}{3}}-2x^{-\frac{1}{3}}} - \frac{x^{\frac{1}{3}}}{x^{\frac{4}{3}}-x^{\frac{1}{3}}} \right)^{-1} - \left(\frac{1-2x}{3x-2} \right)^{-1};$

i) $\left(a+b^{\frac{3}{2}} : \sqrt{a} \right)^{\frac{2}{3}} \cdot \left(\frac{\sqrt{a}-\sqrt{b}}{\sqrt{a}} + \frac{\sqrt{b}}{\sqrt{a}-\sqrt{b}} \right)^{-\frac{2}{3}}.$

5.48. $x = \frac{\sqrt{3}}{2}$ bo'lsa, $\frac{1+x}{1+\sqrt{1+x}} + \frac{1-x}{1-\sqrt{1-x}}$ ifodaning qiymatini toping.

5.49. $x = 13$, $y = 5$ bo'lsa, $\left(x + y^{\frac{3}{2}} : \sqrt{x}\right)^{\frac{2}{3}} \cdot \left(\frac{\sqrt{x}-\sqrt{y}}{\sqrt{x}} + \frac{\sqrt{y}}{\sqrt{x}-\sqrt{y}}\right)$ ifodaning qiymatini toping.

5.50. Ayniyatni isbotlang:

a) $\frac{a^{\frac{1}{2}}+1}{a+a^{\frac{1}{2}}+1} : \frac{1}{a^{\frac{3}{2}}-1} - a = -1;$

b) $\left(\frac{(a+\sqrt[3]{a^2x}) : (x+\sqrt[3]{ax^2}) - 1}{\sqrt[3]{a} + \sqrt[3]{x}} - \frac{1}{\sqrt[3]{x}}\right)^6 = \frac{a^2}{x^4}.$



VI bob

ALGEBRAIK TENGLAMALAR VA TENGSIZLIKLAR

1- §. Bir o'zgaruvchili tenglamalar

1. Tenglama. Teng kuchli tenglamalar. Bir o'zgaruvchili $A(x)$ va $B(x)$ ifodalardan tuzilgan

$$A(x) = B(x) \quad (1)$$

tenglik *bir o'zgaruvchili tenglama*, x ning uni to'g'ri sonli tenglikka aylantiruvchi har qanday qiymati esa shu *tenglamaning yechimi (ildizi)* deb ataladi.

Bir o'zgaruvchili tenglama yechimga ega bo'lmasligi, bitta yoki bir nechta ildizga ega bo'lishi, yoki cheksiz ko'p ildizlarga ega bo'lishi mumkin.

Masalan, $x^2 + 4 = 0$ tenglama yechimga ega emas, $x + 4 = 0$ tenglama bitta ($x = -4$) yechimga ega, $(x + 1)(x - 2)(x + 3) = 0$ tenglama uchta ($x = -1$, $x = 2$, $x = -3$) yechimga ega va nihoyat, $0 \cdot x = 0$ tenglama cheksiz ko'p yechimga egadir.

Tenglamani yechish uning *barcha ildizlari to'plamini* topish demakdir. Agar $A_1(x) = B_1(x)$ tenglamaning yechimlari to'plami $A_2(x) = B_2(x)$ tenglamaning yechimlari to'plamiga teng bo'lsa, ular *teng kuchli tenglamalar* deyiladi. Bundan, yechimga ega bo'lmagan har qanday ayni bir o'zgaruvchili tenglamalarning teng kuchli ekanligi kelib chiqadi.

1- misol. $x^2 - 5x + 6 = 0$ va $(x - 2)(x - 3) = 0$ tenglamalar teng kuchli tenglamalar ekanligini ko'rsatamiz.

$x^2 - 5x + 6 = 0$ kvadrat tenglama $x_1 = 2$, $x_2 = 3$ ildizlarga ega. Uning yechimlar to'plami $X_1 = \{2; 3\}$ dan iborat.

$(x - 2)(x - 3) = 0$ tenglama ham $x_1 = 2$, $x_2 = 3$ ildizlarga ega. Shu sababli uning yechimlari to'plami $X_2 = \{2; 3\}$ dan iborat. Bundan $X_1 = X_2$ ga ega bo'lamiz. Demak, berilgan tenglamalar teng kuchlidir.

2- misol. $x^2 - 5x + 6 = 0$ va $\frac{x-2}{x-3} = 0$ tenglamalar teng

kuchli tenglamalar emas (ishonch hosil qiling!).

x o'zgaruvchining $A(x)$ ifoda ma'noga ega bo'ladigan barcha qiymatlari to'plami $A(x)$ ifodaning aniqlanish sohasini (mavjudlik sohasini) tashkil etadi. $A(x)$ va $B(x)$ ifodalar aniqlanish sohalarining umumiy qismi $A(x) = B(x)$ tenglamaning *aniqlanish sohasi* (x o'zgaruvchining joiz qiymatlari sohasi) deb ataladi.

Tenglamaning yechimlar to'plami uning aniqlanish sohasining qism to'plami bo'lib, unga teng bo'lishi shart emas.

Masalan, $\sqrt{-(x-1)^2} = 0$ tenglamaning yechimlar to'plami ham, aniqlanish sohasi ham $\{1\}$ to'plamdan iborat, lekin $x^2 - 5x + 6 = 0$ tenglamaning (1- misolga qarang) yechimlar to'plami $\{2; 3\}$ dan, aniqlanish sohasi esa $R = (-\infty; +\infty)$ dan iboratdir.

Endi tenglamalarning teng kuchliligi haqidagi ba'zi teoremlarni keltiramiz.

1- teorema. *Agar $C(x)$ ifoda barcha $x \in X$ da aniqlangan bo'lsa, $A(x) + C(x) = B(x) + C(x)$ (2) va (1) tenglamalar teng kuchli bo'ladi, bu yerda $X - (1)$ tenglamaning aniqlanish sohasi.*

Isbot. α soni (1) tenglamaning ildizi bo'lsin. U holda $A(\alpha) = B(\alpha)$ chin sonli tenglik hosil bo'ladi. Ikkinchi tomondan, $\alpha \in X$ ekanligidan $C(\alpha)$ soni mavjud va shunga ko'ra $A(\alpha) + C(\alpha) = B(\alpha) + C(\alpha)$ ham chin tenglik. Demak, $x = \alpha$ soni (2) tenglamaning ham ildizi. (2) ning har bir ildizi (1) uchun ham ildiz bo'lishi shu kabi ko'rsatiladi.

Teoremadan ko'rinadiki $A(x) = B(x)$ tenglamani unga teng kuchli bo'lgan $f(x) = 0$ ko'rinishdagi tenglama bilan almashtirish mumkin.

2- teorema. *Agar $C(x)$ ifoda barcha $x \in X$ qiymatlarda noldan farqli qiymatlar qabul qilsa, (1) tenglama $A(x)C(x) = B(x)C(x)$ tenglamaga teng kuchli bo'ladi, bu yerda $X - (1)$ tenglamaning aniqlanish sohasi.*

Bu teorema 1- teorema kabi isbotlanadi: $A(\alpha) = B(\alpha)$ tenglikdan $A(\alpha)C(\alpha) = B(\alpha)C(\alpha)$ tenglik kelib chiqadi, keyingi tenglikdan esa $C(\alpha) \neq 0$ bo'lganidan $A(\alpha) = B(\alpha)$ tenglik hosil bo'ladi.

Ko'paytirishda (demak, bo'lishda ham) $C(x) \neq 0$ bo'lishi muhim. Aks holda, *chet ildizlar* paydo bo'lishi mumkin.

Tenglama ikkala qismiga x ning ayrim qiymatlarida sonli qiymatga ega bo'lmaydigan ifoda qo'shilsa yoki ikkala qism shunday ifodaga ko'paytirilsa, ildiz yo'qolishi mumkin.

3- m i s o l. $(2x + 1)(x^2 + 3) + x^3 = (x - 3)(x^2 + 3) + x^3$ va $2x + 1 = x - 3$ tenglamalar teng kuchli, chunki R to'plamda $x^2 + 3$ ko'paytuvchi noldan farqli, x^3 qo'shiluvchi esa barcha R da aniqlangan.

4- m i s o l. $\frac{(x - 2)(x + 2)}{x + 2} = -4$ va $x - 2 = -4$ tenglamalar teng kuchli emas, chunki $x = -2$ da birinchi tenglama ma'noga ega emas, ikkinchi tenglama esa ma'noga ega va to'g'ri sonli tenglikka aylanadi. $x - 2 = -4$ tenglamaning yagona ildizidir.

5- m i s o l. $x^2 - 9 = x - 3$ tenglamaning ildizlari $x_1 = -2$ va $x_2 = 3$. Agar tenglamaning ikkala qismi $x - 3$ ga bo'linsa, unga teng kuchli bo'lmagan $x + 3 = 1$ tenglama hosil bo'ladi. Chunki, uning faqat bitta, ya'ni $x = -2$ ildizi mavjud. Bu yerda, tenglamani o'zgaruvchili ifodaga bo'lish natijasida, berilgan tenglamaning $x = 3$ dan iborat ildizi yo'qolganini ko'ramiz.



Mashqlar

6.1. $x^3 - 4x^2 + 7x - 28 = 0$ va $2x + 9 = 6x - 7$ tenglamalar bir xil *ratsional* ildizlarga ega ekanini isbot qiling.

6.2. Tenglamaning aniqlanish sohasi X ni toping va uni yeching:

a) $x^2 + 4x + 5 = 1 - \frac{1}{x^3 - x} + \frac{1}{2(x+1)} + \frac{1}{2(x-1)} - \frac{1}{x}$;

b) $x^2 + 4a^2x^2 - 12a^4 + \frac{9a^4}{x^2 - 2a^2} = 0$.

2. Bir o'zgaruvchili tenglamalarni yechishning ayrim usullari.

Biz maktab matematika kursidan ayrim sodda tenglamalarni, jumladan, kvadrat tenglamani yechishni bilamiz. Bu o'rinda

umumiy holda keng qo'llaniladigan ko'paytuvchilarga ajratish va yangi o'zgaruvchi kiritish usullarini bayon qilamiz.

T e o r e m a. $P(x) = P_1(x) \cdot \dots \cdot P_n(x)$ va $P_k(x)$, $1 \leq k \leq n$, X to'plamda aniqlangan bo'lsin. U holda $P(x) = 0$ tenglamaning har qanday $x \in X$ ildizi $P_k(x) = 0$, $1 \leq k \leq n$ tenglamalardan aqalli birining ildizi bo'ladi (va aksincha).

I s b o t. $\alpha \in X$ soni $P(x) = 0$ tenglamaning ildizlaridan biri bo'lsin. $P(\alpha) = 0$ yoki $P_1(\alpha) \cdot \dots \cdot P_n(\alpha) = 0$ (1).

Ko'paytma nolga teng bo'lishi uchun ko'paytuvchilardan aqalli biri nolga teng bo'lishi, ya'ni α soni $P_k(x) = 0$, $1 \leq k \leq n$, tenglamalardan aqalli birining ildizi bo'lishi kerak. Aksincha, agar α soni $P_k(x) = 0$ tenglamalardan birining ildizi bo'lsa, ya'ni $P_k(x)$ ko'paytuvchilardan birini nolga aylantirsa, (1) dagi ko'paytma nolga aylanadi. Teorema isbotlandi.

1- m i s o l. $P(x) = (3x + 1)(3x - 1)(2x + 5) = 0$ tenglamani yeching.

Y e c h i s h. Berilgan tenglama mos ravishda $x_1 = -\frac{1}{3}$; $x_2 = \frac{1}{3}$; $x_3 = -\frac{5}{2}$ ildizlarga ega bo'lgan $3x + 1 = 0$, $3x - 1 = 0$, $2x + 5 = 0$ tenglamalarga ajraladi. 1- teoreмага ko'ra $\{-\frac{1}{3}; \frac{1}{3}; -\frac{5}{2}\}$ to'plam berilgan tenglamaning yechimi bo'ladi.

2- m i s o l. $x^4 - 9x^2 + 20 = 0$ tenglamani yeching.

Bu *bikvadrat tenglama* deb ataluvchi $ax^4 - bx^2 + c = 0$ ($a \neq 0$) tenglamaning xususiy holidir. Bunday ko'rinishdagi tenglamalarni yechish uchun $x^2 = y$ almashtirishni bajarish kerak. Bu almashtirish berilgan tenglamani $y^2 - 9y + 20 = 0$ kvadrat tenglamaga olib keladi. Biz berilgan tenglamani ko'paytuvchilarga ajratish usuli bilan yechamiz.

Y e c h i s h. Tenglamaning chap qismini ko'paytuvchilarga ajratamiz:

$$x^4 - 9x^2 + 20 = (x^4 - 4x^2) - (5x^2 - 20) = x^2(x^2 - 4) - 5(x^2 - 4) = (x^2 - 4)(x^2 - 5) = (x - 2)(x + 2)(x - \sqrt{5})(x + \sqrt{5}) = 0.$$

Endi $x - 2 = 0$, $x + 2 = 0$, $x - \sqrt{5} = 0$, $x + \sqrt{5} = 0$ tenglamalarini yechib, berilgan tenglama yechimlarini topamiz:

$$\{-2; 2; -\sqrt{5}; \sqrt{5}\}.$$

3- m i s o l. $x^4 - 4x^3 - 10x^2 + 37x - 14 = 0$ tenglamani yeching.

Y e c h i s h. Tenglamaning chap tomonida 4- darajali ko'phad turibdi. Uni kvadrat uchhadlar ko'paytmasi shaklida tasvirlashga harakat qilamiz:

$$x^4 - 4x^3 - 10x^2 + 37x - 14 = (x^2 + px + q)(x^2 + bx + c).$$

Chap va o'ng tomonlarda turgan ko'phadlarning mos koeffitsiyentlarini tenglashtiramiz:

$$\begin{cases} p + b = -4, \\ c + q + pb = -10, \\ pc + qb = 37, \\ qc = -14. \end{cases}$$

Bu sistemaning biror butun qiymatli yechimini topamiz. $qc = -14$ dan q va c lar 14 ning bo'luvchilari ekanini ko'rish qiyin emas. Demak, ular uchun ± 1 , ± 2 , ± 7 , ± 14 larni sinab ko'rish kerak.

Agar $q = 1$ bo'lsa, $c = -14$ bo'ladi. Ikkinchi va uchinchi tenglamalar $\begin{cases} pb = 3, \\ -14p + b = 37 \end{cases}$ sistemani beradi. Bu sistemadan b

uchun $b^2 - 37b - 42 = 0$ tenglama hosil bo'ladi. Bu tenglama esa yechimga ega emas.

Shuning uchun, $q = 1$ da sistema butun yechimga ega emas.

Agar $q = 2$ bo'lsa, $c = -7$ ga ega bo'lamiz. Bu holda sistemani $q = 2$, $c = -7$, $b = 1$, $p = -5$ lardan tuzilgan butun yechimga ega bo'ladi (tekshirib ko'ring).

Shunday qilib,

$$x^4 - 4x^3 - 10x^2 + 37x - 14 = (x^2 - 5x + 2)(x^2 + x - 7).$$

Demak, berilgan tenglama $x^2 - 5x + 2 = 0$ va $x^2 + x - 7 = 0$ tenglamalarga ajraladi. Bu tenglamalarni yechib, berilgan tenglamaning ham yechimlari bo'ladigan $\frac{5 \pm \sqrt{17}}{2}$, $\frac{-1 \pm \sqrt{29}}{2}$ sonlarni topamiz.

4- m i s o l. $(x^2 + x + 4)^2 + 3x(x^2 + x + 4) + 2x^2 = 0$ tenglamani yeching.

Y e c h i s h. Chap tomonni $y = x^2 + x + 4$ ga nisbatan kvadrat uchhad sifatida qarab, ko'paytuvchilarga ajratamiz:

$$y^2 + 3xy + 2x^2 = (y + x)(y + 2x).$$

Bundan $(x^2 + 2x + 4)(x^2 + 3x + 4) = 0$ tenglama hosil bo'ladi. Oxirgi tenglama yechimga ega emas. Demak, berilgan tenglama ham yechimga ega emas.

5 - m i s o l. $(x^2 - 3x + 1)(x^2 + 3x + 2)(x^2 - 9x + 20) = -30$ tenglamani yeching.

Y e c h i s h. $(x^2 + 3x + 2)(x^2 - 9x + 20) = (x + 1)(x + 2) \times (x - 4)(x - 5) = [(x + 1)(x - 4)] \cdot [(x + 2)(x - 5)] = (x^2 - 3x - 4) \times (x^2 - 3x - 10)$ bo'lgani uchun berilgan tenglamani quyidagicha yozib olish mumkin:

$$(x^2 - 3x + 1)(x^2 - 3x - 4)(x^2 - 3x - 10) = -30.$$

Bu tenglamada $y = x^2 - 3x$ almashtirish orqali yangi o'zgaruvchi y ni kiritamiz:

$$(y + 1)(y - 4)(y - 10) = -30.$$

Bu tenglamadan $y_1 = 5, y_2 = 4 + \sqrt{30}, y_3 = 4 - \sqrt{30}$ larni topib, quyidagi uchta kvadrat tenglamaga ega bo'lamiz:

$$x^2 - 3x = 5; \quad x^2 - 3x = 4 + \sqrt{30}; \quad x^2 - 3x = 4 - \sqrt{30}.$$

Bu tenglamalarni yechsak, berilgan tenglamaning barcha ildizlari hosil bo'ladi:

$$\frac{3 \pm \sqrt{29}}{2}; \quad \frac{3 \pm \sqrt{25 + 4\sqrt{30}}}{2}; \quad \frac{3 \pm \sqrt{25 - 4\sqrt{30}}}{2},$$

6- m i s o l. $x^4 - 2\sqrt{2}x^2 - x + 2 - \sqrt{2} = 0$ tenglamani yeching.

Y e c h i s h. $\sqrt{2} = a$ deb, $x^4 - 2ax^2 - x + a^2 - a = 0$ tenglamani hosil qilamiz. Bu tenglamani a ga nisbatan kvadrat tenglama sifatida qarab, uning $a = x^2 - x, a = x^2 + x + 1$ ildizlarini topamiz. $a = \sqrt{2}$ bo'lgani uchun quyidagi tenglamalarga ega bo'lamiz:

$$x^2 - x = \sqrt{2}; \quad x^2 + x + 1 = \sqrt{2}.$$

Bu tenglamalar berilgan tenglamaning barcha ildizlarini aniqlash imkonini beradi:

$$x_{1,2} = \frac{1 \pm \sqrt{1 + 4\sqrt{2}}}{2}; \quad x_{3,4} = \frac{-1 \pm \sqrt{4\sqrt{2} - 3}}{2}.$$

7- m i s o l. $\frac{4x}{x^2 + x + 3} + \frac{5x}{x^2 - 5x + 3} = -\frac{3}{2}$ tenglamani yeching.

Y e c h i s h. $x = 0$ soni tenglamaning yechimi emas. Shu sababli berilgan tenglama quyidagi tenglamaga teng kuchli:

$$\frac{4}{x + \frac{3}{x} + 1} + \frac{5}{x + \frac{3}{x} - 5} = -\frac{3}{2}.$$

$y = x + \frac{3}{x}$ almashtirish olsak, $\frac{4}{y+1} + \frac{5}{y-5} = -\frac{3}{2}$ tenglama hosil bo'ladi. Bu tenglama $y_1 = -5, y_2 = 3$ ildizlarga ega bo'lgani uchun berilgan tenglama $x + \frac{3}{x} = -5, x + \frac{3}{x} = 3$ tenglamalar majmuasiga

teng kuchli. Ularni yechib, berilgan tenglamaning ildizlarini topamiz:

$$x_{1,2} = \frac{-5 \pm \sqrt{13}}{2}.$$

Yechilgan bu tenglama $\frac{Ax}{ax^2 + b_1x + c} + \frac{Bx}{ax^2 + b_2x + c} = D$ ko'rinishdagi tenglamaning xususiy holidir. Bunday ko'rinishdagi barcha tenglamalar, shuningdek,

$$\frac{ax^2 + b_1x + c}{ax^2 + b_2x + c} \pm \frac{ax^2 + b_3x + c}{ax^2 + b_4x + c} = A$$

va

$$\frac{ax^2 + b_1x + c}{ax^2 + b_2x + c} = \frac{Ax}{ax^2 + b_3x + c}, A \neq 0$$

ko'rinishdagi (bu yerda $ac \neq 0$) tenglamalar ham 7- misol kabi yechiladi.

Chetki hadlaridan bir xil uzoqlikdagi hadlar koeffitsiyentlari teng $ax^4 + bx^3 + cx^3 + bx + a = 0$ ($a \neq 0$) ko'rinishdagi tenglama to'rtinchi darajali *qaytma tenglama* deyiladi. Bunday tenglamalarni yechish uchun uning ikkala qismini x^2 ga bo'lib, $x + \frac{1}{x} = z$

almashtirishni bajaramiz: $a\left(x^2 + \frac{1}{x^2}\right) + b\left(x + \frac{1}{x}\right) + c = 0$, bunda

$z^2 = \left(x + \frac{1}{x}\right)^2 = x^2 + 2 + \frac{1}{x^2}$ bo'lganidan, $a(z^2 - 2) + bz + c = 0$ tenglama hosil bo'ladi. Bu tenglamaning ikkala ildizi bo'yicha $x + \frac{1}{x} = z_1$, $x + \frac{1}{x} = z_2$ tenglamalar tuzilib, bu tenglamalar yechiladi.

8- m i s o l. $5x^4 - 3x^3 - 4x^2 - 3x + 5 = 0$ tenglamani yeching.

Y e c h i s h. Tenglamani ikkala qismini x^2 ga bo'lamiz, so'ng $z = x + \frac{1}{x}$ va $z^2 - 2 = x^2 + \frac{1}{x^2}$ o'rniga qo'yishlarni bajaramiz. $5z^2 - 3z - 14 = 0$ tenglama hosil bo'ladi. Uning yechimi: $\{-1,4; 2\}$. $x + \frac{1}{x} = -1,4$ tenglama $x^2 + 1,4x + 1 = 0$ ko'rinishga keladi. Tenglama diskriminanti manfiy, demak, haqiqiy sonlar sohasida yechim mavjud emas. $x + \frac{1}{x} = 2$ tenglama esa $x^2 - 2x + 1 = 0$ yoki $(x - 1)^2 = 0$ ko'rinishga keladi. Bu tenglama ikki karrali $x = 1$ ildizga ega. Berilgan tenglamani yechimi: 1.

9- m i s o l. $(x^2 + 27)^2 - 5(x^2 + 27)(x^2 + 3) + 6(x^2 + 3)^2 = 0$ tenglamani yeching.

Y e c h i s h. $\frac{(x^2 + 27)^2}{(x^2 + 3)^2} - 5 \cdot \frac{x^2 + 27}{x^2 + 3} + 6 = 0$. $y = \frac{x^2 + 27}{x^2 + 3}$ deb olsak,

$y^2 - 5y + 6 = 0$ tenglama hosil bo'ladi. $y_1 = 2$, $y_2 = 3$ larga egamiz.

$\frac{x^2 + 27}{x^2 + 3} = 2$, $\frac{x^2 + 27}{x^2 + 3} = 3$ tenglamalar mos ravishda $\pm \sqrt{21}$ va ± 3 ildizlarga ega.

10- m i s o l. $f(f(x)) = x$ ko'rinishidagi tenglamani yechamiz.

$$(x^2 - 4x + 6)^2 - 4(x^2 - 4x + 6) + 6 = x. \quad (*)$$

Y e c h i s h. $x^2 - 4x + 6 = x$ tenglama $x_1 = 2$, $x_2 = 3$ ildizlarga ega bo'lgani uchun $(x^2 - 4x + 6)^2 - 4(x^2 - 4x + 6) + 6$ ko'phad $(x - 2)(x - 3)$ ga qoldiqsiz bo'linadi. Bo'lishni bajarib, $x^2 - 3x + 3$ bo'linmani topamiz. (*) ni $(x^2 - 3x + 3)(x - 2)(x - 3) = 0$ ko'rinishda yozish mumkin. Bu tenglama $x = 2$, $x = 3$ lardan boshqa haqiqiy ildizga ega emas. (*) tenglamani hamma ildizlari: 2; 3.



M a s h q l a r

6.3. Chiziqli tenglamalarni yeching:

a) $3x + 1 = a$;

g) $a + x = a^2x - 1$;

b) $5 + x = ax$;

h) $ax - b = 1 + x$;

d) $4 = ax$;

i) $x = b - a^2x$;

e) $x = a^2x$;

j) $ax - b^2 = 7$;

f) $ax - a^2 = 4 - 2x$;

k) $3 - a^2x = x - b$.

6.4. $m \cdot x = n$ tenglama:

a) faqat bitta ildizga;

b) faqat ikkita har xil ildizga;

d) faqat 1000 ta har xil ildizga;

e) cheksiz ko'p har xil ildizga ega bo'lishi mumkinmi?

6.5. $ax = 1 + b^2$ tenglama cheksiz ko'p har xil ildizlarga ega bo'lishi mumkinmi?

6.6. $(a - 1)x = a^2 - 3a + 2$ tenglama cheksiz ildizga ega bo'lmasligi mumkinmi?

6.7. Ota 45 yoshda, o'g'li 15 yoshda. Necha yildan keyin o'g'li otasidan ikki marta kichik bo'ladi?

6.8. Tenglamani yeching:

a) $3x(x - 1) - 17 = x(1 + 3x) + 1$;

b) $2x - (x + 2) \cdot (x - 2) = 5 - (x - 1)^2$;

d) $\frac{3x+1}{2} = \frac{2x-3}{5}$;

e) $\frac{x-3}{6} + x = \frac{2x-1}{3} - \frac{4-x}{2}$.

6.9. m ning qanday qiymatlarida berilgan tenglamalar R da teng kuchli bo'ladi:

a) $2x + 3 = 12$ va $2x + 3 = 12(3m - \frac{1}{2}) + 15$;

b) $3x + 5 = 12$ va $(3x + 5)(3m - \frac{1}{2}) = 12$;

d) $4 - 3x = 5$ va $-3x + 4 = 3m - 8$;

e) $10x - mx = 1$ va $(10 - m)x = 0$?

6.10. Tenglamani yeching:

a) $(x + 2)(a - 1) + 1 = a^2$;

b) $x = a^2x$;

d) $ax - a^2 = 4 - 2x$;

e) $a + x = a^2x - 1$;

f) $ax - b^2 = 7$;

g) $ax - b = 1 + x$.

6.11. Tenglamani yechimlari to'plamini tuzing:

a) $\frac{3-2x}{15} = \frac{x-2}{3} + \frac{x}{5}$;

b) $\frac{1-3x}{12} = \frac{5x-1}{3} - \frac{7x}{4}$;

d) $\frac{6x-5}{3} - \frac{11}{5} = \frac{4x+3}{5} - 0,6$;

e) $\frac{8x+1}{2} - \frac{9x}{5} = \frac{6x-1}{5} + 0,1$;

f) $\frac{5x-2}{3} = \frac{2x+3}{2} - \frac{x+2}{3}$;

g) $3(x + 8) = 4(7 - x)$;

h) $(x + 3)(x - 6) = (x + 2)(x + 1) + 4$;

i) $(x - 3)(x - 4) = (x - 5)(x - 6) - 7,5$.

6.12. Kvadrat uchhaddan to'la kvadrat ajrating:

a) $2x^2 + 4x - 3$;

f) $x^2 - 6x + 8$;

b) $\frac{1}{3}x^2 - 4x + 16$;

g) $ax^2 - 4a^2x + 4a^3 + 3$;

d) $-5x^2 + 20x - 13$;

h) $6a^2x - 9a^3 - ax^2 + a - 1$;

e) $-0,5x^2 - 0,25x - 2,25$;

i) $x^2 + (a + b)x + ab$.

6.13. x ning barcha qiymatlarida $x^2 + x + 1$ kvadrat uchhad musbat qiymatlar qabul qilishini isbotlang.

6.14. x ning barcha qiymatlarida $-3x^2 + 12x - 13$ kvadrat uchhad manfiy qiymatlar qabul qilishini isbotlang.

6.15. 15 sonini ko'paytmasi 70 ga teng bo'ladigan ikkita sonning yig'indisi ko'rinishida yozish mumkinmi?

- 6.16.** x_1 va x_2 lar $x^2 - 7x + 10 = 0$ tenglamaning ildizlari bo'lsin. Bu ildizlarni topmay, quyidagilarni hisoblang:
- a) $x_1^2 + x_2^2$; f) $\frac{x_1}{x_2} + \frac{x_2}{x_1}$;
- b) $x_1^3 + x_2^3$; g) $x_1 x_2 - \frac{1}{x_1} - \frac{1}{x_2}$;
- d) $\frac{1}{x_1} + \frac{1}{x_2}$; h) $(x_1 x_2)^2 - x_1^3 - x_2^3$;
- e) $\frac{1}{x_1^2} + \frac{1}{x_2^2}$; i) $x_1^2 + x_2^2 + 2x_1 x_2$.
- 6.17.** 6.16 dagi tenglamani $-3x^2 + x + 24 = 0$ tenglama bilan almashtiring va hisoblashlarni bu tenglama uchun bajaring.
- 6.18.** x_1 va x_2 lar $ax^2 + bx + a = 0$ tenglamaning ildizlari bo'lsa, x_1 va x_2 sonlari o'zaro teskari sonlar ekanini isbotlang.
- 6.19.** Berilgan tenglamani yechmay, uning ildizlari ishorasini aniqlang:
- a) $x^2 - 4x + 3 = 0$; g) $6x^2 - x - 1 = 0$;
- b) $x^2 - 6x + 5 = 0$; h) $-20x^2 - 3x + 2 = 0$;
- d) $x^2 - x - 42 = 0$; i) $x^2 - 6x + 10 = 0$;
- e) $x^2 - x - 6 = 0$; j) $-3x^2 + 17 = 0$;
- f) $x^2 + x + 1 = 0$; k) $-5x^2 + x - 7 = 0$.
- 6.20.** Ildizlari:
- a) 2 va -3; d) 2 va 2;
- b) -1 va -5; e) $\frac{1}{3}$ va $\frac{1}{3}$;
- f) $\frac{1}{4}$ va $\frac{1}{6}$; h) 0 va 5;
- g) $-\frac{1}{2}$ va $-\frac{1}{3}$; i) α va β
- bo'lgan kvadrat tenglama tuzing.

- 6.21.** Ildizlari $\frac{5}{7}$ va $-\frac{1}{2}$ bo'lgan shunday kvadrat tenglama tuzingki, uning barcha koeffitsiyentlari butun sonlar bo'lib, ularning yig'indisi 6 ga teng bo'lsin.

6.22. Ildizlari 3 va -2 bo'lgan shunday kvadrat tenglama tuzingki, uning bosh koeffitsiyenti $\frac{1}{2}$ bo'lsin.

Ildizlaridan biri: a) $2 + \sqrt{3}$ ga, b) $3 - \sqrt{2}$ ga, d) $2 - \sqrt{5}$ ga, e) $3 + \sqrt{5}$ ga teng bo'lgan butun koeffitsiyentli keltirilgan kvadrat tenglama tuzing.

Kasr ratsional tenglamalarni yeching:

$$6.23. \frac{5(x-2)}{x+2} - \frac{2(x-3)}{x+3} = 3.$$

$$6.24. \frac{x^2-1}{x} = x^2 - \frac{1}{x}.$$

$$6.25. \frac{y+5}{y^2-5y} - \frac{y-5}{2y^2-10y} = \frac{y+25}{2y^2-50}.$$

$$6.26. \frac{x^2}{x+5} = \frac{25}{x+5}.$$

$$6.27. \frac{3(9x-3)}{9x-6} = 2 + \frac{3x+1}{3x-2}.$$

$$6.28. \frac{3-7x}{2x+4} = \frac{1,5-3,5x}{x+2}.$$

$$6.29. \frac{x+3}{x-3} + \frac{x-3}{x+3} = \frac{10}{3} + \frac{36}{x^2-9}.$$

$$6.30. \frac{1+x}{1-x} = \frac{a}{c}.$$

$$6.31. \frac{3ax-5}{(a-1)(x+3)} + \frac{3a-11}{a-1} = \frac{2x+7}{x+3}.$$

$$6.32. \frac{5+2x}{4x-3} = \frac{3(x+1)}{7-x}.$$

$$6.33. \frac{30}{x^2-1} - \frac{13}{x^2+x+1} - \frac{18x+7}{x^3-1} = 0.$$

$$6.34. \frac{x^2}{x+3} = \frac{x}{x+3}.$$

$$6.35. \frac{x^2-6x}{x-5} = \frac{5}{5-x}.$$

$$6.36. \frac{x^2-6x}{x-5} - \frac{5}{x-5} = 0.$$

$$6.37. \frac{3x+1}{x+2} = 1 + \frac{x-1}{x-2}.$$

$$6.38. \frac{8}{x} = 3x + 2.$$

$$6.39. \frac{4}{9y^2-1} - \frac{4}{3y+1} = \frac{5}{1-3y}.$$

$$6.40. \frac{2x-2}{x+3} - \frac{x-3}{3-x} = 5.$$

$$6.41. \frac{4}{x+3} + 1 = \frac{1}{x-3} + \frac{5}{3-x}.$$

$$6.42. \frac{x^2-4}{x} = \frac{3+2x}{2}.$$

Tenglamalarni ko'paytuvchilarga ajratish usuli bilan yeching:

$$6.43. x^3 - 3x = a^3 + \frac{1}{a^3} (a \neq 0).$$

$$6.44. x^3 - 8x^2 - x + 8 = 0.$$

$$6.45. x^3 - 0,1x = 0,3x^2.$$

$$6.47. y^4 - y^3 - 16y^2 + 16y = 0.$$

$$6.49. x^4 - x^2 = 6x^3 - 6x.$$

$$6.51. 2x^4 - 18x^2 = 5x^3 - 45.$$

$$6.53. x^3 - 3x - 2 = 0.$$

$$6.54. (x^2 + x + 1)(x^2 + x + 2) - 12 = 0.$$

$$6.55. 2(x^2 + 6x + 1)^2 + 5(x^2 + 6x + 1)(x^2 + 1) + 2(x^2 + 1)^2 = 0.$$

$$6.56. (x^2 - x + 1)^4 - 6x^2(x^2 - x + 1)^2 + 5x^4 = 0.$$

$$6.57. \frac{x+6}{x-6} \cdot \left(\frac{x-4}{x+4}\right)^2 + \frac{x-6}{x+6} \cdot \left(\frac{x+9}{x-9}\right)^2 = 2 \cdot \frac{x^2+36}{x^2-36}.$$

$$6.58. x^3 + 7x^2 + 14x + 8 = 0.$$

$$6.59. x^3 - 5x + 4 = 0.$$

$$6.60. x^3 - 8x^2 + 40 = 0.$$

$$6.61. x^3 - 2x - 1 = 0.$$

$$6.62. x^4 - 4x^2 + x + 2 = 0.$$

Tenglamalarni yangi o'zgaruvchi kiritish usuli bilan yeching:

$$6.63. (x^2 - 5x + 4)(x^2 - 5x + 6) = 120.$$

$$6.64. (x^2 + 3)^2 - 11(x^2 + 3) + 28 = 0.$$

$$6.65. t^4 - 2t^2 - 3 = 0.$$

$$6.66. 2x^4 - 9x^2 + 4 = 0.$$

$$6.67. 5y^4 - 5y^2 + 2 = 0.$$

$$6.68. x^4 - 4x^2 + 4 = 0.$$

$$6.69. (x^2 - 2x)^2 - (x - 1)^2 + 1 = 0.$$

$$6.70. (x^2 + 2x)^2 - (x + 1)^2 = 55.$$

$$6.71. (x^2 + x + 1)(x^2 + x + 2) - 12 = 0.$$

$$6.72. (x^2 - 5x + 7) - (x - 2)(x - 3) = 0.$$

$$6.73. (x - 2)(x + 1)(x + 4)(x + 7) = 19.$$

$$6.74. 2x^8 + x^4 - 15 = 0.$$

$$6.75. (2x - 1)^6 + 3(2x - 1)^3 = 10.$$

$$6.46. 9x^3 - 18x^2 - x + 2 = 0.$$

$$6.48. x^3 - x^2 = x - 1.$$

$$6.50. 3x^3 - x^2 + 18x - 6 = 0.$$

$$6.52. 3y^2 - 2y = 2y^3 - 3.$$

$$6.76. (x-2)^6 - 19(x-2)^3 = 216.$$

$$6.77. \frac{x-4}{x+5} + \frac{x+5}{x-4} = 2.$$

$$6.78. \frac{x-4}{x-5} + \frac{6x-30}{x-4} = 5.$$

$$6.79. \frac{x^2+x-5}{x} + \frac{3x}{x^2+x-5} + 4 = 0.$$

$$6.80. x^4 - \frac{50}{2x^4-7} = 14.$$

$$6.81. \frac{1}{x(x+2)} - \frac{1}{(x+1)^2} = \frac{1}{12}.$$

$$6.82. (x^2+2x)^2 - (x+1)^2 = 55.$$

Qaytma tenglamani yeching:

$$6.83. x^4 - 3x^3 + 4x^2 - 3x + 1 = 0.$$

$$6.84. x^4 - 3x^3 + 3x + 1 = 0.$$

$$6.85. x^4 - 4x^3 + x^2 - 4x + 1 = 0.$$

$$6.86. 2x^4 - 4x^3 + 2x^2 - 4x + 2 = 0.$$

$$6.87. x^4 + 2x^3 - x^2 + 2x + 1 = 0.$$

$$6.88. x^4 + 2x^3 + x^2 - 2x + 1 = 0.$$

Qaytma tenglamalarning barcha haqiqiy ildizlarini toping:

$$6.89. x^4 + 5x^3 + 2x^2 + 5x + 1 = 0.$$

$$6.90. 4x^4 + 2x^3 + 3x^2 + x + 1 = 0.$$

$$6.91. 2x^4 + 3x^3 - 13x^2 - 6x + 8 = 0.$$

$$6.92. 3x^4 - 2x^3 + x^2 - 6x + 27 = 0.$$

6.93. Tenglamalarni yeching:

$$a) 8x^3 - 36x^2 + 54x = 0;$$

$$b) 16x^4 + 32x^3 + 12x^2 + 8x - 80 = 0;$$

$$d) x^4 - 8x^3 + 24x^2 - 8x = 65;$$

$$e) (x^2 - 1)^2 + 5(x^4 - 1) - 6(x^2 + 1)^2 = 0;$$

$$f) (x-2)^2 + (x-2)(x+1) + (x+1)^2 = 0;$$

$$g) (x^2 - 3)^2 - 7(x^4 - 9) + 6(x^2 + 3)^2 = 0.$$

6.94. $f(f(x)) = x$ ko'rinishidagi tenglamani yeching:

$$a) (x^2 + 2x - 5)^2 + 2(x^2 + 2x - 5) - 5 = x;$$

$$b) (x^2 - 8x + 18)^2 - 8(x^2 - 8x + 18) + 18 = x;$$

$$d) (x^2 - 3x + 3)^2 - 3(x^2 - 3x + 3) + 3 = x;$$

$$e) (x^2 - x - 3)^2 - (x^2 - x - 3) - 3 = x;$$

$$f) (x^2 - 9x + 16)^2 - 9(9x^2 - 9x + 16) + 16 = x.$$

3. Modul qatnashgan tenglamalar. O'zgaruvchisi modul belgisi ichida qatnashgan tenglama modul qatnashgan tenglama deyiladi.

Masalan, $|x| = 1$, $|3x - 5| = x$, $x^2 + |x - 1| = x$ tenglamalarning har biri modul qatnashgan tenglamadir.

Modul qatnashgan tenglamalarning amaliyotda eng ko'p uchraydigan turlarini qaraymiz:

1) $|f(x)| = g(x)$ ko'rinishdagi tenglama. Modulning ta'rifiga ko'ra o'rinli bo'lgan

$$|f(x)| = \begin{cases} f(x), & \text{agar } f(x) \geq 0 \text{ bo'lsa,} \\ -f(x), & \text{agar } f(x) < 0 \text{ bo'lsa} \end{cases} \quad (1)$$

munosabatdan ko'rinadiki, $|f(x)| = g(x)$ tenglamaning barcha yechimlarini topish uchun $f(x) = g(x)$ tenglamaning $f(x) \geq 0$ tengsizlikni qanoatlantiruvchi barcha yechimlarini va $-f(x) = g(x)$ tenglamaning $f(x) < 0$ tengsizlikni qanoatlantiruvchi barcha yechimlarini topish yetarli, ya'ni

$|f(x)| = g(x)$ tenglama

$$\begin{cases} f(x) = g(x), \\ f(x) \geq 0 \end{cases} \quad (2) \quad \text{va} \quad \begin{cases} -f(x) = g(x), \\ f(x) < 0 \end{cases} \quad (3)$$

sistemalar majmuasiga teng kuchli.

1- misol. $|3x - 2| = x$ tenglamani yechamiz.

Yechish. Bu tenglama uchun (2) va (3) sistemalar mos ravishda quyidagicha bo'ladi:

$$\begin{cases} 3x - 2 = x, \\ 3x - 2 \geq 0 \end{cases} \quad \text{yoki} \quad \begin{cases} -(3x - 2) = x, \\ 3x - 2 < 0. \end{cases}$$

Bu sistemalarni yechib, berilgan tenglamaning barcha yechimlarini olamiz: $x_1 = \frac{1}{2}$; $x_2 = 1$.

(2) sistema $\begin{cases} f(x) = g(x), \\ g(x) \geq 0 \end{cases}$ sistemaga, (3) sistema esa

$\begin{cases} f(x) = -g(x), \\ g(x) > 0 \end{cases}$ sistemaga teng kuchli ekanini ko'rish qiyin emas.

Shu sababli $|f(x)| = g(x)$ tenglama

$$\begin{cases} f(x) = g(x), \\ g(x) \geq 0 \end{cases} \quad (4) \quad \text{va} \quad \begin{cases} f(x) = -g(x) \\ g(x) > 0 \end{cases} \quad (5)$$

sistemalar majmuasiga teng kuchli.

2- misol. $|3x^2 - 2| = x$ tenglamani yechamiz.

Yechish. (4) va (5) sistemalarni tuzamiz:

$$\begin{cases} 3x^2 - 2 = x, \\ x \geq 0 \end{cases} \quad \text{yoki} \quad \begin{cases} 3x^2 - 2 = -x, \\ x > 0. \end{cases}$$

Bu sistemalarni yechib, berilgan tenglamaning barcha yechimlarini hosil qilamiz: $x_1 = \frac{2}{3}$, $x_2 = 1$.

$|f(x)| = g(x)$ tenglamaning ayrim xususiy hollariga to'xtalamiz:

$|f(x)| = a$ tenglama (bu yerda $a \in N$) $a < 0$ da yechimga ega emas; $a \geq 0$ bo'lganda $f(x) = a$ va $f(x) = -a$ tenglamalar majmuasiga teng kuchli;

$|f(x)| = f(x)$ tenglama $f(x) \geq 0$ tengsizlikka teng kuchli;

$|f(x)| = -f(x)$ tenglama $f(x) \leq 0$ tengsizlikka teng kuchli.

3- misol. $|\sqrt{x^2 - 5x - 1}| = -2$ tenglamani yechamiz.

Yechish. $|f(x)| = a$ ko'rinishdagi bu tenglama yechimga ega emas, chunki $a = -2 < 0$.

4- misol. $|3x - 4| = 1$ tenglamani yechamiz.

Yechish. Bu tenglama $|f(x)| = a$ ko'rinishda va $a = 1 \geq 0$. Shu sababli bu tenglamani yechish uchun $3x - 4 = -1$, $3x - 4 = 1$ tenglamalarni yechish kifoya. Ularni yechib, $x_1 = 1$, $x_2 = 1\frac{2}{3}$ larni hosil qilamiz.

5- misol. $|3x - 4| = 3x - 4$ tenglamani yechamiz.

Yechish. $|f(x)| = f(x)$ ko'rinishdagi tenglamaga egamiz. Shu sababli berilgan tenglama $3x - 4 \geq 0$ yoki $x \geq 1\frac{1}{3}$ tengsizlikka teng kuchli. Demak, berilgan tenglamaning barcha yechimlari to'plami $[1\frac{1}{3}; +\infty)$ oraliqdan iborat.

6- misol. $|3x - 4| = 4 - 3x$ tenglamani yechamiz.

Yechish. Bu tenglama $|f(x)| = -f(x)$ ko'rinishda bo'lgani uchun $3x - 4 \leq 0$ yoki $x \leq 1\frac{1}{3}$ tengsizlikka teng kuchli. Demak, berilgan tenglamaning barcha yechimlari $(-\infty; 1\frac{1}{3}]$ oraliqdan iborat;

2) $|f(x)| = |g(x)|$ ko'rinishdagi tenglama.

$a, b \in R$ sonlarini qaraymiz. Agar $a = b$ bo'lsa, $|a| = |b|$ bo'lishi ravshan. Agar $a = -b$ bo'lsa, $|a| = |-b| = |b|$ bo'ladi. Demak, $a = b$ yoki $a = -b$ bo'lsa, $|a| = |b|$ bo'ladi.

Endi $|a| = |b|$ bo'lsin. $b \geq 0$, $b < 0$ hollar bo'lishi mumkin. Agar $b \geq 0$ bo'lsa, $|a| = b$ tenglikka, bundan esa $a = b$ yoki $a = -b$ tenglikka ega bo'lamiz; $b < 0$ bo'lsa, $|b| = -b$ bo'lib, $|a| = -b$

tenglikka, bundan esa $a = -b$ yoki $a = b$ tenglikka ega bo'lamiz. Demak, $|a| = |b|$ bo'lsa, $a = b$ yoki $a = -b$ bo'ladi.

Yuqoridagi mulohazalardan ko'rinadiki, $|a| = |b|$ tenglik $a = b$ yoki $a = -b$ bo'lgan hollarda o'rinli bo'ladi, qolgan hollarda esa o'rinli bo'lmaydi. Bundan foydalanib, quyidagiga ega bo'lamiz:

$|f(x)| = |g(x)|$ tenglama $\begin{cases} f(x) = g(x), \\ f(x) = -g(x) \end{cases}$ majmuasiga teng kuchli

7- misol. $|3x - 4| = |x|$ tenglamani yechamiz.

Yechish. $\begin{cases} 3x - 4 = x, \\ 3x - 4 = -x \end{cases}$ majmuani tuzib, uni yechamiz.

Birinchi tenglama $x = 2$, ikkinchi tenglama $x = 1$ yechimga ega. Demak, 1 va 2 sonlarigina berilgan tenglamaning yechimi bo'ladi.

$|x|^{2n} = |x^{2n}| = x^{2n}$ tenglik ixtiyoriy $n \in R$ sonlari uchun o'rinli bo'lgani sababli, $|f(x)| = |g(x)|$ ko'rinishdagi ayrim tenglamalarni juft darajaga ko'tarish usulida yechish ham mumkin.

8- misol. $|2x - 3| = |x + 1|$ tenglamani yechamiz.

Yechish. Tenglamaning ikkala tomonini kvadratga ko'tarsak, $(2x - 3)^2 = (x + 1)^2$ yoki $4x^2 - 12x + 9 = x^2 + 2x + 1$ tenglama hosil bo'ladi.

Bundan, $x_1 = 4$, $x_2 = \frac{2}{3}$ yechimlarni topamiz;

3) $|f(x) + g(x)| = |f(x)| + |g(x)|$ ko'rinishdagi tenglama. $|a + b| \leq |a| + |b|$ tengsizlikda ($a, b \in R$) tenglik belgisi $ab \geq 0$ bo'lgandagina o'rinli bo'lishini nazarda tutsak, $|f(x) + g(x)| = |f(x)| + |g(x)|$ tenglama $f(x) \cdot g(x) \geq 0$ tengsizlikka teng kuchli ekanini ko'ramiz.

9- misol. $|x^2 - 5x + 1| = x^2 + 5|x| + 1$ tenglamani yechamiz.

Yechish. Berilgan tenglamani quyidagicha yozib olish mumkin: $|(x^2 + 1) + (-5x)| = |x^2 + 1| + |-5x|$. Shu sababli bu tenglama $(x^2 + 1) \cdot (-5x) \geq 0$ tengsizlikka teng kuchli. Tengsizlikni yechib, berilgan tenglamaning barcha yechimlari to'plami $(-\infty; 0]$ ni hosil qilamiz.

Endi modul qatnashgan tenglamalarni yechishda qo'llaniladigan eng samarali usullardan biri – «oraliqlar usuli» ning mohiyatini misol yordamida tushuntiramiz.

10- misol. $|x-1| - 2|x-2| + 3|x-3| = 4$ tenglamani «oraliqlar usuli»da yechamiz.

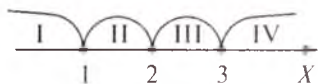

21- rasm.

Yechish. $x-1=0$, $x-2=0$, $x-3=0$ tenglamalarni yechib, $x=1$, $x=2$, $x=3$ sonlarini hosil qilamiz. Bu sonlar sonlar o'qini to'rtta (I, II, III, IV) oraliqqa ajratadi (21-rasm). Berilgan tenglamani shu

oraliqlarning har birida yechamiz.

$x < 1$ bo'lsa, $|x-1|=1-x$, $|x-2|=2-x$, $|x-3|=3-x$ bo'lgani uchun berilgan tenglama $(1-x) - 2(2-x) + 3(3-x) = 4$ ko'rinishni oladi. Bu tenglama $x < 1$ shartni qanoatlantiruvchi yechimga ega emas. Demak, berilgan tenglama $(-\infty; 1)$ oraliqda yechimga ega emas.

$1 \leq x < 2$ bo'lsa, $|x-1|=x-1$, $|x-2|=2-x$, $|x-3|=3-x$ bo'lgani sababli, berilgan tenglama $(x-1) - 2(2-x) + 3(3-x) = 4$ ko'rinishni oladi. Bu tenglama soddalashtirilsa, $0 \cdot x = 0$ tenglama hosil bo'ladi. $0 \cdot x = 0$ tenglamaning $1 \leq x < 2$ tengsizlikni qanoatlantiruvchi barcha yechimlari to'plamini tuzamiz: $[1; 2)$.

$2 \leq x < 3$ bo'lsa, tenglama $x=2$ yechimga, $x \geq 3$ bo'lganda esa tenglama $x=5$ dan iborat yagona yechimga ega ekanligini yuqoridagidek aniqlash mumkin.

Qaralgan to'rtta oraliqlardagi yechimlar to'plamini tuzamiz: $\emptyset \cup [1; 2) \cup \{2\} \cup \{5\} = [1; 2] \cup \{5\}$. Shunday qilib, $[1; 2] \cup \{5\}$

to'plamdagi sonlar va faqat ular berilgan tenglamaning yechimi bo'ladi.



M a s h q l a r

$|f(x)| = a (a \in R)$ ko'rinishdagi tenglamani yeching:

6.95. $|x| = -2.$

6.104. $|3 - x| = -1.$

6.96. $|x| = 2.$

6.105. $|a + x| = -2.$

6.97. $|x| = 0.$

6.106. $|4 - x| = 0.$

6.98. $|x - 1| = -2.$

6.107. $|x^2 - 3x + 1| = 1.$

6.99. $|x - 1| = 2.$

6.108. $|x^3 - x| = 0.$

6.100. $|x - 1| = 0.$

6.109. $|x^4 - x| = 0.$

6.101. $|2x - 5| = -1.$

6.110. $|x^2| = 9.$

6.102. $|2x - 5| = 1.$

6.111. $|x^2 - 1| = 0.$

6.103. $|2x - 5| = 0.$

6.112. $|x - |x|| = 0.$

$|f(x)| = f(x)$ ko'rinishdagi tenglamani yeching:

6.113. $|3x^2 - 7x + 4| = 3x^2 - 7x + 4.$

6.114. $|x^2 - 14x - 15| = x^2 - 14x - 15.$

6.115. $|2 - x - x^2| = 2 - x - x^2.$

6.116. $|3x^2 - 7x + 6| = 3x^2 - 7x + 6.$

$|f(x)| = -f(x)$ ko'rinishdagi tenglamani yeching:

6.117. $|3x^2 - 7x + 6| = 7x - 6 - 3x^2.$

$$6.118. |x^4 - x^2| = x^2 - x^4.$$

$$6.119. |-x^2 - 4x - 4| = x^2 + 4x + 4.$$

$$6.120. |(x-1)^2(x-2)(x-3)| = (x-1)^2(2-x)(x-3).$$

$f(|x|) = g(x)$ ko'rinishdagi tenglamani yeching:

$$6.121. |x| = 3x - 5.$$

$$6.122. x^2 + |x| - 6 = 0.$$

$$6.123. |x| = x^2 - 3x + 5.$$

$$6.124. x + |x| + 5 = x^2.$$

$|f(x)| = g(x)$ ko'rinishdagi tenglamani yeching:

$$6.125. |x + 2| = 2(3 - x).$$

$$6.126. |3x - 2| = 11 - x.$$

$$6.127. 2|x^2 + 2x - 5| = x - 1.$$

$$6.128. |3x + 1| = 5 + 6x.$$

Tenglamani oraliqlar usuli bilan yeching:

$$6.129. |3x - 8| - |3x - 2| = 6.$$

$$6.130. |x - 1| + |x - 3| = 2.$$

$$6.131. |x - 1| + |x - 3| = 3.$$

$$6.132. |x| - |x - 2| = 2.$$

$$6.133. |x - 3| + |x + 2| - |x - 4| = 3.$$

$|f(x) + g(x)| = |f(x)| + |g(x)|$ ko'rinishdagi tenglamani yeching:

$$6.134. |7 - 2x| = |5 - 3x| + |x + 2|.$$

$$6.135. \left| \frac{x^2}{x-1} \right| = \left| \frac{x}{x-1} \right| + |x|.$$

$$6.136. |5x - 4| = |x| + 4|x - 1|.$$

$$6.137. |6x + 13| + |7 - 6x| = 20.$$

$$6.138. |6x| - |6x - 5| = 5.$$

$$6.139. 13 - |-x + 13| = |x|.$$

Ichma-ich modullar qatnashgan tenglamani yeching:

$$6.140. |2 - |1 - |x|| = 1.$$

$$6.141. ||x| - 3| = 3 - |x|.$$

$$6.142. \quad ||6x| - |6x - 3|| = 3.$$

$$6.143. \quad |x - |4 - x|| - 2x = 4.$$

$|f(x)| = |g(x)|$ ko'rinishdagi tenglamani yeching:

$$6.144. \quad |3x - 5| = |5 - 2x|.$$

$$6.145. \quad |x + 1| = |x - 1|.$$

$$6.146. \quad |1 - |2 - x|| = |3 + x|.$$

$$6.147. \quad ||3 - 2x| - 1| = |x - 1|.$$

Parametr qatnashgan tenglamani yeching:

$$6.148. \quad 2|x + a| - |x - 2a| = 3a.$$

$$6.149. \quad a - \frac{2a^2}{|x + a|} = a.$$

$$6.150. \quad |x^2 - a^2| = (x + 3a)^2.$$

$$6.151. \quad x = 2|x - a| - 2|x - 2a|.$$

4. Muhammad al-Xorazmiy – algebra fanining asoschisi.

Ulug' allomalarimizdan biri, algebra fanining asoschisi Abu Abdulloh Muhammad ibn Muso al-Xorazmiy (Xorazm 780 – Bag'dod 847) o'zining «Al-jabr va l-muqobala» kitobida $ax^2 + bx + c = 0$, $ax^2 + c = bx$, $bx + c = ax^2$, $ax^2 = bx$, $ax^2 = c$, $bx = c$ ko'rinishdagi tenglamalarning nomanfiy ildizlarini topishning algebraik usulini ko'rsatgan, uni geometrik tahlil etgan. Masalan, bizdan $6x^2 - 22x - 4 = 4x^2 - 2x - 46$ tenglamani yechish talab etilgan bo'lsin. Dastlab, tenglamani sodda ko'rinishga keltiramiz. Buning uchun:

1) tenglikning bir tomonidan, biror son (ifoda)ni tenglikning ikkinchi tomoniga o'tkazamiz (Al-jabr arabcha so'z bo'lib, o'tkazish, majbur qilish ma'nosini beradi). Son (ifoda) ayrilayotgan bo'lsa, uni tenglikning ikkala tomoniga qo'shamiz. Natijada manfiy ishorali hadlar almashadi:

$$6x^2 - 22x - 4 = 4x^2 - 2x - 46; \quad (+22x, +4, +2x, +46);$$

$$6x^2 + 2x + 46 = 4x^2 + 22x + 4.$$

Hozirgi vaqtda bu amal manfiy ishorali hadni tenglikning ikkinchi tomoniga musbat had qilib o'tkazish deyiladi;

2) *Al-hatt* (qo'yish, ortiqchasini olib tashlash). Bizning misolda tenglikning ikki tomonini 2 ga qisqartiramiz:

$$3x^2 + x + 23 = 2x^2 + 11x + 2;$$

3) *al-muqobala* (muqobil qo'yish, tenglikning bir tomonining ortishi ikkinchi tomonning o'shancha kamayishiga teng kuchli). Shunga ko'ra tenglikning ikkala tomonidan $2x^2$ ni, x ni, 2 ni ayiramiz. Natijada

$$x^2 + 21 = 10x \quad (1)$$

tenglama hosil bo'ladi. (1) tenglamani yechamiz.

I. Yuzi x^2 (yuz birligi) ga teng bo'lgan $ABCD$ kvadrat va yuzi 21 (yuz birligi) ga teng bo'lgan $CDEF$ to'g'ri to'rtburchak yordamida $ABFE$ to'g'ri to'rtburchak yasaymiz (22- rasm).

$ABFE$ to'g'ri to'rtburchakning yuzi $10x$ (yuz birligi) ga (tenglamaning o'ng tomonidagi ifoda) teng. Bu holda AE tomonning uzunligi 10 (uzunlik birligi) ga teng bo'ladi.

II. L nuqta AE tomonning o'rtasi bo'lsin. U holda $AL = LE = 5$. $x \leq AL$ (22- rasm) holni qaraymiz.

Tomoni 5 (uzunlik birligi) ga teng bo'lgan $LNME$ kvadratni va $PF = x$ tomonli $PRMF$ to'g'ri to'rtburchakni yasaymiz. $CK = PK = 5 - x$ bo'lgani uchun $PRMF$ to'g'ri to'rtburchakning yuzi $CDLK$ to'g'ri to'rtburchakning yuziga, $LNME$ kvadratning yuzi esa $DCFE$ to'g'ri to'rtburchak va $KNRP$ kvadrat yuzlarining yig'indisiga teng bo'ladi. Shu sababli $KNRP$ kvadratning yuzi $5^2 - 21 = 4$ (yuz birligi) ga, tomoni esa $KN = \sqrt{4} = 2$ (uzunlik birligi) ga tengdir. $LN = x + KN = 5$ tenglikdan, $x = 3$ ekanligi kelib chiqadi.

$x \geq AL$ holni qarash bilan ikkinchi ildiz $x = 7$ ni ham topish mumkin.

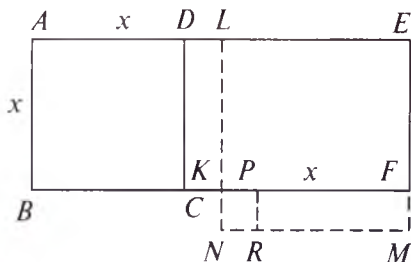

22- rasm.

Agar AE ning uzunligi b ga, $ABFE$ to'g'ri to'rtburchakning yuzi esa c ga teng deb hisoblansa, $x^2 + c = bx$ tenglama ildizi uchun

$$x = \frac{b}{2} + \sqrt{\left(\frac{b}{2}\right)^2 - c}, \text{ ya'ni } x = \frac{b + \sqrt{b^2 - 4c}}{2} \text{ formula hosil bo'ladi.}$$

Al-jabr val-muqobaladan foydalanib, quyidagi tenglamalarni yeching va unga geometrik tahlil bering:

- a) $x^2 + 8 = 16$; b) $x^2 - 5 = 7$; d) $\frac{2}{3} - x^2 = 1$;
 e) $4x^2 = 5$; f) $8x^2 - 6 = 3$; g) $8x^2 - 19 = 10x - 27$.

2- §. Yuqori darajali algebraik tenglamalar

1. Bezu teoremasi. Gerner sxemasi. Ko'phadning ildizlari. (Etyen Bezu (1730 – 1783) – fransuz matematigi). $P(x)$ ko'phadni $x - \alpha$ ikkihadga bo'lganda bo'linmada $Q(x)$, qoldiqda $R(x)$ qolsin:

$$P(x) = (x - \alpha)Q(x) + R(x). \quad (1)$$

Agar bu munosabatga $x = \alpha$ qo'yilsa, $P(\alpha) = 0 \cdot Q(\alpha) + R(\alpha) = R(\alpha) = r$ hosil bo'ladi. Shu tariqa ushbu teorema isbotlanadi:

1-teorema (Bezu). $P(x) = a_0x^n + a_1x^{n-1} + \dots + a_{n-1}x + a_n (a \neq 0)$ ko'phadni $x - \alpha$ ga bo'lishdan chiqadigan r qoldiq shu ko'phadning $x = \alpha$ dagi qiymatiga teng, $r = P(\alpha)$.

Masalan, 1) $x^5 + x + 20$ ni $x + 2$ ga bo'lishdan chiqadigan qoldiq $r = (-2)^5 + (-2) + 20 = -14$; 2) $x^5 + x + 34$ ni $x + 2$ ga bo'lishdan chiqadigan qoldiq $r = (-2)^5 + (-2) + 34 = 0$.

Demak, $x = -2$ soni shu ko'phadning ildizi.

Natijalar. $n \in N$ bo'lganda:

1) $x^n - a^n$ ikkihad $x - a$ ga bo'linadi. Haqiqatan, $P(a) = a^n - a^n = 0$;

2) $x^n + a^n$ ikkihad $x - a$ ga bo'linmaydi. Haqiqatan, $P(a) = a^n + a^n = 2a^n \neq 0$;

3) $x^{2n} - a^{2n}$ ikkihad $x + a$ ga bo'linadi. Haqiqatan, $P(-a) = (-a)^{2n} - a^{2n} = 0$;

4) $x^{2n+1} - a^{2n+1}$ ikkihad $x + a$ ga bo'linmaydi. Haqiqatan,
 $P(-a) = (-a)^{2n+1} - a^{2n+1} = -2a^{2n+1} \neq 0$;

5) $x^{2n+1} + a^{2n+1}$ ikkihad $x + a$ ga bo'linadi. Haqiqatan,
 $P(-a) = (-a)^{2n+1} + a^{2n+1} = 0$;

6) $x^{2n} + a^{2n}$ ikkihad $x + a$ ga bo'linmaydi. Haqiqatan, $P(-a) =$
 $= a^{2n} + a^{2n} = 2a^{2n} \neq 0$.

Bo'lish bajariladigan hollarda bo'linmalarining ko'rinishini aniqlaymiz:

$$x^5 - a^5 = (x - a)(x^4 + ax^3 + a^2x^2 + a^3x + a^4);$$

$$x^5 + a^5 = (x + a)(x^4 - ax^3 + a^2x^2 - a^3x + a^4);$$

$$x^6 - a^6 = (x - a)(x^5 + ax^4 + a^2x^3 + a^3x^2 + a^4x + a^5);$$

$$x^6 + a^6 = (x + a)(x^5 - ax^4 + a^2x^3 - a^3x^2 + a^4x - a^5).$$

Bulardan ko'rinadiki, bo'linma albatta bir jinsli ko'phad bo'lib, x ning darajalari kamayib, a ning darajalarida o'sish tartibida joylashgan va agar bo'luvchi $a + x$ bo'lsa, koeffitsiyentlar $+1$ va -1 almashib keladi, agar bo'luvchi $x - a$ bo'lsa, bo'linmada hosil bo'lgan ko'phadning koeffitsiyentlari 1 ga teng bo'ladi. Bu xulosalarni istagan darajali ko'phadlar uchun umumlashtirish mumkin.

1- m i s o l. $x^5 - ax + 4$ ni $x + 3$ ga bo'lishdagi qoldiq $r = 4$ bo'lsa, a ni toping.

Y e c h i s h. $(-3)^5 - a \cdot (-3) + 4 = 4$, bundan $a = 81$.

$P(x) = a_0x^n + a_1x^{n-1} + a_2x^{n-2} + \dots + a_n$ ko'phadni $x - \alpha$ ikkihadga bo'lishdagi qoldiqni hisoblashning Gorner (Xorner Uilyam (1786–1837) – ingliz matematigi) sxemasi deb ataluvchi usulini ko'rsatamiz.

$$P(x) = Q(x)(x - \alpha) + r$$

bo'lsin. Bunda

$$Q(x) = b_0x^{n-1} + b_1x^{n-2} + b_2x^{n-3} + \dots + b_{n-1}.$$

(1) da x ning bir xil darajalari oldidagi koeffitsiyentlarni tenglashtirib quyidagiga ega bo'lamiz:

$$\begin{aligned}
 a_0 &= b_0 \\
 a_1 &= b_1 - \alpha b_0 \\
 a_2 &= b_2 - \alpha b_1 \\
 &\dots\dots \\
 a_{n-1} &= b_{n-1} - \alpha b_{n-2} \\
 a_n &= r - \alpha b_{n-1}
 \end{aligned}$$

Bundan ko'rinadiki, $b_0 = a_0$, $b_k = \alpha b_{k-1} + a_v$, $k = 1, 2, \dots, n-1$, $r = a_n + \alpha b_{n-1}$.

Bo'linma va qoldiqni hisoblash quyidagi jadval yordamida topiladi.

	a_0	a_1	a_2	...	a_{n-1}	a_n
α		$\alpha b_0 + a_1$	$\alpha b_1 + a_2$...	$\alpha b_{n-2} + a_{n-1}$	$\alpha b_{n-1} + a_n$
	$b_0 = a_0$	b_1	b_2	...	b_{n-1}	r

2- m i s o l. $x^3 + 4x^2 - 3x + 5$ ko'phadni Gerner sxemasidan yordalanib, $x - 1$ ga bo'lishni bajaramiz.

	1	4	-3	5
1	1	5	2	7

Demak, $x^3 + 4x^2 - 3x + 5 = (x - 1)(x^2 + 5x + 2) + 7$.

Bezu teoremasidan $P(x)$ ko'phadni $ax + b$ ko'rinishdagi ikkihadga bo'lishda hosil bo'ladigan r qoldiq $P\left(-\frac{b}{a}\right)$ ga teng bo'lishi kelib chiqadi.

3- m i s o l. $P_3(x) = x^3 - 3x^2 + 5x + 7$ ni $2x + 1$ ga bo'lishdan hosil bo'lgan qoldiqni toping.

Y e c h i s h. Qoldiq $r = P_3\left(-\frac{1}{2}\right) = \left(-\frac{1}{2}\right)^3 - 3 \cdot \left(-\frac{1}{2}\right)^2 + 5 \cdot \left(-\frac{1}{2}\right) + 7 = \frac{29}{8}$ ga teng.

2- t e o r e m a. Agar α soni $P(x)$ ko'phadning ildizi bo'lsa, $P(x)$ ko'phad $x - \alpha$ ikkihadga qoldiqsiz bo'linadi.

I s b o t. Bezu teoremasiga ko'ra, $P(x)$ ni $x - \alpha$ ga bo'lishdan chiqadigan qoldiq $P(\alpha)$ ga teng, shart bo'yicha esa $P(\alpha) = 0$. Isbot bajarildi.

Bu teorema $P(x) = 0$ tenglamani yechish masalasini $P(x)$ ko'phadni chiziqli ko'paytuvchilarga ajratish masalasiga keltirish imkonini beradi.

1- n a t i j a. *Agar $P(x)$ ko'phad har xil $\alpha_1, \dots, \alpha_n$ ildizlarga ega bo'lsa, u $(x - \alpha_1) \dots (x - \alpha_n)$ ko'paytmaga qoldiqsiz bo'linadi.*

2- n a t i j a. *n - darajali ko'phad n tadan ortiq har xil ildizga ega bo'la olmaydi.*

I s b o t. Agar n - darajali $P(x)$ ko'phad $n + 1$ ta har xil $\alpha_1, \dots, \alpha_{k+1}$ ildizlarga ega bo'lganda, u $n + 1$ - darajali $(x - \alpha_1) \dots (x - \alpha_{k+1})$ ko'paytmaga bo'linardi. Lekin bunday bo'lishi mumkin emas.

Yuqorida qaralgan teoremalardan foydalanib, Fransua Viyet (fransuz olimi, 1540 – 1603) tomonidan berilgan hamda $P(x) = 0$ butun algebraik tenglamaning a_i haqiqiy koeffitsiyentlari va α_i ildizlari orasidagi munosabatni ifodalovchi formulalarni keltiramiz:

1) $a_2x^2 + a_1x + a_0 = b(x - \alpha_1)(x - \alpha_2) = bx^2 - b(\alpha_1 + \alpha_2)x + b\alpha_1\alpha_2$. Agar x ning bir xil darajalari oldidagi koeffitsiyentlari tenglashtirilsa, $b = a_2$ bo'ladi. Natijada ushbu formulalar topiladi:

$$\alpha_1 + \alpha_2 = -\frac{a_1}{a_2}, \alpha_1\alpha_2 = \frac{a_0}{a_2};$$

2) shu tartibda $P_3(x) = a_3x^3 + a_2x^2 + a_1x + a_0$ uchun:

$$\alpha_1 + \alpha_2 + \alpha_3 = -\frac{a_2}{a_3}, \alpha_1\alpha_2 + \alpha_1\alpha_3 + \alpha_2\alpha_3 = \frac{a_1}{a_3}, \alpha_1\alpha_2\alpha_3 = -\frac{a_0}{a_3}$$

formulalar topiladi.

Hosil qilingan tengliklarning bajarilishi $\alpha_1, \dots, \alpha_n$ sonlarining $P_n(x) = a_nx^n + \dots + a_0$ ko'phad ildizlari bo'lishi uchun zarur va yetarlidir. Agar $P(x)$ ko'phad $(x - \alpha)^k$ ga qoldiqsiz bo'linsa, lekin

$(x - \alpha)^{k+1}$ ga qoldiqsiz bo'linmasa, α soni $P(x)$ uchun k karrali ildiz bo'ladi.

4- m i s o l. $\alpha_1, \alpha_2, \alpha_3$ lar $x^3 + x^2 + x - 2 = 0$ tenglamaning ildizlari bo'lsin. $\sum_{i=1}^3 \alpha_i^3 = \alpha_1^3 + \alpha_2^3 + \alpha_3^3$ yig'indini topamiz.

Y e c h i s h. Viyet formulalari bo'yicha: $\alpha_1 + \alpha_2 + \alpha_3 = -1$, $\alpha_1\alpha_2 + \alpha_1\alpha_3 + \alpha_2\alpha_3 = 1$. U holda: $(\alpha_1 + \alpha_2 + \alpha_3)^2 = (-1)^2$ bo'yicha $\alpha_1^2 + \alpha_2^2 + \alpha_3^2 = -2(\alpha_1\alpha_2 + \alpha_1\alpha_3 + \alpha_2\alpha_3) + 1 = -2 \cdot 1 + 1 = -1$. Ikkinchi tomondan $\alpha_1, \alpha_2, \alpha_3$ ildiz, ularda ifoda nolga aylanadi:

$$\begin{aligned} \alpha_1^3 + \alpha_1^2 + \alpha_1 - 2 &= 0, \\ \alpha_2^3 + \alpha_2^2 + \alpha_2 - 2 &= 0, \\ \alpha_3^3 + \alpha_3^2 + \alpha_3 - 2 &= 0, \\ \hline \sum \alpha_i^3 + \sum \alpha_i^2 + \sum \alpha_i - 6 &= 0, \end{aligned}$$

bundan $\sum \alpha_i^3 = -(-1) - (-1) + 6 = 8$, bunda qisqa yozish uchun

\sum orqali $\sum_{i=1}^3$ belgilangan.



M a s h q l a r

6.152. $P(x)$ ko'phad $D(x)$ ko'phadga bo'linadimi:

- $P(x) = x^{100} - 3x + 2$, $D(x) = x - 1$;
- $P(x) = x^{100} - 3x + 2$, $D(x) = x + 1$;
- $P(x) = x^{100} - 3x^2 + 2$, $D(x) = x^2 - 1$;
- $P(x) = x^{100} - 3x + 2$, $D(x) = 2x^2 - 1$?

6.153. $x^{2n-1} + a^{2n-1}$ ko'phad $x + a$ ga bo'linishini isbotlang, bunda $a \neq 0$, $n \in \mathbb{N}$.

6.154. $x^n - a^n$ ko'phad $x - a$ ga bo'linishini isbotlang, bunda $a \neq 0$, $n \in \mathbb{N}$.

- 6.155. a) $x^4 - 3x^2 + 1$ ni $x - 2$ ga;
 b) $x^5 - 4x^3 + x^2$ ni $x - 3$ ga;
 d) $x^5 - 4x^3 - x^2 + 1$ ni $2x - 3$ ga;
 e) $x^4 - 3x^3 + x^2 - 1$ ni $3x - 4$ ga bo'lishdagi qoldiqni toping.
- 6.156. m ning qanday qiymatlarida $3x^4 - 2x^3 - m^2x - 2$ ko'phad $x - 2$ ga qoldiqsiz bo'linadi?
- 6.157. m ning qanday qiymatlarida $3x^3 - 4x^2 - mx - 1$ ko'phad $x + 1$ ga bo'linmaydi?
- 6.158. a va b ning qanday qiymatlarida $2x^4 + ax^3 + bx - 2$ ko'phad $x^2 - x - 2$ uchhadga qoldiqsiz bo'linadi?
- 6.159. m va n ning qanday qiymatlarida $x^3 + mx + n$ ko'phad $x^2 + 3x + 10$ uchhadga qoldiqsiz bo'linadi?
- 6.160. $P(x)$ ko'phadni $x - 1$ ga bo'lishda qoldiqda 3, $x - 2$ ga bo'lishda esa qoldiqda 5 hosil bo'ladi. $P(x)$ ni $x^2 - 3x + 2$ bo'lishda hosil bo'ladigan qoldiqni toping.
- 6.161. $P(x)$ ko'phadni $x - a$ ga bo'lishda qoldiqda r_1 , $x - b$ ga bo'lishda esa r_2 hosil bo'ladi ($a \neq b$). $P(x)$ ni $x^2 - (a + b)x + ab$ ga bo'lishda hosil bo'ladigan qoldiqni toping.
- 6.162. Gorner sxemasi yordamida $P(x)$ ko'phadni $D(x)$ ikkihadga qoldikli bo'ling:
- a) $P(x) = x^2 - 5x - 7$, $D(x) = x - 1$;
 b) $P(x) = x^3 - 3x^2 + 5x - 6$, $D(x) = x - 2$;
 d) $P(x) = 2x^4 - 3x^2 - 5x + 2$, $D(x) = x + 1$;
 e) $P(x) = 3x^5 - 4x^3 - x + 1$, $D(x) = x + 3$;
 f) $P(x) = 3x^6 - 4x^5 - x^4 + x^3 - x^2 - 1$. $D(x) = x - 3$;
 g) $P(x) = x^5 - x^2 - 5x - 6$, $D(x) = x - 2$;
 h) $P(x) = x^4 - x^3 + 2x^2 - 5x - 42$, $D(x) = x + 2$;
 i) $P(x) = x^5 - 4x^2 + 5x - 3$, $D(x) = x - 3$;
 j) $P(x) = x^4 - 3x^3 + 2x^2 - 4x - 1$, $D(x) = x + 4$;

- k) $P(x) = x^5 - 4x^3 - 3x^2 + 1$, $D(x) = x - 4$;
 l) $P(x) = x^6 - 5x^4 + 3x^2 - 5x + 6$, $D(x) = x + 2$;
 m) $P(x) = x^5 - 4x^3 + 2x^2 - 3$, $D(x) = x - 1$.

6.163. Gorner sxemasidan foydalanib, $f(x)$ ko'phadning $x = a$ nuqtadagi qiymatini toping:

- a) $f(x) = x^3 - x^2 + 2$, $a = 1$;
 b) $f(x) = x^4 - 3x^3 - x + 10$, $a = 2$;
 d) $f(x) = x^5 - x^4 + 3x^2 - x + 1$, $a = -1$;
 e) $f(x) = x^6 - 7x^3 + 3x^2 - 3$, $a = 3$;
 f) $f(x) = x^6 - 5x^3 - 4x^2 + 8$, $a = 4$;
 g) $f(x) = x^8 + 7x^7 + x^6 + 3x^5 + 3x^4 + 2x^3 + x^2 - x + 1$, $a = 5$.

6.164. Gorner sxemasidan foydalanib, $a^3 + b^3 + c^3 - 3abc$ ni ko'paytuvchilarga ajrating.

2. Algebraik tenglamalarning kompleks ildizlari. Algebraning asosiy teoremasi (Gauss teoremasi):

n -darajali (bu yerda $n \geq 1$) har qanday ko'phad aqalli bitta kompleks ildizga ega.

Bu teorema oliy matematika kursida isbotlanadi.

T e o r e m a. *Agar $z = \alpha + \beta i$ kompleks soni haqiqiy koeffitsiyentli $P(z)$ ko'phadning ildizi bo'lsa, $z = \alpha - \beta i$ kompleks soni ham $P(z)$ ko'phadning ildizi bo'ladi.*

I s b o t. z kompleks soni

$$P(z) = a_0 z^n + a_1 z^{n-1} + \dots + a_{n-1} z + a_n$$

ko'phadning ildizi bo'lsin. U holda

$$a_0 z^n + a_1 z^{n-1} + \dots + a_{n-1} z + a_n = 0$$

yoki

$$\overline{a_0 z^n + a_1 z^{n-1} + \dots + a_{n-1} z + a_n} = \bar{0}$$

tenglik o'rinli bo'ladi.

Kompleks songa qo'shma sonni topish amalining xossalaridan foydalansak,

$$a_0(\bar{z})^n + a_1(\bar{z})^{n-1} + \dots + a_{n-1}\bar{z} + a_n = 0$$

tenglikka ega bo'lamiz. Demak, \bar{z} soni ham $P(z)$ ko'phadning ildizi. Teorema isbot bo'ldi.

N a t i j a. *n -darajali $P_n(x)$ ko'phad $x - a$ ko'rinishidagi ikkihadlar va $x^2 + px + q$ ko'rinishidagi manfiy diskriminantli kvadrat uchhadlar darajalarining ko'paytmasidan iborat:*

$P_n(x) = a_0(x - \alpha)^k \dots (x^2 + px + q)^m \dots$, bu yerda $k \in \{0, 1, 2, \dots\}$, $m \in \{0, 1, 2, \dots\}$.



M a s h q l a r

6.165. Tenglamaning barcha kompleks yechimlarini toping:

- | | |
|--------------------------|-----------------------------|
| a) $x^2 - 2x + 2 = 0$; | h) $9x^2 + 6x + 10 = 0$; |
| b) $x^2 - 4x + 5 = 0$; | i) $4x^2 + 4x + 5 = 0$; |
| d) $x^2 + 6x + 13 = 0$; | j) $9x^2 - 12x + 5 = 0$; |
| e) $x^2 + 4x + 13 = 0$; | k) $16z^2 - 32z + 17 = 0$; |
| f) $x^2 + 2x + 17 = 0$; | l) $z^2 + 4z + 7 = 0$; |
| g) $x^2 - 8x + 41 = 0$; | m) $z^2 - 6z + 11 = 0$. |

6.166. Kvadrat uchhadni chiziqli ko'paytuvchilarga ajrating:

- | | |
|----------------------|-------------------------|
| a) $x^2 + 2x + 5$; | d) $4z^2 + 8z + 5$; |
| b) $x^2 - 3x + 10$; | e) $25z^2 + 50z + 26$. |

6.167. Tenglamani kompleks sonlar to'plamida yeching:

- | | |
|----------------------------|----------------------------|
| a) $z^4 + 5z^2 - 36 = 0$; | f) $x^4 + 3x^2 - 18 = 0$; |
| b) $x^4 - 8x^2 - 9 = 0$; | g) $x^4 + 4x^2 - 32 = 0$; |
| d) $y^4 - y^2 - 6 = 0$; | h) $z^4 + z^2 + 1 = 0$; |
| e) $t^4 + 2t^2 - 15 = 0$; | i) $z^6 - 2z^3 + 4 = 0$. |

- 6.168.** Ildizlaridan biri $2 - 3i$ bo'lgan haqiqiy koeffitsiyentli kvadrat tenglama tuzing.
- 6.169.** Ildizlari $2 - 3i$, $2 - i$ bo'lgan haqiqiy koeffitsiyentli to'rtinchi darajali tenglama tuzing.
- 6.170.** Ildizlari 2 , $2 - 3i$, $2 - i$ bo'lgan haqiqiy koeffitsiyentli beshinchi darajali tenglama tuzing.
- 6.171.** $x = 1$ soni $x^{2n} - nx^{n+1} + nx^{n-1} - 1$ ko'phadning necha karrali ildizi ekanini aniqlang.
- 6.172.** Quyidagi ko'phadlarni chiziqli va kvadratlik ko'paytuvchilar ko'paytmasi shaklida tasvirlang:
 a) $x^6 + 27$; b) $x^4 + 16x^2$; d) $x^6 + 64$; e) $x^4 + 7x^2$.

3. Butun koeffitsiyentli tenglamalarning ratsional ildizlarini

topish. Ratsional koeffitsiyentli har qanday $a_n x^n + \dots + a_0 = 0$ tenglama unga teng kuchli butun koeffitsiyentli tenglamaga keltirilishi mumkin. Masalan, $\frac{5}{6}x^3 + \frac{2}{3}x^2 - x + 1 = 0$ tenglamaning ikkala qismi 6 ga ko'paytirilsa, unga teng kuchli butun koeffitsiyentli $5x^3 + 4x^2 - 6x + 6 = 0$ tenglama hosil bo'ladi. Endi butun koeffitsiyentli tenglamalar bilan shug'ullanamiz.

Teorema. $x = \frac{p}{q}$ qisqarmas kasr butun koeffitsiyentli

$$a_n x^n + \dots + a_0 = 0, \quad a_n \neq 0, \quad (1)$$

tenglamaning ildizi bo'lishi uchun p soni a_0 ozod hadning, q esa a_n bosh had koeffitsiyentining bo'luvchisi bo'lishi zarur.

Haqiqatan, $\frac{p}{q}$ soni (1) tenglamaning ildizi bo'lsin:

$a_n \left(\frac{p}{q}\right)^n + a_{n-1} \left(\frac{p}{q}\right)^{n-1} + \dots + a_1 \cdot \frac{p}{q} + a_0 = 0$ yoki tenglikning ikkala qismi q^n ga ko'paytirilsa, $a_n p^n + a_{n-1} p^{n-1} q + \dots + a_1 p q^{n-1} + a_0 q^n = 0$ tenglik hosil bo'ladi. Bundan: $a_0 q^n = -a_n p^n -$

$-a_{n-1}p^{n-1}q - \dots - a_1pq^{n-1} = -p(a_n p^{n-1} + a_{n-1}p^{n-2}q + \dots + a_1q^{n-1})$. Tenglikning o'ng qismi p ga bo'linadi. Demak,

chap qismdagi a_0q^n ham p ga bo'linishi kerak. Lekin, $\frac{p}{q}$ qisqarmas kasr, ya'ni p va q^n lar o'zaro tub. Demak, p soni a_0 ning bo'luvchisi. Shu kabi q soni a_n ning bo'luvchisi ekanini isbot qilinadi.

Agar (1) tenglama *keltirilgan tenglama* bo'lsa, ya'ni bosh had koeffitsiyenti $a_n = 1$ bo'lsa, tenglamaning ratsional ildizlari ozod hadning bo'luvchilari orasidan izlanadi.

1- m i s o l. $2x^3 + x^2 - 4x - 2 = 0$ tenglamaning ratsional ildizlarini toping.

Y e c h i s h. Ozod hadning barcha butun bo'luvchilari: $-2; -1; 1; 2$.

Bosh koeffitsiyentning barcha natural bo'luvchilari: $1; 2$.

Tenglamaning ratsional ildizlarini quyidagi sonlar orasidan izlaymiz:

$$-2; -1; -\frac{1}{2}; \frac{1}{2}; 1; 2.$$

Bu sonlarni berilgan tenglamaga bevosita qo'yib ko'rish bilan, ularning ildiz bo'lish yoki bo'lmasligini aniqlaymiz.

Tekshirish ko'rsatadiki, $-\frac{1}{2}$ soni berilgan tenglamaning ildizi, qolgan sonlar esa ildiz emas.

Shunday qilib, berilgan tenglama faqat bitta ratsional ildizga ega: $x = -\frac{1}{2}$.

J a v o b: $-\frac{1}{2}$.

2- m i s o l. Tenglamaning butun ildizlarini toping: $2x^4 - x^3 + 2x^2 + 3x - 2 = 0$.

Y e c h i s h. Ozod hadning barcha butun bo'luvchilari: $-2; -1; 1; 2$. Tenglamaning barcha butun ildizlarini shu sonlar orasidan izlaymiz.

Bu sonlarning har birini tenglamaga qo'yib ko'rib, ular orasidan faqat -1 soni tenglamaning yechimi ekanini aniqlaymiz.

Demak, berilgan tenglama faqat bitta butun yechimga ega.

J a v o b: $x = -1$.

3- m i s o l. $x^3 + 3x^2 - 1 = 0$ tenglamaning butun ildizlarini toping.

Y e c h i s h. Butun ildizlarini -1 ; 1 sonlari orasidan izlaymiz. Bu sonlarning ikkalasi ham tenglamaning ildizi emasligini ko'rish qiyin emas.

J a v o b: tenglama butun ildizga ega emas.

4- m i s o l. $2x^4 - x^3 + 2x^2 + 3x - 2 = 0 (x \in R)$ tenglamani yeching.

Y e c h i s h. Oldingi misollardan farqli, bu misolda tenglamaning barcha haqiqiy ildizlarini topish talab qilinyapti.

Dastlab, ratsional ildizlarni qaraymiz. Ratsional ildizlar (agar ular mavjud bo'lsa) esa -2 ; -1 ; $-\frac{1}{2}$; $\frac{1}{2}$; 1 ; 2 sonlari orasida bo'ladi. -1 va $\frac{1}{2}$ sonlar ratsional ildizlar ekanligiga ishonch hosil qilish mumkin.

Shuning uchun tenglamaning chap tomonidagi ko'phad $(x+1)(x-\frac{1}{2}) = x^2 + \frac{1}{2}x - \frac{1}{2}$ ga qoldiqsiz bo'linadi. Bo'lishni bajarib,

$$2x^4 - x^3 + 2x^2 + 3x - 2 = \left(x^2 + \frac{1}{2}x - \frac{1}{2}\right) \cdot (2x^2 - 2x + 4)$$

ni hosil qilamiz. Tenglamani quyidagi ko'rinishda yozib olamiz:

$$\left(x^2 + \frac{1}{2}x - \frac{1}{2}\right) \cdot (2x^2 - 2x + 4) = 0.$$

$2x^2 - 2x + 4 = 0$ tenglamaga yangi haqiqiy ildizlarni bermaydi.

J a v o b: $x_1 = -1$; $x_2 = \frac{1}{2}$.

5- m i s o l. $2x^3 - 7x^2 + 5x - 1 = 0$ tenglamaning $\frac{p}{q}$ ratsional ildizlarini topamiz, bunda p va q lar o'zaro tub, $B(p; q) = 1$.

Y e c h i s h. p sonini ozod hadning, q ni esa bosh koeffitsiyentning bo'luvchilari orasidan izlaymiz. Ular ± 1 va ± 2 .

Demak, ratsional ildizlar ± 1 , $\pm \frac{1}{2}$ sonlari ichida bo'lishi mumkin.

Bu sonlarni tenglamaga ketma-ket qo'yib hisoblash, $\frac{1}{2}$ ning ildiz ekanini ko'rsatadi. Tenglamaning qolgan ildizlarini topish uchun uning chap qismini $x - \frac{1}{2}$ ga yoki $2x - 1$ ga bo'lamiz. Bo'linmada:

$x^2 - 3x + 1$ uchhad hosil bo'ladi. Uning ildizlari: $\frac{3 \pm \sqrt{5}}{2}$.

Izlanayotgan yechim: $x_1 = -\frac{1}{2}$, $x_{2,3} = \frac{3 \pm \sqrt{5}}{2}$.



M a s h q l a r

6.173. Tenglamaning ratsional ildizlarini toping:

- $3x^3 - 4x^2 + 5x - 18 = 0$;
- $x^3 - 4x^2 - 27x + 90 = 0$;
- $x^4 - x^3 + x + 2 = 0$;
- $2x^3 - 5x^2 + 8x - 3 = 0$;
- $4x^4 + 8x^3 - 3x^2 - 7x + 3 = 0$;
- $x^4 + x^3 + x^2 + 3x + 2 = 0$;
- $x^4 - 4x^3 - 13x^2 + 28x + 12 = 0$;
- $3x^4 + 4x^2 + 5x - 12 = 0$.

6.174. Tenglamaning butun ildizlarini toping:

- $x^4 + 2x^3 + 4x^2 + 3x - 10 = 0$;
- $x^3 + 7x^2 + 14x + 8 = 0$;
- $x^4 - x^3 + 2x^2 - x + 1 = 0$;
- $x^4 + x^2 + x + 2 = 0$;
- $2x^5 + 6x^4 - 7x^3 - 21x^2 - 4x - 12 = 0$.

6.175. Tenglamaning barcha haqiqiy ildizlarini toping:

- $2x^4 + 3x^3 - 8x^2 - 9x + 6 = 0$;
- $2x^4 - 5x^3 - x^2 + 5x + 2 = 0$;
- $5x^4 - 3x^3 - 4x^2 - 3x + 5 = 0$;
- $4x^4 - 3x^3 - 8x^2 + 3x + 4 = 0$;
- $3x^4 - 4x^3 - 7x^2 + 4x + 4 = 0$;
- $2x^4 - 7x^3 - 5x^2 + 7x + 3 = 0$.

4. Tenglamalarni taqribiy yechish. $P(x) = a_n x^n + \dots + a_0$ bo'lsin, $P(x) = 0$ (1) tenglamani taqribiy yechish deyilganda uning noma'lum x^* ildizi yotgan $[a; b]$ oraliqni oldindan tayinlangan $\varepsilon = |b - a|$ dan oshmaydigan kattalikda (qisqacha: ε gacha aniqlikda) topish tushuniladi. $[a; b]$ da yotgan ixtiyoriy c nuqta ildizning taqribiy qiymati sifatida olinishi mumkin: $x^* \approx c \pm \varepsilon$. $P(x)$ ko'phad grafigi absissalar o'qini x^* nuqtada kesib o'tishi tufayli unda $P(x^*) = 0$, nuqtaning ikki tomonida esa ko'phad qarama-qarshi ishoraga ega bo'ladi. Bunga qaraganda agar $P(x)$ ko'phad $[a; b]$ oraliqning chekka nuqtalarida har xil ishoraga ega bo'lsa, ya'ni $P(a)P(b) < 0$ (2) tengsizligi bajarilsa, shu oraliqda (1) tenglama ildizga ega.

Demak, hisoblashlarning 1- qadamida (2) shartdan foydalanib, ildiz yotgan $[a; b]$ oraliq topiladi. Keyingi qadamlarda biror usul qo'llanilib, bu oraliq ketma-ket kichraytiriladi. Agar biror k - qadamda $\varepsilon_k = |b_k - a_k| \leq \varepsilon$ aniqlikka erishilgan bo'lsa, $[a_k; b_k]$ oraliq idagi ixtiyoriy c_k son, masalan, $c_k = (b_k + a_k)/2$ o'rta qiymat ildiz uchun qabul qilinadi va hisoblashlar to'xtatiladi. Tenglamalarni taqribiy yechishning ikkita usuli bilan tanishamiz:

1) *kesmani teng ikkiga bo'lish (dixotomiya) usuli* qo'llanilganda $[a; b]$ oraliq c_1 nuqta bilan $[a; c_1]$, $[c_1; b]$ teng oraliqlarga ajratiladi (23- rasm). Ulardan (2) shart bajariladigani, demak, ildiz mavjud bo'lgani olinadi. Uni $[a_1; b_1]$ orqali belgilaymiz. Uning uzunligi $\varepsilon_1 = |b_1 - a_1| = \frac{|b-a|}{2}$. Agar $\varepsilon_1 \leq \varepsilon$ bo'lsa, masala hal, aks holda $[a_1; b_1]$ oraliq ikkiga bo'linadi va hokazo;

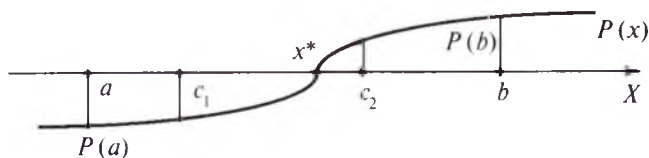

23- rasm.

2) endi *Jamshid ibn Ma'sud G'iyosiddin al-Koshiy* (ko'pincha *G'iyosiddin al-Koshiy nomi bilan mashhur*) (Mirzo Ulug'bek ilmiy maktabi namoyandalaridan biri, Ulug'bekning ustози, Samarqandda ijod etgan, 1430- yilda vafot etgan) ning taqribiy qiymatlarni ildizga *ketma-ket yaqinlashtirishlar (iteratsiya)* usulini keltiramiz. Al-Koshiy $x^3 - kx + m = 0$, $k \neq 0$ ko'rinishdagi tenglamani yechish uchun uni teng kuchli

$$x = \frac{m + x^3}{k} \quad (3)$$

ko'rinishga keltiradi. $\frac{m}{k} = q_1$ (qoldiqda r_1), ya'ni $m = kq_1 + r_1$ bo'lganidan, (3) tenglik

$$x = \frac{kq_1 + r_1 + x^3}{k} \text{ yoki } x = q_1 + \frac{r_1 + x^3}{k} \quad (4)$$

ko'rinishga keladi. 1- yaqinlashish uchun $x_1 = q_1$ qabul qilinadi.

(4) tenglikning o'ng qismiga $x = x_1$ qo'yiladi, $\frac{r_1 + x_1^3}{k} = q_2$ (qoldiqda r_2) bo'yicha $r_1 = kq_2 + r_2 - x_1^3$ topiladi. Natijada:

$$x = q_1 + q_2 + \frac{r_2 + (x^3 - x_1^3)}{k}. \quad (5)$$

Ikkinchi yaqinlashish: $x_2 = q_1 + q_2$ va hokazo. Amalda biz r qoldiqlarni hisoblab o'tirmay, Al-Koshiy usulining ushbu nisbatan sodda modifikatsiyasidan (ko'rinishi o'zgartirilgan rekurrent formuladan) foydalanamiz:

$$q_n = (x_{n-1}^3 - x_{n-2}^3) / k, x_{n+1} = x_n + q_n. \quad (6)$$

Bu formulalar bo'yicha topilgan har qaysi x_n yaqinlashish xatosi (ya'ni uning izlanayotgan ildizdan farqi) $\varepsilon_n < x_n - x_{n-1} = q_n$ bo'ladi va $q_1 > q_2 > \dots > q_n > \dots$ bo'lganidan xato qiymati keyingi qadamlarda kamayib boradi. Hisoblashlarda MK yoki EHM dan foydalanish ma'qul.

Al-Koshiy (modifikatsiyalangan) usuli bilan $x^3 - kx + m = 0$ tenglamani yechish dasturidan fragment (parcha):

```

10 X0 = 0: I = 1          70 IF ABS(Q) <= E THEN
                           GOTO 120
20 K = (kiritilsin)      80 I = I + 1
30 M = (kiritilsin)      90 X2 = X1 + Q
40 E = (aniqlik)         100 X0 = X1: X1 = X2
50 X1 = M/K              10 PRINT, I,X1: GOTO 60
60 Q = (X1^3-X0^3)/K     120 PRINT, I,X1
    
```

Dasturlanadigan MK-56 mikrokalkulator kodida:

x_0 ni Rg0 a , m ni Rga ga, k ni Rgb ga, \div bo'linmani Rgl ga joylashtiramiz. Hisoblashlar ushbu dastur bo'yicha bajariladi:

```

Π → x 1 B ↑ B ↑ × × Π → x 0 B ↑ B ↑ × × - Π → x b ÷ x → Π c Π → 1 + x →
→ Π 2 C / Π Π → x 1 - x → Π 3 F x < 0 2 7 Π → x 2 C / Π C x Π → x 1 x →
Π 0 Π → x 2 x → Π 1 B Π 0 0
    
```

1- misol. $P(x) = x^3 - 6,2x - 5,712 = 0$ tenglamani yeching.

Yechish. $P(-1,5) > 0$, $P(1,5) < 0$, ya'ni $(-1,5; 1,5)$ intervalga nisbatan (2) shart bajarilmoqda, unda ildiz mavjud. (6) formulalardan foydalanaylik.

```

n xn
2 - 1,047414
3 - 1,106628
4 - 1,139872  J a v o b: x ≈ -1,2.
.....
18 - 1,199673
    
```

$f(x) = 0$ tenglamani biror ϵ aniqlikda yechish uchun oddiy iteratsiya usuli qo'llanilganda: a) $f(x) = 0$ tenglama unga teng kuchli bo'lgan $x = \varphi(x)$ ko'rinishga keltiriladi; b) x ning izlanayotgan qiymatiga x_0 boshlang'ich qiymat (yaqinlashish) tanlanadi. Bu qiymat shunday $[a; b]$ oraliqdan olinishi ma'qulki, uning chekka nuqtalarida $f(x)$ funksiya qarama-qarshi ishorali bo'lsin, ya'ni $f(a)f(b) < 0$ shart bajarilsin. Qolgan hisoblashlar $x_{n+1} = \varphi(x_n)$ rekurrent formula bo'yicha ketma-ket takrorlanadi.

1- q a d a m. $x_1 = \varphi(x_0)$ birinchi yaqinlashish topiladi va $\varepsilon_1 = |x_1 - x_0|$ farq hisoblanadi. Agar $\varepsilon_1 < \varepsilon$ bo'lsa, masala hal, hisoblashlar to'xtatiladi va x_1 son ildizning taqribiy qiymati sifatida qabul qilinadi. $\varepsilon_1 > \varepsilon$ bo'lsa, hisoblashlar davom ettiriladi.

2- q a d a m. $x_2 = \varphi(x_1), \varepsilon_2 = |x_2 - x_1|$ va hokazo. Qolgan hisoblashlar ham shu tariqa

$$x_{n+1} = \varphi(x_n), \varepsilon_{n+1} = |x_{n+1} - x_n|, n = 0, 1, 2, \dots \quad (1)$$

förmular bo'yicha bajariladi. Biror k - qadamda $\varepsilon_k \leq \varepsilon$ ro'y bersa, hisoblashlar to'xtatiladi va x_k son x ning ε gacha aniqlikdagi taqribiy qiymati sifatida qabul qilinadi.

Iteratsiya usuli har vaqt ham sonlarning ildizga yaqinlashuvchi ketma-ketligini beravermaydi. Bu masala bilan keyinroq funksiya hosilasini o'rganish jarayonida alohida shug'ullanamiz.

1- m i s o l. $x^4 - 5x^2 + 8x - 8 = 0$ tenglamaning ildizlarini $\varepsilon = 0,001$ aniqlikda topamiz.

Y e c h i s h. EHM $f(1,5) \cdot f(1,8) < 0$ ni ko'rsatadi. Tenglamaning ildizlaridan biri (1,5; 1,8) oraliqda yotishi aniqlandi. Tenglamani $x = \varphi(x)$, bunda $\varphi(x) = (-x^4 + 5x^2 + 8)/8$, rekurrent munosabat ko'rinishida yozamiz. Boshlang'ich yaqinlashish sifatida ildiz yotgan oraliqdan ixtiyoriy bir sonni, masalan, 1,7 ni olamiz, $x_0 = 1,7$. Oraliq hisoblashlar natijalari jadvalga yozib borilishi kerak.

1- q a d a m. $x_1 = \varphi(1,7) = 1,762238, \varepsilon_1 = 0,06... > \varepsilon.$

2- q a d a m. $x_2 = \varphi(x_1) = 1,73424, \varepsilon_2 = 2,68 \cdot 10^{-2} > \varepsilon.$

.....

7- q a d a m. $x_7 = \varphi(x_6) = 1,74430, \varepsilon_7 = 6,51 \cdot 10^{-4} > \varepsilon.$

J a v o b: $x = 1,7443 \pm 6,51 \cdot 10^{-4}.$



M a s h q l a r

6.176. Tenglamalarni oraliqni teng ikkiga bo'lish usulidan foydalanib yeching:

a) $x - \frac{1}{(x+1)^2} = 0, \quad \varepsilon \leq 1 \cdot 10^{-6};$

b) $x - (x+1)^3 = 0, \quad \varepsilon \leq 1 \cdot 10^{-4};$

d) $x^3 - 1,5x^2 + 0,58x - 0,057 = 0, \quad \varepsilon \leq 1 \cdot 10^{-4};$

e) $x^3 + 9x^2 + 11x - 21 = 0.$

6.177. Al-Koshiy usulidan foydalanib quyidagi tenglamalarni yeching:

a) $x^3 - 3x + 1,888 = 0, \quad \varepsilon = 1 \cdot 10^{-5};$

b) $x^3 - 3x + 0,1046719131717587 = 0;$

(Salohiddin Muso ibn Muhammad Qozizoda Rumiy tenglamasi. Qozizoda Rumiy – Mirzo Ulug'bekning ustozlaridan. Samarqandda yashab ijod etgan, 1436- yilda vafot etgan):

d) $x^3 + 5x + 1,9170038 = 0, \quad \varepsilon \leq 0,000001.$

6.178. $f(x) = 0$ tenglamaning ildizlari oraliqni teng ikkiga bo'lish, oddiy iteratsiya va Al-Koshiy usullari qo'llanilib, $\varepsilon = 1 \cdot 10^{-4}$ aniqlikda topilsin (hisoblashlarda EHM dan foydalaning):

a) $x = \frac{x^3 - 5}{7};$

f) $x - (x+1)^3;$

b) $x = x^3 - 1;$

g) $x = 4 + \sqrt{\frac{x-1}{x+1}};$

d) $x = \sqrt[3]{x^2} - 3;$

h) $x^3 - 0,4x + 0,08 = 0;$

e) $x = \frac{x^3 - 4}{9};$

i) $x^4 + 7,18x^3 + 8,2445 = 0.$

6.179. Abu Rayhon Beruniy (973–1048) birlik aylanaga ichki chizilgan muntazam to'qqizburchak tomonining x uzunligi $x^3 = 1 + 3x$ tenglamaning ildizi bo'lishini aniqlang. x ni toping.

3- §. Tengsizliklar

1. Bir o'zgaruvchili tengsizliklar. $A(x) > B(x)$, $A(x) < B(x)$, $A(x) \geq B(x)$, $A(x) \leq B(x)$ munosabatlarga x o'zgaruvchili tengsizliklar deyiladi. x ning tengsizlikni chin sonli tengsizlikka aylantiruvchi har qanday qiymati tengsizlikning *yechimi* deyiladi.

1- misol. 1) $4x - 8 \leq 0$ tengsizlik $x \leq 2$ qiymatlarda bajariladi. Demak, tengsizlikning yechimi: $(-\infty; 2]$;

2) $x^{2\alpha} \geq 0$ ($\alpha \in Z$) tengsizlik x ning har qanday qiymatida bajariladi. Yechim butun son o'qidan iborat;

3) $x^{2\alpha} < 0$ ($\alpha \in Z$) tengsizligi x ning hech bir qiymatida bajarilmaydi: $X = \emptyset$.

$A(x) < B(x)$ tengsizlikdagi $A(x)$ va $B(x)$ ifodalar birgalikda aniqlangan x qiymatlarining X to'plami, ya'ni shu ifodalar mavjudlik sohasining X kesishmasi x o'zgaruvchining $A(x) < B(x)$ tengsizlik uchun *joiz qiymatlari sohasi* deb ataladi. Bunga qaraganda tengsizlikning T yechimi X ning qism-to'plamidan iborat: $T \subset X$.

Endi tengsizliklarni yechish jarayonida bajariladigan ayniy almashtirishlar masalasiga o'tamiz.

1- teorema. *Agar $C(x)$ ifoda barcha $x \in X$ larda aniqlangan bo'lsa, $A(x) < B(x)$ va $A(x) + C(x) < B(x) + C(x)$ tengsizliklar teng kuchlidir.*

2- teorema. *Agar barcha $x \in X$ larda $C(x) > 0$ bo'lsa, $A(x) < B(x)$ va $A(x)C(x) < B(x)C(x)$ tengsizliklar teng kuchli bo'ladi.*

Teoremaning isboti $C(\alpha) > 0$ dan $A(\alpha)C(\alpha) < B(\alpha)C(\alpha)$ ning kelib chiqishiga asoslanadi.

Agar X to'plamda $C(x)$ manfiy bo'lsa, $A(x) < B(x)$ va $A(x)C(x) > B(x)C(x)$ tengsizliklar teng kuchli bo'ladi. Shunga ko'ra, tengsizlikning ikkala qismi X da musbat bo'lgan ifodaga ko'paytirilsa, tengsizlikning ishorasi o'zgarmaydi, X da manfiy bo'lgan ifodaga ko'paytirilsa, tengsizlik ishorasi qarama-qarshisiga o'zgaradi. Tengsizlikning ikkala qismiga x ning ayrim qiymatlarida

sonli qiymatga ega bo'lmaydigan ifoda qo'shilsa yoki ikkala qism shunday ifodaga ko'paytirilsa, yechim yo'qolishi mumkin.

2. Chiziqli tengsizliklar va kvadrat tengsizliklar. $ax > b$ ($ax \geq b$) yoki $ax < b$ ($ax \leq b$) ko'rinishdagi yoki shu ko'rinishga keltirilishi mumkin bo'lgan tengsizlik bir o'zgaruvchili chiziqli tengsizlik deyiladi (bunda x – o'zgaruvchi, $a \neq 0$ va b – o'zgarmas haqiqiy sonlar).

$ax > b$ tengsizlikning har ikki qismi $a \neq 0$ ga bo'linsa, $a > 0$ bo'lganda $x > \frac{b}{a}$, $a < 0$ bo'lganda esa $x < \frac{b}{a}$ bo'ladi. $ax > b$ tengsizlikning yechimi $a > 0$ bo'lganda $(\frac{b}{a}; +\infty)$ oraliqdan, $a < 0$ bo'lganda esa $(-\infty; \frac{b}{a})$ oraliqdan iborat bo'ladi.

1- m i s o l. $5x + 0,7 < 3x - 15,3$ tengsizlikni yeching.

Y e c h i s h. Ayniy almashtirishlar tengsizlikni $2x > -16$ ko'rinishga keltiradi. Tengsizlikning har ikki tomonini 2 ga bo'lamiz: $x > -8$.

J a v o b: $(-8; +\infty)$.

2- m i s o l. $3(x - 2) > x + 2(x - 8)$ tengsizlikni yeching.

Y e c h i s h. Ayniy almashtirishlar tengsizlikni $0 \cdot x > -10$ ko'rinishga keltiradi. Bu tengsizlik barcha $x \in R$ larda o'rinli.

$ax \geq b$, $ax < b$, $ax \leq b$ ko'rinishdagi tengsizliklar ham yuqoridagi mulohazalarga o'xshash mulohazalar yordamida yechiladi.

3- m i s o l. $2(x + 4) < 6x - 4(x - 1)$ tengsizlikni yeching.

Y e c h i s h. Ayniy almashtirishlardan so'ng, $0 \cdot x < -4$ tengsizlik hosil bo'ladi. Bu tengsizlik yechimga ega emas.

$ax^2 + bx + c > 0$ ($ax^2 + bx + c \geq 0$) yoki $ax^2 + bx + c < 0$ ($ax^2 + bx + c \leq 0$) ko'rinishdagi tengsizlik kvadrat tengsizlik deyiladi (bunda x – o'zgaruvchi, $a \neq 0$, b , c – o'zgarmas sonlar).

Kvadrat tengsizliklarni yechishning asosida quyidagi teorema yotadi:

Teorema. $ax^2 + bx + c$ kvadrat uchhadning diskriminanti $D = b^2 - 4ac > 0$ bo'lib, x_1, x_2 ($x_1 < x_2$) lar kvadrat uchhadning ildizlari bo'lsa, $ax^2 + bx + c$ kvadrat uchhad qiymatining ishorasi $x \in (x_1, x_2)$ bo'lganda, a ning ishorasiga qarama-qarshi, $x \notin [x_1, x_2]$ bo'lganda esa a ning ishorasi bilan bir xil bo'ladi. $ax^2 + bx + c$ kvadrat uchhadning diskriminanti $D < 0$ bo'lsa, $\forall x \in R$ uchun kvadrat uchhad qiymatlarining ishorasi a ning ishorasi bilan bir xil bo'ladi.

I s b o t. $D > 0$ bo'lsin. Kvadrat uchhadni chiziqli ko'paytuvchilarga ajratamiz: $ax^2 + bx + c = a(x - x_1)(x - x_2)$.

Agar $x > x_2$ yoki $x < x_1$ bo'lsa, $x - x_1$ va $x - x_2$ ikkihadlar bir xil ishorali bo'lib, ularning ko'paytmasi musbat son bo'ladi. Shu sababli $a(x - x_1)(x - x_2)$ ko'paytmaning va demak, $ax^2 + bx + c$ kvadrat uchhadning ham, ishorasi a ning ishorasi bilan bir xil bo'ladi.

Agar $x \in (x_1, x_2)$ bo'lsa, $x - x_1 > 0$, $x - x_2 < 0$ bo'lgani uchun ularning ko'paytmasi manfiy bo'ladi. Shu sababli $a(x - x_1)(x - x_2)$ ko'paytmaning va demak, $ax^2 + bx + c$ ning ishorasi a ning ishorasiga qarama-qarshi bo'ladi.

$ax^2 + bx + c$ kvadrat uchhadning diskriminanti $D < 0$ bo'lsin.

U holda $ax^2 + bx + c = a \left(\left(x + \frac{b}{2a} \right)^2 + \frac{-D}{4a^2} \right)$ tenglikdan $ax^2 + bx + c$

kvadrat uchhadning ishorasi barcha $x \in R$ lar uchun a ning ishorasi bilan bir xil bo'lishi kelib chiqadi.

4- misol. $x^2 - 5x + 6 > 0$ tengsizlikni yeching.

Y e c h i s h. $D = (-5)^2 - 4 \cdot 1 \cdot 6 > 0$, $a = 1 > 0$, $x_1 = 2$ va $x_2 = 3$ larga egamiz. $x^2 - 5x + 6$ kvadrat uchhad musbat qiymatlar qabul qiladigan barcha $x \in R$ lar qidirilmoqda. Isbotlangan teoreмага ko'ra, $x \notin [2; 3]$ bo'lishi kerak.

J a v o b: $(-\infty; 2) \cup (3; +\infty)$.

5- misol. $x^2 - 4x + 5 > 0$ tengsizlikni yeching.

Yechish. $D = (-4)^2 - 4 \cdot 1 \cdot 5 = -4 < 0$ bo'lgani uchun, isbotlangan teorema ko'ra, barcha $x \in R$ larda $x^2 - 4x + 5$ kvadrat uchhad qiymatining ishorasi a ning ishorasi bilan bir xil bo'ladi. $a = 1 > 0$ ekanidan ko'rinadiki, barcha $x \in R$ lar uchun $x^2 - 4x + 5 > 0$ bo'ladi.

Demak, berilgan tengsizlik barcha $x \in R$ lar uchun o'rinli.

Javob: $(-\infty; +\infty)$.

6- misol. $-x^2 + 4x - 5 > 0$ tengsizlikni yeching.

Yechish. $D = 4^2 - 4 \cdot (-1) \cdot (-5) = -4 < 0$ bo'lgani uchun barcha $x \in R$ larda $-x^2 + 4x - 5 > 0$ ning ishorasi $a = -1$ ning ishorasi bilan bir xil, ya'ni barcha $x \in R$ lar uchun $-x^2 + 4x - 5 < 0$ bo'ladi. Demak, berilgan tengsizlik x ning hech bir qiymatida bajarilmaydi.

Javob: \emptyset .



Mashqlar

Tengsizliklarni yeching:

6.180. $7x - 3(2x + 3) > 2(x - 4)$.

6.181. $\frac{x+1}{4} < 2\frac{1}{2} - \frac{1-2x}{3}$.

6.182. $\frac{6-5x}{5} + \frac{3x-1}{2} > 5 - x$.

6.183. $\frac{7x}{4} < 0,3(x+7) + 2\frac{1}{5}$.

6.184. $-x(x-1) - 6 > 5x - x^2$.

6.185. $7x - 6 < x + 12$.

6.186. $1 - 2x \geq 4 - 5x$.

6.187. $1 - x \geq 2x + 3$.

6.188. $\frac{2}{3-x} < 0$.

6.189. $\frac{4}{2+x} \leq 0$.

6.190. $\frac{x^2}{3x+5} < 0$.

6.191. $3(x-2) + x < 4x + 1$.

6.192. $5(x+1) \geq 2(x-1) + 3x + 3$.

6.193. $\frac{2}{3x+6} < 0$.

6.194. $\frac{5x+3}{2} - 1 \geq 3x - \frac{x-7}{2}$.

6.195. $\frac{3}{2x-4} > 0$.

$$6.196. 2 - \frac{x-4}{3} \leq 2x - \frac{7x-4}{3}. \quad 6.197. \frac{-1,7}{0,5x-2} > 0.$$

$$6.198. (x-1)^2 + 7 > (x+4)^2.$$

$$6.199. (x+1)^2 + 3x^2 > (2x-1)^2 + 7.$$

$$6.200. (x+3)(x-2) \geq (x+2)(x-3).$$

$$6.201. (x+1)(x-2) + 4 \geq (x+2)(x-3) - x.$$

Parametr qatnashgan chiziqli tengsizliklarni yeching:

$$6.202. (a^2+1)y > 3.$$

$$6.203. -(b^2+2)z < 0.$$

$$6.204. ax > -3.$$

$$6.205. ax < b.$$

$$6.206. (a-5)x > 2.$$

$$6.207. ax > b.$$

$$6.208. (2m+1)x > 2n-7.$$

$$6.209. a(x-1) > x-2.$$

$$6.210. (a-1)x > 5a+1.$$

$$6.211. ax > a(a-1).$$

$$6.212. (2b-1)y < 4.$$

$$6.213. (2a+1)x < 3a-2.$$

6.214. y ning qanday qiymatlarida:

a) $\frac{7-2y}{6}$ kasrning qiymati $\frac{3x-7}{12}$ kasrning mos qiymatlaridan katta bo'ladi?

b) $\frac{4,5-2y}{5}$ kasrning qiymati $\frac{2-3y}{10}$ kasrning mos qiymatlaridan kichik bo'ladi?

d) $5y-1$ ikkihadning qiymati $\frac{3y-1}{4}$ kasrning mos qiymatidan katta bo'ladi?

e) $\frac{5-2y}{12}$ kasrning qiymati $1-6y$ ikkihadning mos qiymatlaridan kichik bo'ladi?

6.215. a ning qanday qiymatlarida $(a-1)x^2 - (a+1)x + (a+1) > 0$ tengsizlik x ning barcha haqiqiy qiymatlari uchun bajariladi?

6.216. a ning qanday qiymatlarida $(2-a)x^2 + 2(3-2a)x - 5a+6 \leq 0$ tengsizlik x ning barcha haqiqiy qiymatlari uchun bajariladi?

6.217. a ning $(a-3)x^2 - 2(3a-4) \cdot x + 7a-6 = 0$ tenglama yechimga ega bo'ladigan barcha qiymatlarini toping.

Parametrlri tengsizliklarni yeching:

6.218. $kx^2 - x - 1 > 0$.

6.219. $kx^2 + 12x - 5 < 0$.

6.220. $x^2 + kx + 3 < 0$.

6.221. $x^2 - 2x + k > 0$.

6.222. $kx^2 + kx - 5 < 0$.

6.223. $x^2 > a$.

6.224. $x^2 + (2k + 3)x + k^2 + 4k + 3 < 0$.

6.225. $kx^2 + (2k + 1)x + k + 2 > 0$.

6.226. $(k + 2)x^2 + 2(k + 1)x + k - 1 > 0$.

6.227. $\frac{x^2 + x - 6}{2k + 1} > x + 6(2k - 1)$.

Quyidagi tengsizliklarni grafik usulda yeching:

6.228. $x^2 - 4x + 45 > 0$.

6.229. $x^2 + 2x > 6x - 15$.

6.230. $x^2 - 11x + 30 > 0$.

6.231. $x^2 - 4x + 3 > 0$.

6.232. $3x^2 - 5x - 2 > 0$.

6.233. $5x^2 - 7x + 2 < 0$.

6.234. $3x^2 - 7x - 6 < 0$.

6.235. $3x^2 - 2x + 5 > 0$.

3. Ratsional tengsizliklarni oraliqlar usuli yordamida yechish.

$a_1, a_2, a_3, \dots, a_{n-1}, a_n$ sonlar haqiqiy sonlar va $a_1 < a_2 < a_3 < \dots < a_{n-1} < a_n$ bo'lsin. Quyidagi tengsizlikni qaraymiz:

$$(x - a_1)(x - a_2)(x - a_3) \dots (x - a_{n-1})(x - a_n) > 0. \quad (1)$$

$a_1, a_2, a_3, \dots, a_n$ sonlari son to'g'ri chizig'ini $(-\infty; a_1), (a_1; a_2), (a_2; a_3), \dots, (a_{n-1}; a_n), (a_n; +\infty)$ oraliqlarga ajratadi.

Shu oraliqlardan, *ixtiyoriy* ikkita *qo'shni* oraliqni, masalan, $(a_k; a_{k+1})$ va $(a_{k+1}; a_{k+2})$ oraliqni ajratib olaylik.

(1) tengsizlikning chap tomonidagi ko'paytma bu oraliqlarning biridan ikkinchisiga o'tganda o'z ishorasini o'zgartiradi.

Haqiqatan ham, agar $x \in (a_k; a_{k+1})$ bo'lsa, $x - a_{k+1} < 0$ va agar $x \in (a_{k+1}; a_{k+2})$ bo'lsa, $x - a_{k+1} > 0$ bo'ladi, ya'ni $x - a_{k+1}$ ikkihad $(a_k; a_{k+1})$ va $(a_{k+1}; a_{k+2})$ oraliqlarda har xil ishorali bo'ladi. (1) tengsizlikning chap tomonidagi qolgan ko'paytuvchilar ko'paytmasi bu oraliqlarda bir xil ishoraga ega.

Shu sababli (1) ning chap tomonidagi ko'paytmaning ishorasi bu oraliqlarda har xil bo'ladi. Bu esa (1) tengsizlikni yechishning quyidagi usulini beradi.

(1) tengsizlik $(a_n; +\infty)$ oraliqda o'rinli bo'lgani uchun $(a_{n-1}; a_n)$ oraliqda o'rinli emas; $(a_{n-1}; a_n)$ oraliqda o'rinli bo'lmagani uchun $(a_{n-2}; a_{n-1})$ oraliqda o'rinli va hokazo.

1- m i s o l. $2(2x-5)(3x-8)(5-4x) < 0$ tengsizlikni yeching.

Y e c h i s h. Tengsizlikni $2 \cdot 2 \cdot 3 \cdot (-4) \cdot (x - \frac{5}{2})(x - \frac{8}{3}) \cdot (x - \frac{5}{4}) < 0$ yoki $(x - \frac{5}{2})(x - \frac{8}{3})(x - \frac{5}{4}) > 0$ ko'rinishga keltiramiz. $a_1 = \frac{5}{4}$, $a_2 = \frac{5}{2}$ va $a_3 = \frac{8}{3}$ nuqtalar son o'qini $(-\infty; \frac{5}{4})$, $(\frac{5}{4}; \frac{5}{2})$, $(\frac{5}{2}; \frac{8}{3})$ va $(\frac{8}{3}; +\infty)$ oraliqlarga ajratadi (24- a rasm). Oxirgi tengsizlik $(\frac{8}{3}; +\infty)$, $(\frac{5}{4}; \frac{5}{2})$ oraliqlarda o'rinli.

J a v o b: $(\frac{5}{4}; \frac{5}{2}) \cup (\frac{8}{3}; +\infty)$.

2- m i s o l. $\frac{x^2(x+1)(x-3)}{(x-2)(x-4)} > 0$ tengsizlikni yechamiz.

Y e c h i s h. $x = 2$, $x = 4$ sonlari tengsizlikning yechimi emas. $x \neq 2$, $x \neq 4$ bo'lganda $(x-2)^2 \cdot (x-4)^2 > 0$ bo'ladi. Shu sababli tengsizlikning har ikki tomonini $(x-2)^2 \cdot (x-4)^2$ ga ko'paytirish natijasida berilgan tengsizlikka teng kuchli quyidagi tengsizlik hosil bo'ladi:

$$(x+1)x^2(x-3)(x-2)(x-4) > 0.$$

Oxirgi tengsizlikning chap tomonidagi ifoda $(4; +\infty)$ oraliqda musbat, $(3; 4)$ oraliqda manfiy, $(2; 3)$ oraliqda musbat, $(0; -2)$ oraliqda manfiy qiymatlar qabul qiladi.

$(x-0)^2$ ko'paytuvchi juft daraja bilan qatnashmoqda. Shuning uchun oxirgi tengsizlikning chap tomonidagi ko'paytma $(-1; 0)$

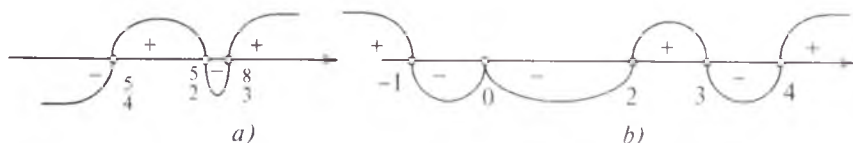

24- rasm.

va $(0; 2)$ oraliqlarning biridan ikkinchisiga o'tishda o'z ishorasini o'zgartirmaydi (24- b rasm), ya'ni bu oraliqlarning ikkalasida ham manfiy qiymatlar qabul qiladi. Oxirgi tengsizlikning chap tomonidagi ifoda $(-\infty; -1)$ oraliqda musbat qiymatlar qabul qiladi.

Berilgan tengsizlikning barcha yechimlari to'plamini aniqlaymiz.

J a v o b: $(-\infty; -1) \cup (2; 3) \cup (4; +\infty)$.



M a s h q l a r

Ratsional tengsizliklarni yeching:

6.236. $(x-2)(x-5)(x-12) > 0$.

6.237. $(x+7)(x+1)(x-4) < 0$.

6.238. $x(x+1)(x+5)(x-8) > 0$.

6.239. $(x+48)(x-37)(x-42) > 0$.

6.240. $(x+0,7)(x-2,8)(x-9,2) < 0$.

6.241. $(x^2-16)(x+17) > 0$.

6.242. $(x-\frac{2}{3})(x^2-121) < 0$.

6.243. $x^3-25x < 0$.

6.244. $x^3-0,01 > 0$.

6.245. $(x^2-9)(x^2-1) > 0$.

6.246. $(x^2-1,5x)(x^2-36) < 0$.

6.247. $(x^2+17)(x-6)(x+2) < 0$.

6.248. $x(2x^2+1)(x-4) > 0$.

6.249. $(x-1)^2(x-24) < 0$.

6.250. $(x+7)(x-4)^2(x-21) > 0$.

6.251. $\frac{x-8}{x+4} > 0$.

6.252. $\frac{x+16}{x-11} < 0$.

6.253. $\frac{x+1}{3-x} \geq 0$.

6.254. $\frac{6-x}{x-4} \leq 0$.

6.255. $(x-1)^2(x-2)^3(x-3)^4(x-4)^5 > 0$.

6.256. $(x-1)^2(x+1)^3(x-2)^4(x-4)^5 \geq 0$.

6.257. $(x+2)^2(x-1)^3(x-2)^7 \leq 0$.

$$6.258. x^3(x+1)^2(x-4)^3 \geq 0.$$

$$6.259. (x-1)^4(x+1)^2 < 0.$$

$$6.260. (x-0,5)(x+0,5)^2(x-2) > 0.$$

$$6.261. x^2(x^2-1)(x+1) \leq 0.$$

$$6.262. \frac{(x-1)(x+2)^4(x-3)^2}{(x-4)^3} > 0.$$

$$6.263. \frac{(x-1)^4(x-2)^3(x+5)}{(x-7)^2} \geq 0.$$

$$6.264. \frac{(x-2)^4(x+2)^3(x-1)}{(x-3)^2} \leq 0.$$

$$6.265. \frac{(x-2)(x-3)^4(x-4)}{x+2} < 0.$$

$$6.266. \frac{(1-x)(x-2)}{12-3x} > 0.$$

$$6.267. (11-x)^3(x-1,5) \geq 0.$$

$$6.268. (2-3x)(4x+5) \leq 0.$$

$$6.269. (2-3x)(4x+5)(3-4x) \geq 0.$$

$$6.270. (3-4x)(5-6x)(x-7) \leq 0.$$

$$6.271. (3-4x)^2(4-7x)^3(x+5) > 0.$$

$$6.272. (13-9x)^3(11-8x)^4(5-x) \leq 0.$$

$$6.273. \frac{(3x-5)(7-4x)^3}{4x+7} > 0.$$

$$6.274. \frac{(4x-7)(3-5x)^2}{(7x-4)^3} < 0.$$

$$6.275. \frac{(4,5x-9)^2}{7x-21} < 0.$$

$$6.276. \frac{0,5}{x-x^2-1} < 0.$$

$$6.277. \frac{x^2-5x+6}{x^2+x+1} < 0.$$

$$6.278. \frac{x^2+2x-3}{x^2+1} < 0.$$

$$6.279. \frac{x^2 + 4x + 4}{2x^2 - x - 1} > 0.$$

$$6.281. x^4 - 2x^2 - 63 \leq 0.$$

$$6.283. \frac{1}{x-1} \leq 2.$$

$$6.285. \frac{5x-6}{x+6} < 1.$$

$$6.287. \frac{x-2}{x^2+1} < -\frac{1}{2}.$$

$$6.289. \frac{x^2 - 7x + 12}{2x^2 + 4x + 5} > 0.$$

$$6.291. \frac{x^2 - 5x + 7}{-2x^2 + 3x + 2} > 0.$$

$$6.293. 2x^2 + \frac{1}{x} > 0.$$

$$6.295. \frac{x^2 - 5x + 6}{x^2 - 11x + 30} < 0.$$

$$6.297. \frac{1}{x+2} < \frac{3}{x-3}.$$

$$6.299. \frac{15-4x}{x^2-x-12} < 4.$$

$$6.301. \frac{(2-x^2)(x-3)^3}{(x+1)(x^2-3x-4)} \geq 0.$$

$$6.303. 2 + \frac{3}{x+1} > \frac{2}{x}.$$

$$6.305. \frac{7}{(x-2)(x-3)} + \frac{9}{x+3} + 1 < 0.$$

$$6.306. (x^2 + 3x + 1)(x^2 + 3x - 3) \geq 5.$$

$$6.307. (x^2 - x - 1)(x^2 - x - 7) < -5.$$

$$6.280. x^4 - 5x^2 + 4 < 0.$$

$$6.282. \frac{3}{x-2} < 1.$$

$$6.284. \frac{4x+3}{2x-5} < 6.$$

$$6.286. \frac{5x-1}{x^2+3} < 1.$$

$$6.288. \frac{x+1}{(x-1)^2} < 1.$$

$$6.290. \frac{x^2+6x-7}{x^2+1} \leq 2.$$

$$6.292. \frac{x+7}{x-5} + \frac{3x+1}{2} \geq 0.$$

$$6.294. \frac{x^2-x-6}{x^2+6x} \geq 0.$$

$$6.296. \frac{x-1}{x+1} < 0.$$

$$6.298. \frac{14x}{x+1} - \frac{9x-30}{x-4} < 0.$$

$$6.300. \frac{1}{x^2-5x+6} \geq \frac{1}{2}.$$

$$6.302. \frac{4}{1+x} + \frac{2}{1-x} < 1.$$

$$6.304. \frac{2(x-3)}{x(x-6)} \leq \frac{1}{x-1}.$$

4. Modul belgisi qatnashgan tengsizliklarni yechish.

1- misol. $|x-2| < 1$ tengsizlikni yeching.

Yechish.

1- *usul.* Tengsizlikning ikkala tomonini kvadratga ko'taramiz: $(x-2)^2 < 1$ yoki $x^2 - 4x + 3 < 0$. Hosil bo'lgan kvadrat tengsizlikning chap tomonini ko'paytuvchilarga ajratib, oraliqlar usulini tatbiq etsak, berilgan tengsizlikning barcha yechimlari to'plami $(1; 3)$ oraliqdan iborat ekanligini ko'ramiz.

2- *usul.* Tengsizlikning chap tomonidagi modul belgisi ostida qatnashgan $x-2$ ikkihad $x=2$ da nolga aylanadi. $x=2$ nuqta son to'g'ri chizig'ini $(-\infty; 2)$ va $(2; +\infty)$ oraliqlarga ajratadi. Bu oraliqlarning har birida $x-2$ ikkihad o'z ishorasini saqlaydi. Berilgan tengsizlikni shu oraliqlarning har birida alohida-alohida yechamiz:

$$\begin{cases} x \geq 2, \\ x-2 < 1; \end{cases} \quad \begin{cases} x < 2, \\ -(x-2) < 1. \end{cases}$$

Birinchi sistemadan $2 \leq x \leq 3$, ikkinchi sistemadan $1 < x < 2$. Bu ikkala yechimlarni birlashtirsak: $(1; 2) \cup [2; 3) = (1; 3)$.

2- misol. $|2x-1| \leq |3x+1|$ tengsizlikni yeching.

Yechish. Tengsizlikning ikkala tomonini kvadratga ko'tarsak: $(2x-1)^2 \leq (3x+1)^2$ yoki $x(x+2) \geq 0$. Bundan $(-\infty; -2] \cup [0; +\infty)$.

3- misol. $|x|+1 \leq 2|x-1|+3x$ tengsizlikni yeching.

Yechish. Modul ishorasi ostida turgan ifodalarni $x=0$ va $x=1$ da nolga aylanadi. Bu nuqtalar son o'qini $(-\infty; 0]$, $[0; 1]$, $[1; +\infty)$ oraliqlarga ajratadi. Ifodalarning bu intervallardagi ishoralari jadvalini tuzamiz:

Ifodalar	$(-\infty; 0)$	$(0; 1)$	$(1; +\infty)$
x	-	+	+
$x-1$	-	-	+

Berilgan tengsizlik birinchi $(-\infty; 0]$ oraliqda $-x + 1 \leq -2(x - 1) + 3x$ ko'rinishga keladi. Ixchamlashtirishlardan so'ng, $-2x \leq 1$ tengsizlik hosil bo'ladi, bundan $-0,5 \leq x \leq 0$ ni topamiz. Ikkinchi intervalda berilgan tengsizlik $x + 1 \leq -2(x - 1) + 3x$ ga yoki ayniy almashtirishlardan so'ng $0 \leq x \leq 1$ ko'rinishga keladi. Bu oraliqda ham tengsizlik bajariladi. Uchinchi intervalda tengsizlik $x + 1 \leq 2(x - 1) + 3x$ yoki $x \geq 0,75$ ko'rinishga keladi. Lekin uchinchi interval $(1; +\infty)$ edi. $[0,75; +\infty) \cap (1; +\infty) = (1; +\infty)$. Topilgan uchta natijani umumlashtirib, berilgan tengsizlikning yechimini yoza-miz: $0,5 \leq x < +\infty$.



Mashqlar

Modul qatnashgan tengsizliklarni yeching:

6.308. $|a| < 1$.

6.310. $|a| > 1$.

6.312. $|a| < 0$.

6.314. $|a| < -3$.

6.316. $|a| \geq -1$.

6.318. $|x - 1| \leq 0$.

6.320. $-3|x - 4| < 0$.

6.322. $3|x - 4| \geq 0$.

6.324. $|x^2 - 1| \leq 0$.

6.326. $|x^3 - 8| > 0$.

6.328. $2|x + 10| > x + 4$.

6.330. $x^2 - 7x + 12 < |x - 4|$.

6.332. $|x^2 + 3x| \geq 2 - x^2$.

6.334. $|x - 2| < 2x - 10$.

6.336. $\left| \frac{x^2 - 3x - 1}{x^2 + x + 1} \right| < 3$.

6.309. $|a| \leq 1$.

6.311. $|a| \geq 1$.

6.313. $|a| \leq 0$.

6.315. $|a| > -1$.

6.317. $|a| \leq -3$.

6.319. $|2x - 3| \leq 0$.

6.321. $3|x - 4| \leq 0$.

6.323. $13|x - 4| > 0$.

6.325. $|x^2 - 1| > 0$.

6.327. $\sqrt{x^2} \leq 1$.

6.329. $3|x - 1| \leq x + 3$.

6.331. $x^2 - 5x + 9 > |x - 6|$.

6.333. $|x^2 - 6x + 8| < 5x - x^2$.

6.335. $|x^2 - x - 3| < 9$.

6.337. $\left| \frac{x^2 - 1}{x} + 12 \right| < 3x - 1$.

6.338. $|2x - 7| \leq 5$.

6.340. $\left| \frac{x+4}{x+2} \right| \leq 1$.

6.342. $|x + 1| + 4 \geq 2|x|$.

6.344. $|x - 2| + |3 - x| \geq 2 + x$.

6.346. $|5 - x| < |x - 2| + |7 - 2x|$.

6.348. $|x^3 - 1| > 1 - x$.

6.350. $\frac{|4-x|}{x+6} < 3$.

6.352. $\left| \frac{x^2 - 5x + 4}{x^2 - 4} \right| \leq 1$.

6.354. $\frac{x^2 - |x| - 6}{x - 2} \geq 2x$.

6.356. $\frac{2x}{|x-3|} \leq |x|$.

6.358. $\frac{|x^2 - 4x| + 3}{x^2 + |x - 5|} \geq 1$.

6.360. $|x - 1| - |x - 2| + |x + 1| > |x + 2| + |x| - 3$.

6.361. $|x - 1| - |x - 2| + |x - 3| \leq 3 + |x - 4| - |x - 5|$.

6.362. $|x + 2| - |x + 1| + |x| \geq \frac{5}{2} + |x - 1| - |x - 2|$.

6.339. $|2x - 1| \leq |x - 1|$.

6.341. $|13 - 2x| \geq |4x - 9|$.

6.343. $|2x + 3| > |x| - 4x - 1$.

6.345. $|x - 1| > |x + 2| - 3$.

6.347. $|x - 6| \leq |x^2 - 5x + 9|$.

6.349. $\frac{2x-5}{|x-3|} > -1$.

6.351. $\frac{|x-2|}{x^2-5x+6} \geq 3$.

6.353. $\left| \frac{x^2 - 3x + 2}{x^2 + 3x + 2} \right| \geq 1$.

6.355. $\frac{4x-1}{|x-1|} \geq |x + 1|$.

6.357. $x^2 \leq \left| 1 - \frac{2}{x^2} \right|$.

6.359. $\frac{|x^2 - 2x| + 4}{x^2 + |x + 2|} \geq 1$.

5. Ayniyatlar va tengsizliklarni isbotlash. Ayniyat va tengsizliklarni isbotlashning umumiy usuli mavjud emas. Ayniyat va tengsizliklarni isbotlashda qo'llaniladigan eng samarali usullardan biri matematik induksiya metodidir.

$A(n) = B(n)$ ayniyatni matematik induksiya metodi yordamida isbotlash uchun dastlab $A(1) = B(1)$ ekaniga ishonch hosil qilish va $A(n+1) - A(n) = B(n+1) - B(n)$ yoki $\frac{A(n+1)}{A(n)} = \frac{B(n+1)}{B(n)}$ ayniyatni isbot qilish yetarli.

1 - misol. Barcha $n \in N$ larda quyidagi ayniyatning o'rinli bo'lishini isbot qiling:

$$\frac{1}{1 \cdot 4} + \frac{1}{4 \cdot 7} + \dots + \frac{1}{(3n-2)(3n+1)} = \frac{n}{3n+1}.$$

Isbot. $A(n) = \frac{1}{1 \cdot 4} + \frac{1}{4 \cdot 7} + \dots + \frac{1}{(3n-2)(3n+1)}$, $B(n) = \frac{n}{3n+1}$ belgilashlarni kiritib, matematik induksiya metodini qo'llaymiz:

$n=1$ da $A(1) = \frac{1}{4}$, $B(1) = \frac{1}{3 \cdot 1 + 1} = \frac{1}{4}$, ya'ni $A(1) = B(1)$ tenglik to'g'ri;

$$A(k+1) = A(k) + \frac{1}{((3k+1)-2)((3k+1)+1)} = A(k) + \frac{1}{(3k+1)(3k+4)} \text{ va}$$

$$B(k+1) = B(k) + \frac{1}{(3k+1)(3k+4)} \text{ munosabatlarga egamiz.}$$

Bu tengliklardan

$$A(k+1) - A(k) = \frac{1}{(3k+1)(3k+4)} = B(k+1) - B(k)$$

ekanini ko'ramiz. Demak, ayniyat barcha $n \in N$ larda to'g'ri.

2 - misol. $\prod_{i=1}^n \left(1 - \frac{1}{(i+1)^2}\right) = \frac{n+2}{2(n+1)}$ ayniyatni isbotlang.

Isbot. Tenglikning chap qismini $A(n)$, o'ng qismini $B(n)$ orqali belgilaylik. U holda, $A(1) = B(1) = \frac{3}{4}$ va $\frac{A(k+1)}{A(k)} = \frac{B(k+1)}{B(k)} = \frac{(k+1)(k+3)}{(k+2)^2}$ tengliklarga ega bo'lamiz.

Demak, barcha $n \in N$ lar uchun $A(n) = B(n)$.

3 - misol. Barcha $x > -1$ va $n \in N$ sonlar uchun $(1+x)^n \geq 1+nx$. (1) *Bernulli tengsizligini* isbot qiling.

Isbot. a) $n=1$ da $1+x \geq 1+x$, ya'ni (1) tengsizlik o'rinli;

b) tengsizlik $n=k$ uchun to'g'ri deb faraz qilaylik: $(1+x)^k \geq 1+kx$;

d) (1) tengsizlik $n=k+1$ uchun ham to'g'ri ekanligini isbotlaymiz: $x+1 > 0$ va $(1+x)^k \geq 1+kx$ tengsizliklarga asosan, $(1+x)^{k+1} = (1+x)^k(1+x) \geq (1+kx)(1+x) = 1+(k+1)x+kx^2 \geq 1+$

+ $(k + 1) \cdot x$ tengsizlikka ega bo'lamiz. Demak, (1) tengsizlik $n = k + 1$ uchun ham to'g'ri.

Matematik induksiya aksiomasiga ko'ra, (1) tengsizlik n ning barcha natural qiymatlarida to'g'ri.

$P(x) \leq Q(x)$ tengsizlikni isbotlashning yana bir usuli, to'g'riligi oldindan ma'lum bo'lgan $P_1(x) \leq Q_1(x)$ tengsizlikda ayniy shakl almashtirishlar bajarib, isbotlanishi kerak bo'lgan $P(x) \leq Q(x)$ tengsizlikni hosil qilishdan iborat.

4 - m i s o l . $x^2 + \frac{1}{x^2} \geq 2$ bo'lishini isbot qiling, bunda $x \neq 0$.

I s b o t . $x^2 + \frac{1}{x^2} - 2 = x^2 + \frac{1}{x^2} - 2x \cdot \frac{1}{x} = \left(x^2 - \frac{1}{x^2}\right)^2$ tenglikka egamiz. Bu tenglikning o'ng tomoni barcha $x \neq 0$ larda nomanfiydir: $\left(x^2 - \frac{1}{x^2}\right)^2 \geq 0$.

Oxirgi tengsizlikda ayniy almashtirishlar (chap tomonidagi qavslarni ochish, o'xshash qo'shiluvchilarni ixchamlash va hokazo) bajarib, $x^2 + \frac{1}{x^2} \geq 2$ tengsizlikni hosil qilamiz. Shu bilan tengsizlik isbotlandi.

5 - m i s o l . Ixtiyoriy $x \geq 0, y \geq 0$ sonlarining o'rta arifmetik qiymati o'rta geometrik qiymatidan kichik emasligini, ya'ni

$\frac{x+y}{2} \geq \sqrt{xy}$ tengsizlik o'rinli ekanini isbot qiling.

I s b o t . Ixtiyoriy $x \geq 0, y \geq 0$ sonlar uchun $(x - y)^2 \geq 0$ tengsizlik bajarilishi ravshan. Bu tengsizlikda shakl almashtirishlar bajaramiz: $(x - y)^2 \geq 0 \Rightarrow x^2 - 2xy + y^2 \geq 0 \Rightarrow x^2 + 2xy + y^2 - 4xy \geq 0 \Rightarrow (x + y)^2 \geq 4xy \Rightarrow \frac{(x+y)^2}{4} \geq xy$.

Oxirgi tengsizlikning ikki tomoni ham nomanfiy son bo'lganligi uchun tengsizlikning har ikki tomonidan kvadrat ildiz chiqarish

mumkin. Ildiz chiqarish natijasida isbotlanishi kerak bo'lgan

$$\frac{x+y}{2} \geq \sqrt{xy} \text{ tengsizlik hosil bo'ladi.}$$

Isbot qilingan bu tengsizlik *Koshi tengsizligi* (Ogyusten Lui Koshi, 1789–1857, fransuz matematigi) deb ataluvchi quyidagi tengsizlikning xususiy holdan iborat:

$$\frac{a_1+a_2+\dots+a_n}{n} \geq \sqrt[n]{a_1 a_2 \dots a_n} . \quad (2)$$

Bu tengsizlik har qanday $a_1 \geq 0, a_2 \geq 0, \dots, a_n \geq 0$ sonlar uchun o'rinli va undagi tenglik ishorasi $a_1 = a_2 = \dots = a_n$ bo'lganda o'rinli bo'ladi.

Bu tengsizlikdan quyidagi ikkita muhim natija kelib chiqadi:

1) yig'indisi o'zgarmas bo'lgan musbat qo'shiluvchilarning ko'paytmasi, bu sonlar o'zaro teng bo'lganda eng katta bo'ladi;

2) ko'paytmasi o'zgarmas bo'lgan musbat ko'paytuvchilarning yig'indisi, bu ko'paytuvchilar o'zaro teng bo'lganda eng kichik bo'ladi.

6 - misol. $y = \frac{x^5+8}{x}$ funksiyaning $(0; +\infty)$ intervaldagi eng kichik qiymatini toping.

Yechish. Funksiyani $y = x^4 + \frac{2}{x} + \frac{2}{x} + \frac{2}{x} + \frac{2}{x}$ elementar qo'shiluvchilar yig'indisi ko'rinishida yozaylik. Bu qo'shiluvchilarning

ko'paytmasi doimiy: $x^4 \cdot \frac{2}{x} \cdot \frac{2}{x} \cdot \frac{2}{x} \cdot \frac{2}{x} = 16$. Shu sababli $x^4 = \frac{2}{x}$ yoki $x = \sqrt[5]{2}$ bo'lganda ularning yig'indisi eng kichik bo'ladi.

Demak, $x = \sqrt[5]{2}$ bo'lganda berilgan funksiya o'zining $(0; +\infty)$

oraligdagi eng kichik qiymati $y(\sqrt[5]{2}) = \frac{(\sqrt[5]{2})^5+8}{\sqrt[5]{2}} = \frac{10 \sqrt[5]{16}}{2} = 5 \sqrt[5]{16}$ ga erishadi.

7 - misol. $y(x) = x^4(27 - x^4)$ funksiyaning eng katta qiymatini toping.

Yechish. Funksiya $x < \sqrt[4]{27}$, $x \neq 0$ bo'lganda musbat qiymatlar qabul qiladi. Shu sababli funksiya o'zining eng katta

qiymatiga x ning $x < \sqrt[4]{27}$, $x \neq 0$ tengsizliklarni qanoatlantiruvchi biror qiymatida erishishi mumkin. x ning $x < \sqrt[4]{27}$, $x \neq 0$ tengsizliklarni qanoatlantiruvchi barcha qiymatlarida funksiya ifodasidagi ko'paytuvchilarning har biri doimiy: $x^4 + (27 - x^4) = 27$. Shu sababli ularning ko'paytmasi $x^4 = (27 - x^4)$ yoki $x = \sqrt[4]{\frac{27}{2}}$

bo'lganda eng katta bo'ladi. Demak, $x = \sqrt[4]{\frac{27}{2}}$ bo'lganda berilgan

funksiya o'zining eng katta qiymati $y = \left(\sqrt[4]{\frac{27}{2}}\right)^2 = \left(\frac{27}{2}\right)^{\frac{1}{2}}$ ni qabul

qiladi. Izlanayotgan eng katta qiymat: $\left(\frac{27}{2}\right)^{\frac{1}{2}}$.

8 - misol. Teng perimetrli uchburchaklar ichida teng tomonli uchburchak eng katta yuzga ega bo'lishini isbot qiling.

Isbot. Perimetri $2p$ ($p = \text{const}$) bo'lgan barcha uchburchaklarni qaraymiz. Bu uchburchaklarning yuzini Geron formulasi $S = \sqrt{p(p-a)(p-b)(p-c)}$ orqali ifodalaymiz, bu yerda a, b, c lar uchburchakning tomonlari.

Ildiz ostidagi ko'paytuvchilar musbat va ularning yig'indisi $(p-a) + (p-b) + (p-c) = 3p - (a+b+c) = p = \text{const}$ bo'lgani uchun, $p(p-a)(p-b)(p-c)$ ko'paytma $p-a = p-b = p-c$ bo'lganda eng katta bo'ladi. Bu yerda $a=b=c$ bo'lganda yuz eng katta bo'lishi kelib chiqadi. Isbot bo'ldi.



Mashqlar

6.363. Ayniyatlarni isbot qiling:

$$a) \frac{1}{1 \cdot 5} + \frac{1}{5 \cdot 9} + \dots + \frac{1}{(4n-3)(4n+1)} = \frac{n}{4n+1};$$

$$b) \frac{1}{1 \cdot 3 \cdot 5} + \frac{1}{3 \cdot 5 \cdot 7} + \dots + \frac{1}{(2n-1)(2n+1)(2n+3)} = \frac{n(n+1)}{2(2n+1)(2n+3)};$$

$$d) \frac{1^2}{1 \cdot 3} + \frac{2^2}{3 \cdot 5} + \dots + \frac{n^2}{(2n-1)(2n+1)} = \frac{n(n+1)}{2(2n+1)};$$

e) $x + 2x^2 + 3x^3 + \dots + nx^n = \frac{x - (n+1)x^{n+1} + nx^{n+2}}{(1-x)^2}$, bunda $x \neq 1$.

6.364. Agar $a > b > 0$ bo'lsa, $a^n > b^n$ bo'lishini isbot qiling.

6.365. Har qanday $n \in N$ da: 1) $2^n > n$; 2) $2^n > 2n + 1$ bo'lishini isbot qiling:

a) $s = 1 + \frac{1}{1} + \frac{1}{1 \cdot 2} + \frac{1}{1 \cdot 2 \cdot 3} + \frac{1}{1 \cdot 2 \cdot 3 \cdot 4} + \dots +$
 $+ \frac{1}{1 \cdot 2 \cdot 3 \cdot 4 \cdot \dots \cdot n} < 2,75, n \in N;$

b) $\left(1 + \frac{1}{n}\right)^n < 3, n \in N;$

d) $(m+1)^m < m^{m+1}, m \geq 3, m \in N;$

e) $99^{66} < 66^{99};$

f) $x^4 + x^2 + 1 \geq \frac{1}{3}(x^2 + x + 1)^2, x \in R;$

g) $a^n + b^n \geq \frac{(a+b)^n}{2^{n-1}}, a > 0, b > 0, n \in N.$

6.366. Tengsizliklarni isbotlang:

a) $\frac{1}{n+1} + \frac{1}{n+2} + \dots + \frac{1}{3n} + \frac{1}{3n+1} > 1;$

b) $\frac{1}{2^2} + \frac{1}{3^2} + \dots + \frac{1}{n^2} < 3, n \in N;$

d) $1 + \frac{1}{\sqrt{2}} + \frac{1}{\sqrt{3}} + \dots + \frac{1}{\sqrt{n}} > 2\sqrt{n};$

e) $1 + \frac{1}{1!} + \frac{1}{2!} + \dots + \frac{1}{n!} < 3\sqrt{n}$, bunda $n! = 1 \cdot 2 \cdot \dots \cdot n$;

f) $\frac{a^6 + b^6}{2} \geq a^3 b^3;$

g) $(1+x)^n > 1 + nx$, bu yerda $1+x > 0, n \in N$;

h) $a^2 + b^2 + c^2 \geq \frac{1}{3}$, bu yerda $a+b+c=1, a, b, c \in R$;

- i) $(a+b)(b+c)(a+c) \geq 8abc$, bu yerda $a, b, c > 0$;
 j) $a^2 + ab + b^2 \geq 0$, bu yerda $a, b \in R$;
 k) $a^3 + b^3 \geq a^2b + ab^2$ ($a, b \in R$);
 l) $(1+a)(1+b)(1+c) \geq 8$ ($a, b, c > 0$);
 m) $(a+b)(b+c)(c+a) \geq 8abc$ ($a, b, c > 0$);
 n) $a+b+c \geq \sqrt{ab+ac+bc}$ ($a, b, c > 0$);
 o) $a^4 + b^4 + c^4 \geq abc(a+b+c)$ ($a, b, c > 0$);
 p) $(\sqrt{a} + \sqrt{b})^8 \geq 64ab(a+b)^2$ ($a, b \geq 0$).

6.367. Ko'rsatilgan oraliqda funksiyaning eng katta qiymatini toping:

- a) $y = 25x^3 - 8x^4$, $0 < x < 5$;
 b) $y = 100x^3 - 3x^4$, $0 < x < 33\frac{1}{3}$;
 d) $y = 4x^3 - x^4$, $0 < x < 4$.

6.368. Funksiyaning eng kichik qiymatini toping:

- a) $y = \frac{x+a}{x}$, $a > 0$, $x > 0$; b) $y = x + \frac{20}{x-3}$, $x > 3$;
 d) $y = 7x + \frac{100}{x-3}$, $x > 3$; e) $y = \frac{(x+2)(x+18)}{x}$, $x > 0$.

4- §. Tenglamalar sistemasi

1. Tenglamalar sistemalari va majmualari. x va y o'zgaruvchili

$$\begin{cases} f_1(x, y) = \varphi_1(x, y), \\ f_2(x, y) = \varphi_2(x, y) \end{cases} \quad (1)$$

sistemani yechish — bu shunday $x = a$ va $y = b$ sonlarini topishki, ular sistemaga qo'yilganda to'g'ri tengliklar hosil bo'lsin. Agar sistemaning yechimi $(a_1; b_1)$, $(a_2; b_2)$, ..., $(a_n; b_n)$ sonlar juftlari bo'lsa, javob $\{(a_1; b_1), (a_2; b_2), \dots, (a_n; b_n)\}$ yoki $x_1 = a_1$, $y_1 = b_1$; ...; $x_n = a_n$, $y_n = b_n$ ko'rinishda yoziladi. Bu ko'p o'zgaruvchili tenglamalar sistemalariga ham taalluqli. Odatda sistema tenglamalari soni o'zgaruvchilar soniga teng bo'ladi.

O'zgaruvchilar sistemani qanoatlantiruvchi qiymatlarga ega bo'lmashligi mumkin. Masalan, $\begin{cases} x + y = 7, \\ 3x + 3y = 8 \end{cases}$ sistema yechimga ega emas. Yagona yechimga ega sistema *aniq sistema*, yechimlar soni cheksiz ko'p bo'lsa, *aniqmas sistema*, yechimga ega bo'lmasa (ya'ni yechimlarning bo'sh to'plamiga ega bo'lsa), *birgalikda bo'lmagan (noo'rindosh) sistema* deyiladi. Ko'pincha tenglamalari soni o'zgaruvchilari sonidan ko'p bo'lgan tenglamalar sistemasi noo'rindosh bo'ladi.

1 - m i s o l. Ikki o'zgaruvchili uch tenglamadan iborat ushbu

$$\begin{cases} x + y = 7, \\ x - y = 1, \\ x^2 + y^2 = 12 \end{cases} \quad \text{sistemaning noo'rindosh ekanini isbot qiling.}$$

Y e c h i s h. Oldingi ikki tenglamadan ($x = 4; y = 3$) ni topamiz. U uchinchi tenglamaga qo'yilsa, $4^2 + 3^2 \neq 12$ bo'ladi, ya'ni uchinchi tenglama qanoatlanmaydi. Geometrik ma'nosi: $x^2 + y^2 = 12$ aylana $x + y = 7$ va $x - y = 1$ to'g'ri chiziqlarning kesishish nuqtasi $A(4; 3)$ dan o'tmaydi.

Tenglamalari soni o'zgaruvchilari sonidan kam bo'lgan sistemalar ko'p hollarda noo'rindosh yoki aniqmas bo'ladi.

Masalan, $\begin{cases} x + y + 2z = 1, \\ 2x + 2y + 4z = 5 \end{cases}$ sistema noo'rindosh sistemadir.

2 - m i s o l. Ushbu sistemaning aniqmas sistema ekanligini

ko'rsating: $\begin{cases} x^2 + 4y = 10, \\ x^2 + y - 2z = 3. \end{cases}$

Y e c h i s h. Birinchi tenglamadan $x^2 = 10 - 4y$ ni topib, ikkinchi tenglamaga qo'ysak: $-3y - 2z = -7$ yoki $z = -1,5y + 3,5$. O'zgaruvchi y ga ixtiyoriy qiymat berilib, x va z ning mos qiymatlari topiladi. Sistema cheksiz ko'p yechimga ega. $x^2 = 10 - 4y \geq 0$, demak, y ning qiymatlari $(-\infty; 2,5]$ oraliqdan olinadi.

Tenglamalari soni o'zgaruvchilari soniga teng yoki undan ortiq bo'lgan tenglamalar sistemalari ham aniqmas sistema bo'lishi

mumkin. Masalan,
$$\begin{cases} x^2 - y^2 = 5, \\ 3x^2 - 3y^2 = 15 \end{cases} \text{ va } \begin{cases} x^2 - y^2 = 5, \\ 3x^2 - 3y^2 = 15, \\ 6x^2 - 6y^2 = 30 \end{cases}$$

sistemalar cheksiz ko'p yechimga egadir.

Agar tenglamalar sistemasi *simmetrik* bo'lsa (o'zgaruvchilarni o'rin almashtirish, bir yoki bir necha o'zgaruvchi oldida turgan ishoralarni almashtirishdan sistema tarkibidagi tenglamalar o'zgarmasa), uning *yechimlar to'plami* ham *simmetrik* bo'ladi.

3-misol.
$$\begin{cases} x^2 + y^2 = 41, \\ xy = 20 \end{cases}$$
 sistemaning yechimlaridan biri

(4; 5). O'zgaruvchilarning simmetriyasiga ko'ra (5; 4) ham sistemani qanoatlantiradi. O'zgaruvchilar ishoralari almashtirilsa, tenglamalar o'zgarmaydi. Demak, (-4; -5) va (-5; -4) ham yechim.

Javob: {(4; 5), (5; 4), (-4; -5), (-5; -4)}.

$f_1(x, y) = 0$ va $f_2(x, y) = 0$ tenglamalar berilgan bo'lsin. ularning kamida bittasini qanoatlantiradigan barcha (x; y) juftlarni topish masalasi qo'yilgan bo'lsin. Bunday holda $f_1(x, y) = 0$ va $f_2(x, y) = 0$ tenglamalardan tuzilgan tenglamalar majmuasi berilgan deyiladi. *Tenglamalar majmuasi* tenglamalar siste-

masidan farqli ravishda
$$\begin{cases} f_1(x, y) = 0, \\ f_2(x, y) = 0 \end{cases} \text{ yoki } f_1(x, y) = 0.$$

$f_2(x, y) = 0$ ko'rinishda yoziladi. Majmua tenglamalardan aqalli birini qanoatlantiruvchi (a; b) sonlar juftlarini topish talab qilinayotganini anglatadi. Agar har qaysi tenglama biror chiziqni bersa, majmua shu chiziqlar birlashmasini, ularning

$$\begin{cases} f_1(x, y) = 0, \\ f_2(x, y) = 0 \end{cases}$$
 sistemasi shu chiziqlarning kesishmasini (umu-

miy qismini) beradi, $\left\{ \begin{array}{l} f_1(x, y) = 0, \\ \varphi_1(x, y) = 0; \\ \dots\dots\dots \end{array} \right.$ majmua barcha

$\left\{ \begin{array}{l} f_k(x, y) = 0, \\ \varphi_k(x, y) = 0, \end{array} \right. 1 \leq k \leq n$ sistemalarni yechish va yechimlarini

birlashtirish kerakligini anglatadi.

4 - misol. $\left\{ \begin{array}{l} x + y = 3, \\ xy = 2; \\ x^2 + y^2 = 10, \\ xy = 3 \end{array} \right.$ tenglamalar sistemalari

majmuasini yeching.

Yechish. Birinchi sistema yechimi $\{(2; 1), (1; 2)\}$, ikkinchisidiki $\{(3; 1), (1; 3), (-1; -3), (-3; -1)\}$.

J a v o b : $\{(2; 1), (1; 2), (3; 1), (1; 3), (-1; -3), (-3; -1)\}$.

Agar chiziqli tenglamalar sistemasida ozod hadlardan aqalli biri noldan farqli bo'lsa, u *bir jinsli bo'lmagan tenglamalar sistemasi*, ozod hadlarning hammasi nolga teng bo'lsa, *bir jinsli chiziqli tenglamalar sistemasi* deyiladi.



Mashqlar

Tenglamalar sistemalari majmualarini yeching:

6.369. $\left\{ \begin{array}{l} 2x - y = 3, \\ xy = 2; \\ x^2 - y^2 = 8, \\ x^2 + y^2 = 10. \end{array} \right.$

6.370. $\left\{ \begin{array}{l} x^2 = 4x + 5y, \\ y^2 = 5x + 4y; \\ x^2 + y^2 = 5, \\ xy = 2. \end{array} \right.$

$$6.371. \begin{cases} 2x + y - 3z + 2u = 0, \\ 3x + 3y - 3z + u = 0; \\ 4x - 3y + 3z - u = 0, \\ 5x + 2y - 4z + 2u = 0. \end{cases}$$

$$6.372. \begin{cases} x + 8y = 25, \\ x - y = 1, \\ x + y^2 = 15 \end{cases} \quad \text{sistemaning noo'rindosh ekanini isbot qiling.}$$

6.373. Sistemalar bitta yechimi bilan berilgan. Sistemalarning simmetrikligidan foydalanib, ularning qolgan yechimlarini toping:

$$a) \begin{cases} x^4 + y^4 = 82, \\ x + y = 4. \end{cases} \quad (1; 3); \quad b) \begin{cases} \frac{x^2}{y} + \frac{y^2}{x} = \frac{29}{6}, \\ \frac{1}{x} + \frac{1}{y} = \frac{5}{6}, \end{cases} \quad (2; 3).$$

$$d) \begin{cases} x + y = 1, \\ x^3 + y^3 = 7, \end{cases} \quad (2; -1); \quad e) \begin{cases} x^3 + y^3 = 35, \\ \frac{1}{x} + \frac{1}{y} = \frac{5}{6}, \end{cases} \quad (2; 3);$$

$$f) \begin{cases} x^4 + y^4 = 17, \\ x^2 + y^4 = 5; \\ x + y = 5, \\ x^5 + y^5 = 275. \end{cases} \quad (1; 2), (2; 3).$$

2. Tenglamalar sistemalarining geometrik ma'nosi. Har qanday f uzluksiz funksiyaga Γ chiziq — uning grafigi mos keladi. Lekin har qanday chiziq ham biror funksiyaning grafigi bo'lavermaydi. Masalan, markazi koordinatalar boshida bo'lgan R radiusli aylana hech bir funksiyaning grafigi bo'la olmaydi, chunki aylanada ayni bir x absissali ikkita $(x; \sqrt{R^2 - x^2})$ va $(x; -\sqrt{R^2 - x^2})$ nuqta mavjud. Bu esa x ning har bir joiz qiymatiga

y ning ikkita $+\sqrt{R^2 - x^2}$, $-\sqrt{R^2 - x^2}$ qiymati to'g'ri kelishini ko'rsatadi.

$y = +\sqrt{R^2 - x^2}$ va $y = -\sqrt{R^2 - x^2}$ funksiyalarning grafiklari markazi koordinatalar boshida bo'lgan R radiusli aylanani hosil qiladi. Bu aylananing tenglamasi $x^2 + y^2 = R^2$ dan iborat.

Markazi $A(a; b)$ nuqtada bo'lgan R radiusli aylanani qaraymiz. Uning ixtiyoriy $M(x; y)$ nuqtasidan A markazgacha bo'lgan masofa ham R ga, ham $\sqrt{(x-a)^2 + (y-b)^2}$ ga teng. Shuning uchun,

$\sqrt{(x-a)^2 + (y-b)^2} = R$. Bu tenglikdan, aylana tenglamasi

$$(x-a)^2 + (y-b)^2 = R^2 \quad (1)$$

ni hosil qilamiz. (1) tenglama markazi $A(a; b)$ nuqtada bo'lgan R radiusli aylananing *kanonik* (sodda) *tenglamasi* deyiladi. Bu tenglamani quyidagi ko'rinishda ham yozish mumkin:

$$x^2 + y^2 - 2ax - 2by = C. \quad (2)$$

Bu yerda, $C = R^2 - a^2 - b^2$.

1 - misol. Markazi $M(-2; 3)$ va radiusi $R = 8$ bo'lgan aylananing tenglamasini tuzing.

Yechish. (1) yoki (2) formula bo'yicha:

$$(x+2)^2 + (y-3)^2 = 64 \text{ yoki } x^2 + y^2 + 4x - 6y - 51 = 0.$$

$(x-a)^2 + (y-b)^2 = 0$ tenglama «nol radiusli» aylanani, ya'ni $A(a; b)$ nuqtani ifodalaydi.

Har biri biror chiziqning tenglamasi bo'lgan tenglamalar sistemasini yechish, geometrik jihatdan, shu tenglamalar ifodalagan chiziqning kesishish nuqtalarini topishni anglatadi.

$$2 - \text{misol.} \quad \begin{cases} \left(x + \frac{7}{4}\right)^2 + \left(y - \frac{1}{2}\right)^2 = \frac{85}{16}, \\ y = 0,5x + 2 \end{cases} \text{ tenglamalar sis-}$$

temasini qaraymiz.

Birinchi tenglama markazi $\left(-\frac{7}{4}; \frac{1}{2}\right)$ nuqtada bo'lgan $R = \sqrt{\frac{85}{16}}$ radiusli aylananing, ikkinchi tenglama esa to'g'ri chiziq tenglamasidir. Bu sistemani yechish, geometrik jihatdan, eslatilgan chiziqlar kesishish nuqtalarini topish demakdir.

Chiziqlar $A(0; 2)$, $B(-4; 0)$ nuqtalarda kesishadi. Shuning uchun berilgan sistema $(0; 2)$, $(-4; 0)$ yechimlarga ega.

Tekislikning koordinatalari $f(x; y) \cdot \varphi(x; y) = 0$ tenglamani qanoatlantiruvchi barcha $(x; y)$ nuqtalarining geometrik o'rni tekislikning koordinatalari $f(x; y) = 0$ yoki $\varphi(x; y) = 0$ tenglamani qanoatlantiruvchi barcha $(x; y)$ nuqtalaridan tashkil topadi.

3-misol. Tenglamasi $(x - 8)(y + 9) = 0$ bo'lgan geometrik o'rinni toping. Buning uchun $\begin{cases} x - 8 = 0, \\ y + 9 = 0 \end{cases}$ tenglamalar majmuasidan foydalanamiz. $x - 8 = 0$ tenglamaning yechimi $x = 8$ dan, $y + 9 = 0$ ning yechimi $y = -9$ dan iborat. Geometrik jihatdan majmua $A(8; 0)$ nuqtadan o'tuvchi va Oy o'qqa parallel bo'lgan $x = 8$ to'g'ri chiziq hamda $B(0; -9)$ nuqtadan o'tuvchi va Ox o'qiga parallel bo'lgan $y = -9$ to'g'ri chiziqlarga tegishli nuqtalar to'plamini ifodalaydi.



Mashqlar

6.374. a) Shunday tenglamani tuzingki, uni faqat uchta $A(1; 1)$, $B(-2; 2)$, $C(0; 0)$ nuqtalar qanoatlantiradigan bo'lsin;

b) aylananing markazini va radiusini toping:

1) $x^2 + y^2 + 6x - 4y = 3$; 2) $x^2 + y^2 - 10x - 2y + 1 = 0$;

3) $x^2 + y^2 + 12x - 6y = 4$; 4) $x^2 + y^2 + 10x - 6 = 0$;

d) markazi $A(a; b)$ va radiusi R bo'lgan aylananing tenglamasini tuzing:

1) $a = 2, b = -1, R = 4$; 2) $a = -5, b = 4, R = 8$.

3. Tenglamalar sistemasini grafik usulda yechish. Geometrik

Jihatdan ikki o'zgaruvchili $\begin{cases} f(x, y) = 0, \\ \varphi(x, y) = 0 \end{cases}$ tenglamalar sistemasini

yechish $f(x; y) = 0$ va $\varphi(x; y) = 0$ tenglamalar bilan berilgan Γ_1 va Γ_2 chiziqlarning kesishish nuqtalari koordinatalarini izlashdan iborat. Grafik usuldan yechimni taqribiy baholashda foydalaniladi. Chizmalar mumkin qadar aniq chizilishi kerak. Millimetrli qog'ozlardan foydalangan ma'qul.

1 - misol. $\begin{cases} x^2 + 6x - y = -9, \\ 2x + y = 2 \end{cases}$ tenglamalar sistemasini grafik

usulda yeching.

Yechish. Birinchi tenglama $y = x^2 + 6x + 9$, ya'ni $y = (x + 3)^2$ parabolani (Γ_1 ni), ikkinchi tenglama esa $y = -2x + 2$ to'g'ri chiziqni (Γ_2 ni) beradi (25- rasm). Bu chiziqlar $A(-7; 16)$ va $B(-1; 4)$

nuqtalarda kesishadi. Sistemaning yechimi: $\begin{cases} x_1 = -7, \\ y_1 = 16 \end{cases}$ va $\begin{cases} x_2 = -1, \\ y_2 = 4. \end{cases}$

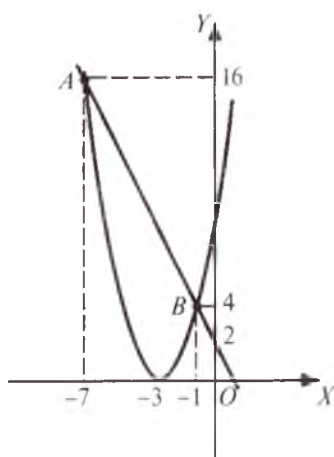

25- rasm.

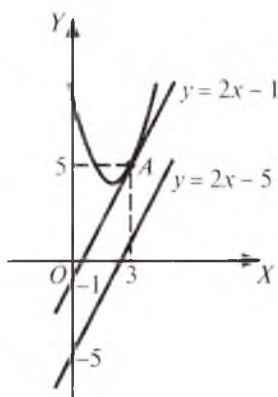

26- rasm.

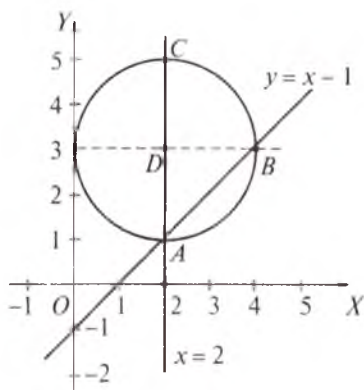

27- rasm.

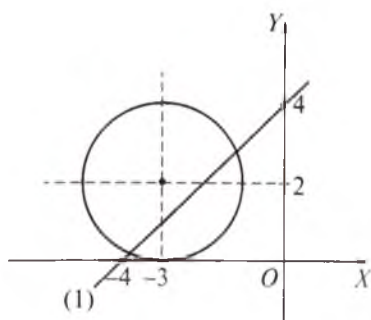

28- rasm.

2 - misol. 26- rasmda $\begin{cases} y = x^2 - 4x + 8, \\ y = 2x - 1 \end{cases}$ tenglamalar sistemasi

ni grafik yechish tasvirlangan. $y = 2x - 1$ to'g'ri chiziq $A(3; 5)$ nuqtada $y = x^2 - 4x + 8 = (x - 2)^2 + 4$ parabola ga urinadi. Demak, sistema yagona yechimga ega: $x = 3, y = 5$.

3 - misol. $\begin{cases} y = x^2 - 4x + 8, \\ y = 2x - 5 \end{cases}$ sistemani grafik usulda yeching.

Yechish. Yechim 26- rasmda tasvirlangan. $y = x^2 - 4x + 8$ parabola va $y = 2x - 5$ to'g'ri chiziq kesishmaydi. Sistema yechimga ega emas.

4 - misol. $\begin{cases} x^2 + y^2 - 4x - 6y + 9 = 0, \\ x^2 - xy - 3x + 2y + 2 = 0 \end{cases}$ tenglamalar sistemasi

sini grafik usulda yeching.

Yechish. Birinchi tenglamani $(x - 2)^2 + (y - 3)^2 = 4$ ko'rinishga keltiramiz. Uning grafigi markazi $D(2; 3)$ nuqtada bo'lgan $R = 2$ radiusli aylanadan iborat.

Ikkinchi tenglama chap qismini ko'paytuvchilarga ajratish bilan $(x - 2)(x - y - 1) = 0$ tenglamaga keladi. Uning grafigi $x = 2$ va $y = x - 1$ tenglamalar bilan aniqlangan to'g'ri chiziq birlashmasidan iborat.

Ayni bir koordinatalar tekisligida yuqorida aytilgan aylananing VII to'g'ri chiziqlarni yasaymiz (27- rasm). Ular $A(2; 1)$, $B(4; 3)$ va $C(2; 5)$ nuqtalarda kesishadi. Demak, berilgan sistema uchta yechimga ega: $(2; 1)$, $(4; 3)$, $(2; 5)$.



Mashqlar

6.375. Quyidagi tenglamalar sistemalarini grafik usulda yeching, topilgan javoblarni o'rniga qo'yish usuli bilan tekshiring:

$$a) \begin{cases} x^2 = y - 4, \\ y^2 = x + 10 \end{cases}$$

$$b) \begin{cases} x^2 - 4x - 9y = 14, \\ y^2 + 6y - x = -10; \end{cases}$$

$$d) \begin{cases} x^2 + y^2 = 2, \\ xy = 1; \end{cases}$$

$$e) \begin{cases} x^2 + 6x - 3y = -14, \\ x^2 + 4y = 13; \end{cases}$$

$$f) \begin{cases} x^2 + y^2 = -8, \\ x^2 + (y - 9)^2 = 125; \end{cases}$$

$$g) \begin{cases} x^2 - (y - 1)^2 = -1, \\ x^2 + y^2 = 4. \end{cases}$$

6.376. 28- rasmda tasvirlangan (1) to'g'ri chiziq koordinata o'qlarini $x = -4$ va $y = 4$ nuqtalarda kesadi, aylana Ox o'qqa $x = -3$ nuqtada urinadi. Ularning tenglamalarini tuzing va kesishish nuqtalari koordinatalarini toping.

4. Teng kuchli sistemalar. Ko'paytuvchilarga ajratish usuli.

Tenglamalar sistemalarini yechishda ularni $\begin{cases} x = a, \\ y = b \end{cases}$ ko'rinishdagi eng oddiy tenglamalar sistemasiga yoki sistemalar majmuasiga kelguncha teng kuchli sistemalar bilan almashtiriladi. Agar ikki tenglamalar sistemasi bir xil yechimga ega bo'lsa, ular *teng kuchli sistemalar* deyiladi. Agar ularning X_1 va X_2 yechimlari har xil, lekin bu yechimlarning biror Y to'plam bilan kesishmalari bir xil bo'lsa, ular *Y to'plamda teng kuchli bo'lgan sistemalar* deyiladi. Har qanday ikki noo'rindosh sistema ham o'zaro teng kuchlidir, chunki ularning ikkalasi ham bo'sh to'plamdan iborat yechimga ega. Odatda teng kuchlilik « \sim » belgi orqali belgilanadi.

Tenglamalar sistemalarini yechishda bir o'zgaruvchili tenglamalarni yechishdagi kabi ko'paytuvchilarga ajratish ham qo'llaniladi. Bu usul quyidagi teoreмага asoslanadi:

Teorema. *Biror X to'plamda aniqlangan $f_1(x, y), \dots, f_n(x, y)$ funksiyalar qatnashgan*

$$\begin{cases} f_1(x, y) \cdot \dots \cdot f_n(x, y) = 0, \\ \varphi(x, y) = 0 \end{cases} \quad (1)$$

tenglamalar sistemasi shu to'plamda

$$\begin{cases} f_1(x, y) = 0, & \dots & f_n(x, y) = 0, \\ \varphi(x, y) = 0; & \dots & \varphi(x, y) = 0 \end{cases} \quad (2)$$

tenglamalar sistemalari majmuasiga teng kuchlidir.

Isbot. $(a; b)$ sonlar jufti (1) sistemani qanoatlantirsin. U holda ko'paytuvchilar orasida hech bo'lmaganda bittasi nolga teng bo'lishi kerak, $f_k(a, b) = 0$, $1 \leq k \leq n$. Shunga ko'ra, $(a; b)$ jufti

$$\begin{cases} f_k(x, y) = 0, \\ \varphi(x, y) = 0 \end{cases} \text{ tenglamalar sistemasini, demak, (2) tenglamalar}$$

sistemalari majmuasini ham qanoatlantiradi. Aksincha, agar $(a; b)$ sonlar jufti (2) majmuani qanoatlantirsa, u holda shunday

$$k - \text{ko'paytuvchi mavjud bo'ladiki, unda bu sonlar jufti } \begin{cases} f_k(x, y) = 0, \\ \varphi(x, y) = 0, \end{cases}$$

$1 \leq k \leq n$, sistemani ham qanoatlantiradi, ya'ni $f_k(a, b) = 0$, $\varphi(a; b) = 0$ bo'ladi. Barcha f_k funksiyalar X to'plamda aniqlanganligidan, ular $M(a, b)$ nuqtada ham aniqlangandir va shuning uchun $f_1 \cdot \dots \cdot f_n$ ko'paytma ham nolga aylanadi. Demak, $(a; b)$ jufti (2) sistemani qanoatlantiradi.

1-misol.

$$\begin{cases} (x^2 + y^2 - 13)(x + y - 7) = 0, \\ xy = 6 \end{cases} \quad (3)$$

sistemani yeching.

$$\text{Yechish. (3)} \Leftrightarrow \begin{cases} x^2 + y^2 - 13 = 0, \\ xy = 6; \\ x + y - 7 = 0, \\ xy = 6 \end{cases} \Leftrightarrow$$

$$\Leftrightarrow \left\{ \begin{array}{l} \{(2; 3), (3; 2), (-2; -3), (-3; -2)\}; \\ \{(1; 6), (6; 1)\}. \end{array} \right.$$

Javob: $\{(2; 3), (3; 2), (-2; -3), (-3; -2), (1; 6), (6; 1)\}$ yoki

$$\begin{cases} x_1 = 2, & x_2 = 3, & x_3 = -2, & x_4 = -3, & x_5 = 1, & x_6 = 6, \\ y_1 = 3; & y_2 = 2; & y_3 = -3; & y_4 = -2; & y_5 = 6; & y_6 = 1. \end{cases}$$

Agar sistema $\begin{cases} f_1(x, y) \cdot \dots \cdot f_n(x, y) = 0, \\ \varphi_1(x, y) \cdot \dots \cdot \varphi_m = 0 \end{cases}$ ko'rinishda berilsa,

uni yechish $\begin{cases} f_k(x, y) = 0, \\ \varphi_l(x, y) = 0 \end{cases}$ sistemalar majmuasini yechishga

keladi, $1 \leq k \leq n, 1 \leq l \leq m$.

Ushbu $\begin{cases} f(x, y) = 0, \\ g(x, y) = 0 \end{cases}$ sistemada f va g ko'phadlardan biri,

masalan, $f(x, y)$ x va y ga nisbatan bir jinsli bo'lsin va uning barcha hadlari x^k ga bo'linsin. U holda x^k umumiy ko'paytuvchi qavsdan tashqariga chiqariladi, ko'phad $f(x, y) = x^k \cdot f_1(x, y)$ ko'paytma ko'rinishiga keladi va berilgan sistemani yechish ma-

salasi $\begin{cases} x^k = 0, & f_1(x, y) = 0, \\ g(x, y) = 0; & g(x, y) = 0 \end{cases}$ majmuani yechishga keladi.

2- misol. $\begin{cases} 2x^3 + 3x^2y - 2xy^2 = 0, \\ x^2 + 2y^2 = 9 \end{cases}$ tenglamalar sistemasini

yeching.

Yechish. Sistemaning birinchi tenglamasi bir jinsli, chap qismi x ga bo'linadi. x ni qavsdan tashqariga chiqaramiz. Masala ushbu majmuani yechishga keladi:

$$\begin{cases} x = 0, & \begin{cases} 2x^2 + 3xy - 2y^2 = 0, \\ x^2 + 2y^2 = 9; \end{cases} \\ x^2 + 2y^2 = 9; & \begin{cases} x^2 + 2y^2 = 9. \end{cases} \end{cases}$$

Birinchi sistema $x = 0$, $y^2 = \frac{9}{2}$ sistemaga teng kuchli, undan

$x_1 = 0$, $y_1 = \frac{3\sqrt{2}}{2}$ yoki $x_2 = 0$, $y_2 = -\frac{3\sqrt{2}}{2}$ ni topamiz. Ikkinchi sistema yechimi: $(1; 2)$, $(-1; -2)$.

Ikkala sistema yechimlari majmuasi $\left\{ \left(0; \frac{3\sqrt{2}}{2} \right); \right.$

$\left. \left(0; -\frac{3\sqrt{2}}{2} \right); (1; 2); (1; -2) \right\}$ berilgan sistema yechimini beradi.



Mashqlar

6.377. Sistemalarni teng kuchlilikka tekshiring va ularni yeching:

a) $\begin{cases} 2x + y = 7, \\ 3x - 4 = 1 \end{cases}$ va $\begin{cases} (2x + y)(x^2 + y^2) = 7(x^2 + y^2), \\ (3x - 4)(x - y) = x - y; \end{cases}$

b) $\begin{cases} 2x + y = 7, \\ 3x - 4 = 1 \end{cases}$ va $\begin{cases} \frac{2x+7}{x^2+y^2} = \frac{7}{x^2+y^2}, \\ \frac{3x-4}{x-y} = \frac{1}{x-y}; \end{cases}$

d) $\begin{cases} x + 2 = y + 2, \\ x - 2 = 0 \end{cases}$ va $\begin{cases} x^2 = 4, \\ y = -\sqrt{x}; \end{cases}$

e) $\begin{cases} \sqrt{x} = y^2, \\ \sqrt{y} = x^2 \end{cases}$ va $\begin{cases} x^2 = y^4, \\ y^2 = x^4. \end{cases}$

5. Tenglamalar sistemasini algebraik qo'shish usuli yordamida yechish. Bu usul bizga tanish. Uning asosida ushbu teorema yotadi.

Teorema. $(a; b)$ sonlar juftlarida aniqlangan $\psi(x; y)$, $f(x; y)$, $\varphi(x; y)$ funksiyalarning

$$\begin{cases} f(x; y) = 0, \\ \varphi(x; y) = 0 \end{cases} \quad (1)$$

sistemi

$$\begin{cases} f(x; y) = 0, \\ \varphi(x; y) + \psi(x; y)f(x; y) = 0 \end{cases} \quad (2)$$

sistemaga teng kuchlidir.

Isbot. Agar $(a; b)$ sonlar jufti (1) sistemani qanoatlantirsa, ya'ni $f(a; b) = 0$, $\varphi(a; b) = 0$ bo'lsa, $\psi(a; b) \times f(a; b) = 0$ bo'ladi, bundan $\varphi(a; b) + \psi(a; b) \cdot f(a; b) = 0$ kelib chiqadi. Demak, $(a; b)$ juft (2) tenglamalar sistemasini qanoatlantiradi. Aksincha, $(a; b)$ sonlar jufti (2) sistemani qanoatlantirsa, ya'ni $f(a; b) = 0$, $\varphi(a; b) + \psi(a; b) \cdot f(a; b) = 0$ bo'lsa, $\varphi(a; b) = 0$ tenglik ham to'g'ri bo'ladi. Shunga ko'ra $(a; b)$ jufti (1) sistemani qanoatlantiradi. Teorema isbot qilindi.

Misol.
$$\begin{cases} x^2 + 3y^2 + 2x - y = 7, \\ 2x^2 + 6y^2 - 2x + 4y = 2 \end{cases} \quad (3)$$
 tenglamalar sistema-

sini yechamiz.

Yechish. Ikkinchi tenglamani -2 ga bo'lib, birinchi tenglamaga hadlab qo'shamiz va almashtirishlarni bajaramiz:

$$\begin{aligned} (3) &\Leftrightarrow \begin{cases} x^2 + 3y^2 + 2x - y = 7, \\ -x^2 - 3y^2 + x - 2y = -1 \end{cases} \Leftrightarrow \\ &\Leftrightarrow \begin{cases} x^2 + 3y^2 + 2x - y = 7, \\ 3x - 3y = 6 \end{cases} \Leftrightarrow \\ &\Leftrightarrow \begin{cases} x^2 + 3(x-2)^2 + 2x - (x-2) = 7, \\ y = x - 2 \end{cases} \Leftrightarrow \end{aligned}$$

$$\Leftrightarrow \begin{cases} 4x^2 - 11x + 7 = 0, \\ y = x - 2. \end{cases}$$

Bundan $(1; -1)$, $(1\frac{3}{4}; -\frac{1}{4})$ yechimlarni hosil qilamiz.



Mashqlar

6.378. Sistemalarni yeching:

$$\text{a) } \begin{cases} x^2 + xy + 2y^2 = 7, \\ 2x^2 + 2xy + y^2 = 2; \end{cases} \quad \text{b) } \begin{cases} x^2 + xy = 12, \\ xy - y^2 = 2. \end{cases}$$

6. Noma'lumlarni chiqarish usuli. Gauss usuli. Bu usul asosida tenglamalar sistemasi yoki majmuasini ayniy almashtirishlar bilan o'zgaruvchilar soni bitta kam bo'lgan teng kuchli tenglamalar sistemasi yoki majmuasiga keltirish haqidagi fikr yotadi:

$\begin{cases} y = f(x), \\ \varphi(x; y) = 0; \end{cases} \Leftrightarrow \begin{cases} y = f(x), \\ \varphi(x; f(x)) = 0. \end{cases}$ Masala $\varphi(x; f(x)) = 0$ tenglamadan x ni aniqlash, so'ng $y = f(x)$ bo'yicha y ni topish bilan hal bo'ladi.

$\begin{cases} f(x) = 0, \\ \varphi(x; y) = 0 \end{cases}$ ko'rinishdagi sistemani yechish uchun, oldin tenglamalardan biri o'zgaruvchilardan biriga nisbatan yechiladi.

1- misol. $\begin{cases} xy = 8, \\ x^2 + y^2 = 20 \end{cases}$ tenglamalar sistemasini yeching.

Yechish. Birinchi tenglamadan $y = \frac{8}{x}$ ni topib, ikkinchi tenglamaga qo'ysak: $x^2 + \frac{64}{x^2} = 20$ yoki soddalashtirishlardan so'ng $x^4 - 20x^2 + 64 = 0$ bikvadrat tenglama olinadi. Uning ildizlari: $x_1 = 2, x_2 = 4, x_3 = 2, x_4 = -4$. Bu ildizlarga $y_1 = 4, y_2 = 2, y_3 = -4, y_4 = -2$ mos keladi.

2- misol. Uch noma'lumli ikki tenglamadan iborat

$$\begin{cases} x + y = 6, \\ xy - z^2 = 9 \end{cases} \quad (1) \text{ sistemani yeching.}$$

$$\begin{aligned} \text{Yechish. (1)} &\Leftrightarrow \begin{cases} y = 6 - x, \\ xy = 9 + z^2 \end{cases} \Leftrightarrow \begin{cases} y = 6 - x, \\ xy \geq 9 \end{cases} \Leftrightarrow \\ &\Leftrightarrow \begin{cases} y = 6 - x, \\ x(6 - x) \geq 9 \end{cases} \Leftrightarrow \begin{cases} y = 6 - x, \\ x^2 - 6x + 9 \leq 0 \end{cases} \Leftrightarrow \begin{cases} y = 6 - x, \\ (x - 3)^2 \leq 0 \end{cases} \Leftrightarrow \\ &\Leftrightarrow \begin{cases} y = 6 - x, \\ (x - 3)^2 = 0 \end{cases} \Leftrightarrow \{x = 3, y = 3, z = 0\}. \end{aligned}$$

Chiziqli tenglamalar sistemasini yechishda, xususan, tenglamalar soni ko'p bo'lgan holda, *Gaussning noma'lumlarni ketma-ket chiqarish usulidan* foydalanish ma'qul (Karl Fridrix Gauss (1777–1855), buyuk nemis matematigi). Usulning mohiyatini misol yordamida tushuntiramiz.

$$\text{3-misol. } \begin{cases} 2x + 7y - 4z = -13, \\ 5x + 10y - z = -7, \\ 4x - 6y + z = 12 \end{cases} \text{ sistemani Gauss usuli bilan}$$

yeching.

Yechish. 1-qadam: a) birinchi tenglamadagi x o'zgaruvchi oldidagi koeffitsiyentni 1 ga aylantiramiz. Buning uchun shu tenglamani 2 ga bo'lamiz. Natijada tenglama $x + \frac{7}{2}y - 2z = -\frac{13}{2}$

(2) ko'rinishni oladi;

b) sistemaning ikkinchi tenglamasidan beshga ko'paytirilgan (2) tenglamani, uchinchi tenglamasidan esa 4 ga ko'paytirilgan (2) tenglamani ayirsak, ushbu sistema hosil bo'ladi:

$$\begin{cases} x + \frac{7}{2}y - 2z = -\frac{13}{2}, \\ \frac{15}{2}y - 9z = -\frac{51}{2}, \\ 20y - 9z = -38. \end{cases} \quad (3)$$

Bu sistemaning ikkinchi va uchinchi tenglamalarida x o'zgaruvchi qatnashmaydi.

2- q a d a m: a) (3) sistema ikkinchi tenglamasini $15/2$ ga bo'lsak, bosh koeffitsiyenti 1 ga aylanadi, so'ng tenglamani 20 ga ko'paytirib, uchinchi tenglamadan ayiramiz. Uchinchi tenglamadan y o'zgaruvchi chiqarilgan bo'ladi va sistema uchbu chaksimon shaklga keladi:

$$\begin{cases} x + \frac{7}{2}y - 2z = -\frac{13}{2}, \\ y - \frac{6}{5}z = -\frac{17}{5}, \\ -15z = -30. \end{cases} \quad (4)$$

b) teskari q a d a m: (4) sistemaning uchinchi tenglamasidan $z = 2$ topiladi, bu qiymat ikkinchi tenglamaga qo'yilib, $y = -1$, so'ng $z = 2$, $y = -1$ lar birinchi tenglamaga qo'yilib, $x = 1$ topiladi. J a v o b: $(1; -1; 2)$. Albatta, (3) sistemaning ikkinchi va uchinchi tenglamalarida z ning koeffitsiyentlari bir xil ekanidan foydalanib, ularning biridan ikkinchisini ayirish ham mumkin edi.

Gauss usuli qo'llanilishi jarayonida $0 \cdot x = 5$ yoki o'zgaruvchilarning izlanayotgan qiymatlari musbat bo'lish sharti qo'yilgan holda $5x + 4y = -1$ kabi zid ma'noli ifodalar hosil bo'lsa, sistema noo'rindosh bo'ladi. Shuningdek, natija trapetsiyasimon sistemani hosil qilish bilan tugasa, sistema cheksiz ko'p yechimga ega bo'ladi.

$$\begin{aligned} \text{4- misol. } \begin{cases} x + y - z = 3, \\ 2x - y - 3z = -1, \\ x - 2y - 2z = -4 \end{cases} &\Rightarrow \begin{cases} x + y - z = 3, \\ 3y + z = 7, \\ 3y + z = 7 \end{cases} \Rightarrow \\ \Rightarrow \begin{cases} x = 3 - y + z, \\ z = 7 - 3y, \end{cases} &\Rightarrow \begin{cases} x = 10 - 4y, \\ z = 7 - 3y. \end{cases} \end{aligned}$$

Yechim cheksiz ko'p. Masalan, $y=0$ bo'lsa, $z=7$, $x=10$ bo'ladi. J a v o b: $\{(10 - 4y; y; 7 - 3y) | y \in R\}$.



6.379. Sistemalarni yeching:

$$\text{a) } \begin{cases} x + 4y - z = -7, \\ 5x + 10y - z = -7, \\ 4x - 6y + z = 12; \end{cases}$$

$$\text{b) } \begin{cases} 3x - 4y + 5z = 17, \\ 2x + 4y - 3z = -8, \\ x - 6y + 8z = 23; \end{cases}$$

$$\text{d) } \begin{cases} z + 5 = 3x, \\ 2x + 6y + 4z = 10, \\ 8y - 5x + 8 = 19; \end{cases}$$

$$\text{e) } \begin{cases} x + y + z = 6, \\ 2x + y - z = -4, \\ 3x - y + z = 4; \end{cases}$$

$$\text{f) } \begin{cases} x + y + z = 14, \\ x + 2y + t = 7, \\ y + 2z + 2t = 30, \\ x + z + t = 15; \end{cases}$$

$$\text{g) } \begin{cases} x + 2y - z + 2t = -7, \\ 3x - y + 2z + 6t = 1, \\ 2x + 8y - 3z + 5t = -23, \\ 4x + y + 12z - 3t = 49; \end{cases}$$

$$\text{h) } \begin{cases} 2,8x + 3,4y + 1,4z = 2,2, \\ 3,6x - 1,8y + 2,9z = 1,8, \\ 4,2x + 5,2y - 1,7z = 0,9; \end{cases}$$

$$\text{i) } \begin{cases} 2x + 3y + z - 2t = -2, \\ 3x + 2y - 2z + 3t = 1, \\ 4x - 2y + 2z - 3t = 6. \end{cases}$$

7. O'zgaruvchilarni almashtirish usuli. Tenglamalarni yechishda bu usuldan foydalanamiz. Usul qo'llanilganda berilgan sistemadagi ayrim ifodalar yangi o'zgaruvchilar sifatida qabul qilinadi. Natijada sistema nisbatan sodda sistemaga keladi. Yangi sistema yechilgach, tanlangan ifodalarning qiymatlari, so'ng ular bo'yicha oldingi o'zgaruvchilarning izlanayotgan qiymatlari topiladi. Xususan, bu almashtirishlar simmetrik tenglamalar sistemalariga nisbatan bajariladi.

1- misol. Ushbu sistemani yeching:

$$\begin{cases} x^3y + xy^3 = 10, \\ xy + x^2 + y^2 = 7. \end{cases} \quad (1)$$

Yechish. Birinchi tenglamada xy ni qavsdan tashqariga chiqarsak, $xy(x^2 + y^2) = 10$ tenglama hosil bo'ladi. $xy = u$, $x^2 + y^2 = v$ almashtirish kiritamiz. Berilgan sistemaga nisbatan sodda sistema

hosil bo'ladi: $\begin{cases} uv = 10, \\ u + v = 7. \end{cases}$ Bu sistemaning yechimi: $(u = 2; v = 5)$,

$(u = 5; v = 2)$.

$$(1) \text{ sistema } \begin{cases} xy = 2, \\ x^2 + y^2 = 5 \end{cases} \quad (2), \quad \begin{cases} xy = 5, \\ x^2 + y^2 = 2 \end{cases} \quad (3) \text{ tenglamalar}$$

sistemalari majmuasiga keladi:

$$(2) \Leftrightarrow \begin{cases} x^2 + y^2 - 2xy = 1, \\ x^2 + 2xy + y^2 = 9 \end{cases} \Leftrightarrow \begin{cases} (x - y)^2 = 1, \\ (x + y)^2 = 9 \end{cases} \Leftrightarrow$$

$$\Leftrightarrow \begin{cases} \begin{cases} x - y = 1, \\ x + y = 3; \end{cases} \\ \begin{cases} x - y = 1, \\ x + y = -3; \end{cases} \\ \begin{cases} x - y = -1, \\ x + y = 3; \end{cases} \\ \begin{cases} x - y = -1, \\ x + y = -3. \end{cases} \end{cases} \Leftrightarrow \{(2; 1), (-1; -2), (1; 2), (-2; -1)\}.$$

$$(3) \Leftrightarrow \begin{cases} (x - y)^2 = -3, \\ (x + y)^2 = 12 \end{cases} \Leftrightarrow \emptyset. \text{ Bu sistema no o'rindosh.}$$

2- misol. $\begin{cases} x^2 + xy + y^2 = 39, \\ x + xy + y = 17 \end{cases}$ tenglamalar sistemasini

yeching.

Yechish. Tenglamalarning chap qismi x va y ga nisbatan simmetrik. $u = x + y$, $v = xy$ o'zgaruvchilarni kiritamiz, $x^2 + xy +$

$+ y^2 = (x + y)^2 - xy = u^2 - v$, $x + xy + y = u + v$. Sistema $\begin{cases} u^2 - v = 39, \\ u + v = 17 \end{cases}$

ko'rinishga keladi. Bu tenglamalarni qo'shsak, $u^2 + u - 56 = 0$ kvadrat tenglama hosil bo'ladi. Undan $u = 7$ yoki $u = -8$ topiladi. Sistemaning ikkinchi tenglamasidan $v = 10$ yoki $v = 25$ olinadi. Natijada berilgan tenglamalar sistemasi ikki sistema majmuasiga

keladi: $\begin{cases} x + y = 7, \\ xy = 10; \end{cases} \begin{cases} x + y = -8, \\ xy = 25. \end{cases}$ Birinchi sistemani yechib,

javobni olamiz: $\{(2; 5), (5; 2)\}$. Ikkinchi sistema yechimga ega emas.



Mashqlar

6.380. Sistemani o'rniga qo'yish usuli bilan yeching:

a) $\begin{cases} x - y = 5, \\ 2x + 3y = 5; \end{cases}$

b) $\begin{cases} 2x - y = 1, \\ 3x + 4y = 5; \end{cases}$

d) $\begin{cases} x + y = 5, \\ 2x + 2y = 10; \end{cases}$

e) $\begin{cases} \frac{1}{2}x - y = 5, \\ x - 9y = 31; \end{cases}$

f) $\begin{cases} \frac{1}{2}x + \frac{1}{3}y = 6, \\ \frac{x}{5} + \frac{y}{4} = 3\frac{9}{20}; \end{cases}$

g) $\begin{cases} \frac{3}{4}x - \frac{5}{7}y = \frac{23}{168}, \\ 21x - 20y = 21; \end{cases}$

h) $\begin{cases} 0,3x - y = \frac{4}{7}, \\ 30x - 10y = \frac{40}{7}; \end{cases}$

i) $\begin{cases} 0,3x - 4y = \frac{1}{3}, \\ 0,7x - 7y = 43. \end{cases}$

6.381. Sistemani algebraik qo'shish usulida yeching:

$$\text{a) } \begin{cases} x - y = -1, \\ 4x + y = 6; \end{cases}$$

$$\text{b) } \begin{cases} 2x + y = 2, \\ -2x - y = 3; \end{cases}$$

$$\text{d) } \begin{cases} 2x + 3y = 7, \\ -4x - 6y = -14; \end{cases}$$

$$\text{e) } \begin{cases} 2x + 3y = 2, \\ \frac{1}{2}x + 3y = -\frac{11}{8}; \end{cases}$$

$$\text{f) } \begin{cases} 2x + 3y = \frac{281}{143}, \\ 3x + 4y = \frac{405}{143}; \end{cases}$$

$$\text{g) } \begin{cases} 3,1x + \frac{1}{13}y = 1, \\ 3,1x + \frac{1}{11}y = 3. \end{cases}$$

6.382. Sistemani Gauss usuli bilan yeching:

$$\text{a) } \begin{cases} x + y + z = 1, \\ 2x + 3y - 2z = 7, \\ 3x + 2y + 5z = 0; \end{cases}$$

$$\text{b) } \begin{cases} x + y - z = -1, \\ 3x - 2y + 4z = 9, \\ 2x + 3y + 2z = 1; \end{cases}$$

$$\text{d) } \begin{cases} x - y + z = -1, \\ 2x + 3y + 4z = 5, \\ 3x - 2y - 2z = -7; \end{cases}$$

$$\text{e) } \begin{cases} x - y - z = -1, \\ 4x + 5y - 3z = 6, \\ 2x + 3y - 2z = 3; \end{cases}$$

$$\text{f) } \begin{cases} -x + y + z = -3, \\ 2x + 2y - 3z = 3, \\ 3x + 4y + 5z = -6; \end{cases}$$

$$\text{g) } \begin{cases} -x - y + z = 3, \\ 5x + 2y + 3z = -4, \\ 3x + 4y - 2z = -9. \end{cases}$$

6.383. Sistemani yeching:

$$\text{a) } \begin{cases} x - y = 1, \\ x^2 + y^2 = 1; \end{cases}$$

$$\text{b) } \begin{cases} x^2 - 3xy - 2y^2 = 2, \\ x + 2y = 1; \end{cases}$$

$$\text{d) } \begin{cases} y - 2x = 2, \\ 5x^2 - y = 1; \end{cases}$$

$$\text{e) } \begin{cases} x - 2y + 1 = 0, \\ 5xy + y^2 = 16; \end{cases}$$

$$\text{f) } \begin{cases} x + y = 4, \\ y + xy = 6; \end{cases}$$

$$\text{g) } \begin{cases} 2x^2 - xy = 33, \\ 4x - y = 17. \end{cases}$$

6.384. Sistemani yeching:

$$\begin{array}{lll} \text{a)} \begin{cases} x + y = 5, \\ xy = 6; \end{cases} & \text{b)} \begin{cases} x + y = 3, \\ xy + 4 = 0; \end{cases} & \text{d)} \begin{cases} x + y = 7, \\ xy = 12; \end{cases} \\ \text{e)} \begin{cases} x - y = 5, \\ xy = -6; \end{cases} & \text{f)} \begin{cases} x - y = 9, \\ xy = -20; \end{cases} & \text{g)} \begin{cases} x - y = 10, \\ xy = -21. \end{cases} \end{array}$$

6.385. Sistemani yeching:

$$\begin{array}{ll} \text{a)} \begin{cases} \frac{x}{25} + \frac{y}{9} = 1, \\ x^2 + y^2 = 1; \end{cases} & \text{b)} \begin{cases} 8x + 7y = 56, \\ x^2 + y^2 - 4y = 0; \end{cases} \\ \text{d)} \begin{cases} x + y = 1, \\ x^2 + xy + y = 1; \end{cases} & \text{e)} \begin{cases} x - 2y = -3, \\ -2y^2 + xy + 3y = 0. \end{cases} \end{array}$$

6.386. Sistemani yeching:

$$\begin{array}{ll} \text{a)} \begin{cases} x^2 + y^2 = 20, \\ xy = 8; \end{cases} & \text{g)} \begin{cases} y^2 - xy = 12, \\ x^2 - xy = 28; \end{cases} \\ \text{b)} \begin{cases} x^2 + y^2 = 68, \\ xy = 16; \end{cases} & \text{h)} \begin{cases} x^2 + y^2 = 25 - 2xy, \\ y(x + y) = 10; \end{cases} \\ \text{d)} \begin{cases} x(x + y) = 9, \\ y(x + y) = 16; \end{cases} & \text{i)} \begin{cases} 5(x + y) + 2xy = -19, \\ 15xy + 5(x + y) = -175; \end{cases} \\ \text{e)} \begin{cases} x^2 + xy = 15, \\ y^2 + xy = 10; \end{cases} & \text{j)} \begin{cases} 5(x + y) + 2xy = -19, \\ 3xy + x + y = -35; \end{cases} \\ \text{f)} \begin{cases} x^2 - xy = 28, \\ y^2 - xy = -12; \end{cases} & \text{k)} \begin{cases} 4x^2 + y^2 - 2xy = 7, \\ (2x - y)y = y. \end{cases} \end{array}$$

6.387. Sistemani yeching:

$$\begin{array}{ll} \text{a)} \begin{cases} x + y + xy = 5, \\ x^2 + y^2 + xy = 7; \end{cases} & \text{b)} \begin{cases} 2y^2 - xy + 3x^2 = 17, \\ y^2 - x^2 = 16; \end{cases} \end{array}$$

$$d) \begin{cases} x^2 - xy + y^2 = 21, \\ y^2 - 2xy + 15 = 0; \end{cases}$$

$$e) \begin{cases} 2y^2 + xy - x^2 = 0, \\ x^2 - xy - y^2 + 3x + 7y + 3 = 0; \end{cases}$$

$$f) \begin{cases} xy + 3y^2 - x + 4y - 7 = 0, \\ 2xy + y^2 - 2x - 2y + 1 = 0; \end{cases}$$

$$g) \begin{cases} 2xy + y^2 - 4x - 3y + 2 = 0, \\ xy + 3y^2 - 2x - 14y + 16 = 0; \end{cases}$$

$$h) \begin{cases} 3x^2 + xy - 2x + y - 5 = 0, \\ 2x^2 - xy - 3x - y - 5 = 0; \end{cases}$$

$$i) \begin{cases} 2x^2 + y^2 + 3xy = 12, \\ 2(x + y)^2 - y^2 = 14. \end{cases}$$

6.388. Sistemani yeching:

$$a) \begin{cases} xy - x + y = 1, \\ x^2y - xy^2 = 30; \end{cases}$$

$$b) \begin{cases} xy + x - y = 3, \\ x^2y - xy^2 = 2; \end{cases}$$

$$d) \begin{cases} x^2 + xy + x = 10, \\ y^2 + xy + y = 20; \end{cases}$$

$$e) \begin{cases} x^2 + xy + 2y^2 = 37, \\ 2x^2 + 2xy + y^2 = 26. \end{cases}$$

6.389. Sistemani yeching:

$$a) \begin{cases} x^3 + y^3 = 35, \\ x + y = 5; \end{cases}$$

$$b) \begin{cases} x^4 + y^4 = 82, \\ xy = 3; \end{cases}$$

$$d) \begin{cases} x - y = 1, \\ x^3 - y^3 = 7; \end{cases}$$

$$e) \begin{cases} x^3 + y^3 = 7, \\ x^3y^3 = -8; \end{cases}$$

$$f) \begin{cases} x^3 + y^3 = 7, \\ xy(x + y) = -2; \end{cases}$$

$$g) \begin{cases} (x^2 + y^2)xy = 78, \\ x^4 + y^4 = 97; \end{cases}$$

$$h) \begin{cases} \frac{x^2}{y} + \frac{y^2}{x} = 18, \\ x + y = 12; \end{cases}$$

$$i) \begin{cases} x^3 + y^3 = 19, \\ x - y = 5. \end{cases}$$

6.390. Sistemani yeching:

$$a) \begin{cases} x + y = z = 13, \\ x^2 + y^2 + z^2 = 91, \\ y^2 = xz; \end{cases}$$

$$b) \begin{cases} \frac{xy}{x+y} = 1, \\ \frac{xz}{x+z} = 2, \\ \frac{yz}{y+z} = 3; \end{cases}$$

$$d) \begin{cases} x^2 + y^2 + z^2 = xy + yz + zx, \\ x^3 + y^3 + z^3 = 1; \end{cases}$$

$$e) \begin{cases} x + y + z = 0, \\ x^2 + y^2 + z^2 = 1, \\ x^3 + y^3 + z^3 = 0; \end{cases}$$

$$f) \begin{cases} x + y + z = 1, \\ x^2 + y^2 + z^2 = 1, \\ x^4 + y^4 + z^4 = 1; \end{cases}$$

$$g) \begin{cases} xy = 2, \\ yz = 3, \\ zx = 6. \end{cases}$$

6.391. Sistemani yeching:

$$a) \begin{cases} 2u + v = 7, \\ |u - v| = 2; \end{cases}$$

$$b) \begin{cases} y = x - 1 = 0, \\ ||y| - x - 1| = 0; \end{cases}$$

$$d) \begin{cases} 3u - v = 1, \\ |u - 2v| = 2; \end{cases}$$

$$e) \begin{cases} |x - 1| + y = 0, \\ 2x - y = 1; \end{cases}$$

$$f) \begin{cases} |x| + 2|y| = 3, \\ 5y + 7x = 2; \end{cases}$$

$$g) \begin{cases} y - 2|x| + 3 = 0, \\ ||y| + x - 3| = 0. \end{cases}$$

8. Determinant haqida tushuncha. Chiziqli tenglamalar sistemasini determinantlar yordamida yechish. *Determinant* – matematikaning muhim tushunchalaridan biri, biror qoida yoki qonuniyat bo'yicha tuzilgan ko'paytmalarning algebraik yig'indisidan iborat. Lotincha: *determinans (determinants)* – aniqlovchi. Masalan,

$$\begin{cases} a_1x + b_1y = c_1, \\ a_2x + b_2y = c_2 \end{cases}$$
 chiziqli tenglamalar sistemasini yechish talab

qilinsin. Birinchi tenglamani b_2 ga, ikkinchisini $-b_1$ ga ko'paytirib,

hadma-had qo'shamiz. Natijada: $x = \frac{c_1b_2 - c_2b_1}{a_1b_2 - a_2b_1}$. Shu kabi birinchi

tenglamani a_2 ga, ikkinchisini $-a_1$ ga ko'paytirib, hadma-had

qo'shsak: $y = \frac{c_2a_1 - c_1a_2}{a_1b_2 - a_2b_1}$. Sistemada noma'lumlar koeffitsiyentlarini

ularning yozilish tartibi bo'yicha parallel chiziqchalar yordamida

kvadrat shaklda $\begin{vmatrix} a_1 & b_1 \\ a_2 & b_2 \end{vmatrix}$ ko'rinishda yozsak, determinant hosil

bo'ladi. Uni D orqali belgilaylik. a_1, a_2, b_1, b_2 sonlari determinant

elementlari. Ular ikki satr va ikki ustunda joylashgan. Shunga ko'ra

determinant *ikkinchi tartibli* ($n=2$) deb ataladi. Uning qiymatini

topish uchun kvadratning a_1b_2 diagonalida joylashgan elementlari

ko'paytmasidan b_1a_2 diagonal elementlari ko'paytmasini ayirish

kerak. Koeffitsiyentlar va ozod hadlardan tuzilgan determinantlar

ham shu kabi hisoblanadi:

$$D = \begin{vmatrix} a_1 & b_1 \\ a_2 & b_2 \end{vmatrix} = a_1b_2 - b_1a_2,$$

$$D_x = \begin{vmatrix} c_1 & b_1 \\ c_2 & b_2 \end{vmatrix} = c_1b_2 - b_1c_2, \quad D_y = \begin{vmatrix} a_1 & c_1 \\ a_2 & c_2 \end{vmatrix} = a_1c_2 - c_1a_2.$$

$D = a_1b_2 - b_1a_2$ soni sistemaning asosiy determinanti, $D_x =$

$= c_1b_2 - b_1c_2$ va $D_y = a_1c_2 - c_1a_2$ sonlari esa sistemaning yordamchi

determinantlari deyiladi. D_x determinant D da x koeffitsiyentlari

ustunini va D_y determinant D da y koeffitsiyentlari ustunini ozod

hadlar ustuniga almashtirish orqali hosil qilinadi.

Agar $D = 0$ bo'lib, D_x va D_y lardan kamida bittasi noldan farqli bo'lsa, sistema yechimga ega bo'lmaydi. Agar $D = D_x = D_y = 0$ bo'lsa, sistema cheksiz ko'p yechimga ega bo'ladi.

Agar $D \neq 0$ bo'lsa, berilgan sistema yagona $(x; y)$ yechimga ega bo'ladi va bu yechim quyidagi formulalar bo'yicha topiladi:

$$x = \frac{D_x}{D}, y = \frac{D_y}{D}. \quad (1)$$

(1) formulalar *Kramer formulalari* deyiladi.

1- misol. $\begin{cases} -x + 6y = 3, \\ 2x - y = 5 \end{cases}$ sistemani yeching.

Yechish: $D = \begin{vmatrix} -1 & 6 \\ 2 & -1 \end{vmatrix} = (-1) \cdot (-1) - 6 \cdot 2 = -11,$

$$D_x = \begin{vmatrix} 3 & 6 \\ 5 & -1 \end{vmatrix} = -3 - 30 = -33, \quad D_y = \begin{vmatrix} -1 & 3 \\ 2 & 5 \end{vmatrix} = -5 - 6 = -11;$$

$$x = \frac{-33}{-11} = 3, \quad y = \frac{-11}{-11} = 1.$$

Bu usul uch va undan ortiq noma'lumli sistemalarni yechishda

ham qo'llaniladi. Masalan, $\begin{cases} a_1x + b_1y + c_1z = d_1, \\ a_2x + b_2y + c_2z = d_2, \\ a_3x + b_3y + c_3z = d_3 \end{cases}$ sistemaning

asosiy determinanti kvadrat shaklida, uchinchi ($n = 3$) tartibli, ya'ni uch satr va uch ustunga ega. Hisoblash yo'lini tushuntirish maqsadida uni quyidagi ko'rinishda yozamiz:

$$D = \begin{vmatrix} a_1 & b_1 & c_1 \\ a_2 & b_2 & c_2 \\ a_3 & b_3 & c_3 \end{vmatrix}$$

Strelkalar elementlarni ko'paytirish tartibini ko'rsatadi. Bunda chap-yuqoridan o'ng-u pastga yo'nalishdagi ko'paytmalar qo'shilib, o'ng yuqoridan chap-u pastga yo'nalishdagi ko'paytmalar yig'indisidan ayiriladi: $D = a_1b_2c_3 + b_1c_2a_3 + c_1a_2b_3 - b_1a_2c_3 - a_1c_2b_3 - c_1b_2a_3$. $n = 2$ holidagidek, D_x determinant D da a lar

ustunini, D_y determinant b lar ustunini, D_z determinant esa c lar ustunini d lar (ozod hadlar) ustuni bilan almashtirishdan hosil qilinadi:

$$D_x = \begin{vmatrix} d_1 & b_1 & c_1 \\ d_2 & b_2 & c_2 \\ d_3 & b_3 & c_3 \end{vmatrix}, \quad D_y = \begin{vmatrix} a_1 & d_1 & c_1 \\ a_2 & d_2 & c_2 \\ a_3 & d_3 & c_3 \end{vmatrix}, \quad D_z = \begin{vmatrix} a_1 & b_1 & d_1 \\ a_2 & b_2 & d_2 \\ a_3 & b_3 & d_3 \end{vmatrix}.$$

Natijada ushbu formulalar hosil bo'ladi:

$$x = \frac{D_x}{D}, \quad y = \frac{D_y}{D}, \quad z = \frac{D_z}{D}.$$

Determinantning ayrim xossalari:

1) *agar determinantning ustunlari satrlari bilan (va teskaricha) almashtirilsa, determinantning qiymati o'zgarmaydi.*

$$\text{Masalan, } \begin{vmatrix} 2 & 3 \\ 1 & 2 \end{vmatrix} = 2 \cdot 2 - 3 \cdot 1 = 1, \quad \begin{vmatrix} 2 & 1 \\ 3 & 2 \end{vmatrix} = 2 \cdot 2 - 1 \cdot 3 = 1;$$

2) *agar ikki satr (yoki ustun) elementlari bir xil yoki o'zaro proporsional, yoki biri ikkinchisining chiziqli kombinatsiyasidan iborat bo'lsa, bu determinant nolga teng bo'ladi.*

$$\text{Masalan, } \begin{vmatrix} 3 & 2 \\ 6 & 4 \end{vmatrix} = 3 \cdot 4 - 2 \cdot 6 = 0;$$

3) *biror satr (ustun) elementlarining umumiy ko'paytuvchisini determinant belgisidan tashqariga chiqarish mumkin.*

$$\text{Masalan, } \begin{vmatrix} 3 & 5 \\ 4 & 8 \end{vmatrix} = 4 \cdot \begin{vmatrix} 3 & 5 \\ 1 & 2 \end{vmatrix} = 4 \cdot (3 \cdot 2 - 5 \cdot 1) = 4 \cdot 1 = 4;$$

4) *bir satr elementlarini biror doimiy songa ko'paytirilib, ikkinchi satr elementlariga birma-bir qo'shilsa (... dan ayirilsa) determinant qiymati o'zgarmaydi.*

$$\text{Masalan, } \begin{vmatrix} 3 & 5 \\ 4 & 2 \end{vmatrix} = \begin{vmatrix} 3 & 5 \\ 4-3 & 2-5 \end{vmatrix} = 3 \cdot (-3) - 5 \cdot 1 = -14;$$

5) *agar n -tartibli (bu yerda $n \in \{2; 3\}$) determinantning biror k -satr elementlari m ta qo'shiluvchining yig'indisidan iborat bo'lsa, determinantni m ta n -tartibli determinant yig'indisi ko'rinishiga*

keltirish mumkin, bunda k -satr elementlari alohida qo'shiluvchilardan iborat bo'ladi.

$$\begin{vmatrix} a_1 & b_1 & c_1 \\ p_1 + q_1 & p_2 + q_2 & p_3 + q_3 \\ a_3 & b_3 & c_3 \end{vmatrix} = \begin{vmatrix} a_1 & b_1 & c_1 \\ p_1 & p_2 & p_3 \\ a_3 & b_3 & c_3 \end{vmatrix} + \begin{vmatrix} a_1 & b_1 & c_1 \\ q_1 & q_2 & q_3 \\ a_3 & b_3 & c_3 \end{vmatrix}.$$

Masalan, $\begin{vmatrix} 4 & 7 \\ 3 & 5 \end{vmatrix} = \begin{vmatrix} 2 & 4 \\ 3 & 5 \end{vmatrix} + \begin{vmatrix} 2 & 3 \\ 3 & 5 \end{vmatrix} = (2 \cdot 5 - 3 \cdot 4) + (2 \cdot 5 - 3 \cdot 3) =$
 $= -2 + 1 = -1.$

2-misol. $\begin{cases} 2x + 7y - 4z = -13, \\ 5x + 10y - z = -7, \\ 4x - 6y + z = 12 \end{cases}$ tenglamalar sistemasini

yeching.

Yechish. $D = \begin{vmatrix} 2 & 7 & -4 \\ 5 & 10 & -1 \\ 4 & -6 & 1 \end{vmatrix} = (3\text{-satrni } 2\text{-satrga qo'shamiz})$

$$\begin{vmatrix} 2 & 7 & -4 \\ 9 & 4 & 0 \\ 4 & -6 & 1 \end{vmatrix} = (3\text{-satrni } 4\text{ ga ko'paytirib, } 1\text{-satrqa qo'shamiz})$$

$$\begin{vmatrix} 18 & -17 & 0 \\ 9 & 4 & 0 \\ 4 & -6 & 1 \end{vmatrix} = 18 \cdot 4 \cdot 1 + (-17) \cdot |0| \cdot 4 + 0 \cdot 9 \cdot (-6) - 0 \cdot |4| -$$

$$-(-17) \cdot |9| \cdot 1 - 18 \cdot 0 \cdot (-6) = 225;$$

$$D_x = \begin{vmatrix} -13 & 7 & -4 \\ -7 & 10 & -1 \\ 12 & -6 & 1 \end{vmatrix} = \begin{vmatrix} 35 & -17 & 0 \\ 5 & 4 & 0 \\ 12 & -6 & 1 \end{vmatrix} = 35 \cdot 4 \cdot 1 +$$

$$+ (-17) \cdot 0 \cdot 12 + 0 \cdot 5 \cdot (-6) - 0 \cdot |4| \cdot 12 - (-17) \cdot 5 \cdot 1 -$$

$$-35 \cdot |0| \cdot (-6) = 140 + 0 + 0 - 0 + 85 - 0 = 225. \quad x = \frac{D_x}{D} = \frac{225}{225} = 1.$$

Shu kabi, $D_y = -225$, $D_z = 450$ va $y = -1$, $z = 2$ ni aniqlaymiz.



Mashqlar

6.392. Determinantlarni hisoblang:

a) $\begin{vmatrix} -3 & 0 \\ 7 & 5 \end{vmatrix};$

b) $\begin{vmatrix} 2 & -1 \\ 3 & 0 \end{vmatrix};$

d) $\begin{vmatrix} -5 & -7 \\ 13 & -6 \end{vmatrix};$

e) $\begin{vmatrix} 1 & -\frac{3}{2} \\ -2 & 3 \end{vmatrix};$

f) $\begin{vmatrix} 0 & 0 \\ 1 & -6 \end{vmatrix};$

g) $\begin{vmatrix} 1 & 0 \\ -3 & 0 \end{vmatrix};$

h) $\begin{vmatrix} 1-a & -a \\ a & 1+a \end{vmatrix};$

i) $\begin{vmatrix} x & 1 \\ x^2 & x^3 \end{vmatrix}.$

6.393. a ning qanday qiymatlarida determinantning satrlari proporsional bo'ladi:

a) $\begin{vmatrix} 1 & 3 \\ 2 & a \end{vmatrix};$

b) $\begin{vmatrix} a & -4 \\ 1 & 2 \end{vmatrix};$

d) $\begin{vmatrix} 7 & 5 \\ a & 3a \end{vmatrix};$

e) $\begin{vmatrix} 0 & 0 \\ 6 & a \end{vmatrix};$

6.394. Tenglamani yeching:

a) $\begin{vmatrix} a & 2 \\ 2 & a \end{vmatrix} = 0;$

b) $\begin{vmatrix} a-1 & 3 \\ a^2 & 3a \end{vmatrix} = 0;$

d) $\begin{vmatrix} a & a-1 \\ a+2 & a \end{vmatrix} = 0.$

6.395. Determinantlarni hisoblang:

a) $\begin{vmatrix} 2 & 3 & 4 \\ 5 & -2 & 1 \\ 1 & 2 & 3 \end{vmatrix};$

b) $\begin{vmatrix} 1 & 2 & 5 \\ 3 & -4 & 7 \\ -3 & 12 & -15 \end{vmatrix};$

d) $\begin{vmatrix} a & 1 & a \\ -1 & a & 1 \\ a & -1 & a \end{vmatrix};$

e) $\begin{vmatrix} 1 & b & 1 \\ 0 & b & 0 \\ b & 0 & b \end{vmatrix};$

f) $\begin{vmatrix} a & 1 & a \\ 0 & -a & -1 \\ a & 1 & -a \end{vmatrix};$

g) $\begin{vmatrix} a & -a & a \\ a & a & -a \\ a & -a & -a \end{vmatrix}.$

6.396. Tenglamani yeching:

$$\text{a) } \begin{vmatrix} x & 1 & 0 \\ 2 & 2 & 3 \\ 1 & 2 & x \end{vmatrix} = 0;$$

$$\text{b) } \begin{vmatrix} x^2 & 1 & 0 \\ 1 & 1 & 1 \\ 1 & 2 & 3 \end{vmatrix} = 0;$$

$$\text{d) } \begin{vmatrix} 1 & 2 & 3 \\ 1 & 2 & x \\ 1 & 2 & 4 \end{vmatrix} = 0;$$

$$\text{e) } \begin{vmatrix} 1 & 3 & 5 \\ 2 & 6 & 10 \\ x^4 & x & x \end{vmatrix} = 0.$$

6.397. Hisoblang:

$$\text{a) } 2 \cdot \begin{vmatrix} 1 & 3 \\ 2 & 5 \end{vmatrix} - 2 \cdot \begin{vmatrix} x & 2 \\ 1 & -1 \end{vmatrix}, \text{ bunda } x = 3,1(73);$$

$$\text{b) } 2, (7) \cdot \begin{vmatrix} x & 0 \\ 2 & 0 \end{vmatrix} + 3, (13), \text{ bunda } x = 2, (71).$$

6.398. Determinantlarni hisoblang:

$$\text{a) } \begin{vmatrix} 5 & 20 & 15 \\ 2 & 4 & 8 \\ 1 & 4 & 7 \end{vmatrix};$$

$$\text{b) } \begin{vmatrix} 1 & 0 & 0 \\ 6 & 2 & 0 \\ 5 & 4 & 3 \end{vmatrix};$$

$$\text{d) } \begin{vmatrix} 7 & 3 & 2 \\ 3 & 1 & 2 \\ 10 & 12 & 8 \end{vmatrix};$$

$$\text{e) } \begin{vmatrix} 1 & 3 & 2 \\ 2 & 1 & 2 \\ 4 & 12 & 8 \end{vmatrix};$$

$$\text{f) } \begin{vmatrix} 7 & 1 & 2 \\ 3 & 2 & 2 \\ 10 & 4 & 8 \end{vmatrix};$$

$$\text{g) } \begin{vmatrix} 7 & 3 & 1 \\ 3 & 1 & 2 \\ 10 & 12 & 4 \end{vmatrix}.$$

6.399. Tenglamani yeching:

$$\text{a) } 2 \cdot \begin{vmatrix} x & 1 \\ 2 & 3 \end{vmatrix} + 3 \cdot \begin{vmatrix} x & 1 & 0 \\ x^2 & x & 0 \\ 1 & 2 & 3 \end{vmatrix} = 0;$$

$$\text{b) } 2 \cdot \begin{vmatrix} x^2 & 1 & 0 \\ 1 & 1 & 0 \\ 3 & 4 & 1 \end{vmatrix} - 3 \cdot \begin{vmatrix} x & 3 \\ 2 & 4 \end{vmatrix} = 16;$$

$$\text{d) } \frac{\begin{vmatrix} x^2 & 1 & 0 \\ 1 & 1 & 0 \\ 3 & 4 & 1 \end{vmatrix}}{\begin{vmatrix} x & 3 \\ 2 & 4 \end{vmatrix}} - \frac{\begin{vmatrix} 4 & 2 \\ 3 & 6 \end{vmatrix}}{4x-6} = -\frac{67}{4}; \text{ e) } \frac{3}{\begin{vmatrix} 1 & 2 & 3 \\ 2 & 4 & 6 \\ 1 & 2 & 1 \end{vmatrix}} - x = 1.$$

6.400. Sistemaning asosiy determinantini hisoblang:

a) $\begin{cases} 3x + 4y = 7, \\ 2x - 5y = 1; \end{cases}$ b) $\begin{cases} 1,2x - 4y = 3, \\ 3x - 5y = 7; \end{cases}$

d) $\begin{cases} ax - y = 1, \\ 5x + 2y = 2; \end{cases}$ e) $\begin{cases} ax - by = 1, \\ 13x - 4y = 2. \end{cases}$

6.401. Sistemaning yordamchi determinantlarini hisoblang:

a) $\begin{cases} 2x - 3y = 1, \\ x - y - 7 = 0; \end{cases}$ b) $\begin{cases} 3x - 1,7y = 2, \\ 4x - 4,3y = 1; \end{cases}$

d) $\begin{cases} 3x - 5y = 2, \\ 4x + 3y = 5; \end{cases}$ e) $\begin{cases} 4x - 3y = 5, \\ 6x - 7y = 0. \end{cases}$

6.402. Sistemani Kramer formulalaridan foydalanib yeching:

a) $\begin{cases} 2x + 3y = -4, \\ 3x + 8y = 1; \end{cases}$ b) $\begin{cases} 2x + 11y = 15, \\ 10x - 11y = 9; \end{cases}$

d) $\begin{cases} 2x - 3y = -3, \\ x + 3y = 21; \end{cases}$ e) $\begin{cases} 2x - 3y = 16, \\ x + 2y = 1; \end{cases}$

f) $\begin{cases} x - 2y = 0, \\ 4x - 8y = 5; \end{cases}$ g) $\begin{cases} 2x - y = 3, \\ x - 0,5y = 1; \end{cases}$

h) $\begin{cases} -x + 3y = -2, \\ 2x - 6y = -1; \end{cases}$ i) $\begin{cases} \frac{3}{4}x - \frac{5}{7}y = \frac{23}{168}, \\ 2x + 6y = \frac{31}{165}; \end{cases}$

j) $\begin{cases} x - y = 1, \\ 3y - 3x = -3; \end{cases}$ k) $\begin{cases} 3x - 5y = 0, \\ -15x + 25y = 0; \end{cases}$

l) $\begin{cases} 2x - 3y = -1, \\ 4x - 6y = 1; \end{cases}$ m) $\begin{cases} 7x - 2y = 16, \\ 3,5x - y = 8. \end{cases}$

6.403. $\begin{cases} 3x - 5y = -7, \\ 4x + 7y = 18 \end{cases}$ sistema berilgan:

- 1) sistemaning har bir tenglamasi nechta yechimga ega?
 2) sistema nechta yechimga ega?

6.404. Sistemani Kramer formulalari yordamida yeching:

$$a) \begin{cases} -x_1 + 2x_2 + 3x_3 = 0, \\ x_1 - 4x_2 - 13x_3 = 0, \\ -3x_1 + 5x_2 + 4x_3 = 0; \end{cases}$$

$$b) \begin{cases} 2x - 4y + z = 1, \\ x - 2y + 4z = 3, \\ 3x - y + 5z = 2; \end{cases}$$

$$d) \begin{cases} x + 2y + 3z = 1, \\ 2x + y - z = 3, \\ 3x + 3y + 2z = 10; \end{cases}$$

$$e) \begin{cases} x + 2y + 3z = 4, \\ 2x + 4y + 6z = 3, \\ 3x + y - z = 1; \end{cases}$$

$$f) \begin{cases} 2x - 3y + z - 2 = 0, \\ x + 5y - 4z + 5 = 0, \\ 4x + y - 3z = -4; \end{cases}$$

$$g) \begin{cases} 7x + 3y + 2z = 1, \\ 3x + y + 2z = 2, \\ 10x + 12y + 8z = 4. \end{cases}$$

6.405. $\begin{cases} a^2x - ay = a - 1, \\ bx + (3 - 2b)y = 3 + a \end{cases}$ sistema (1; 1) dan iborat yagona yechimga ega. a va b larni toping.

6.406. a va b larning quyidagi sistema cheksiz ko'p yechimga ega bo'ladigan barcha qiymatlarini toping:

$$\begin{cases} a^2x - by = a^2 - b, \\ bx - b^2y = 2 + 4a. \end{cases}$$

6.407. a ning qanday qiymatlarida

$$\begin{cases} ax - 4y = a + 1, \\ 2x + (a + 6)y = a + 3 \end{cases}$$

sistema yechimga ega bo'lmaydi?

6.408. a ning qanday qiymatlarida

$$\begin{cases} 2x - ay = a + 2, \\ (a + 1)x + 2ay = 2a + 4 \end{cases}$$

sistema cheksiz ko'p yechimga ega bo'ladi?

6.409. Sistemani yeching:

$$\begin{array}{ll} \text{a)} \begin{cases} 5x + 2y + 3z = -7, \\ 5x + 2y + 3z = 4; \end{cases} & \text{b)} \begin{cases} 5x - 3y = 7, \\ -2x + 9y = 4, \\ 2x + 2y = -2; \end{cases} \\ \text{d)} \begin{cases} 4x + 5z = 6, \\ y - 6z = -2; \end{cases} & \text{e)} \begin{cases} x + 2y = 3, \\ 3y - 2z = -1. \end{cases} \end{array}$$

6.410. a ning $\begin{cases} 2x + 2(a-1)y = a-4, \\ 2|x+1| = ay+2 \end{cases}$ sistema yagona yechimga

ega bo'ladigan barcha qiymatlarini toping. Sistemaning yechimini toping.

6.411. a ning $\begin{cases} ax + (a-1)y = 2 + 4a, \\ 3|x| + 2y = a-5 \end{cases}$ sistema yagona yechimga

ega bo'ladigan barcha qiymatlarini toping. Sistemaning yechimini toping.

5- §. Tenglamalar tuzishga doir masalalar

1- m a s a l a . Ikki ishchi birga ishlab smena davomida 72 ta detal tayyorladi. Ishlab chiqarish unumdorligini birinchi ishchi 15% ga, ikkinchi ishchi esa 25% ga oshirgach, ular smena davomida birgalikda 86 ta detal tayyorlay boshlashdi. Mehnat unumdorligi oshgach, har bir ishchi smena davomida nechtdan detal tayyorlagan?

Y e c h i s h . Mehnat unumdorligini oshirgunga qadar birinchi ishchi smena mobaynida x ta detal, ikkinchi ishchi esa y ta detal tayyorlagan bo'lsin. U holda mehnat unumdorligi oshgandan so'ng, birinchi ishchi $x + 0,15x$ ta detal, ikkinchi ishchi esa $y + 0,25y$ ta detal tayyorlay boshlagan.

Quyidagi sistemaga egamiz: $\begin{cases} x + y = 72, \\ 1,15x + 1,25y = 86. \end{cases}$ Bundan

$x = 40, y = 32$ larni topamiz. Mehnat unumdorligi oshgach, birinchi

ishchi smena mobaynida $1,15x = 1,15 \cdot 40 = 46$ ta, ikkinchi ishchi esa $1,25y = 1,25 \cdot 32 = 40$ ta detal tayyorlagan.

J a v o b : 46 ta va 40 ta.

2- m a s a l a . Ikki sonning yug'indisi 60 ga, nisbati esa 4 ga teng. Shu sonlarni toping.

Y e c h i s h . x va y izlangan sonlar bo'lib, $x > y$ bo'lsin. Quyidagi sistemaga egamiz:

$$\begin{cases} x + y = 60, \\ x : y = 4. \end{cases}$$

Bu sistemadan, $x = 48$, $y = 12$ ni topamiz.

J a v o b : 48 va 12.

3- m a s a l a . Ikki ishchining ikkinchisi birinчисidan $1\frac{1}{2}$ kun keyin ishga tushsa, ular birgalikda bir ishni 7 kunda tamomlay oladilar. Agar bu ishni har qaysi ishchi yolg'iz o'zi bajarsa, u holda birinchi ishchi ikkinchi ishchiga qaraganda 3 kun ortiq ishlashi kerak bo'ladi. Har qaysi ishchining yolg'iz o'zi bu ishni necha kunda tamomlay oladi?

Y e c h i s h . Birinchi ishchi yolg'iz o'zi ishlab ishni x kunda, ikkinchi ishchi esa yolg'iz o'zi ishlab y kunda bajarsin. U holda birinchi ishchi bir kunda ishning $\frac{1}{x}$ qismini, ikkinchi ishchi bir kunda ishning $\frac{1}{y}$ qismini bajaradi.

Birinchi ishchi $1\frac{1}{2}$ kun ishlab, ishning $1\frac{1}{2} \cdot \frac{1}{x} = \frac{3}{2x}$ qismini bajargach, ikkinchi ishchi ishlashni boshladi. Ular birgalikda 7 kun ishlagan. Shu 7 kunda ishning $7 \cdot \frac{1}{x} + 7 \cdot \frac{1}{y} = \frac{7x+7y}{xy}$ qismi

bajarilgan. $\frac{3}{2x} + \frac{7x+7y}{xy} = 1$ tenglamaga ega bo'lamiz. Yolg'iz o'zi ishlagan birinchi ishchi ikkinчисiga qaraganda 3 kun ko'p ishlab, ishni tamomlaydi. Demak, $x - 3 = y$.

$$\begin{cases} \frac{3}{2x} + \frac{7x+7y}{xy} = 1, \\ x - 3 = y \end{cases} \text{ sistemani hosil qilamiz. Bu sistemani}$$

yechsak, $x = 17$, $y = 14$ bo'ladi.

Javob: Birinchi ishchi 17 kunda, ikkinchi ishchi 14 kunda.

4- masala. Oltin va kumushdan qilingan ikki xil qotishmalarning birinchisida oltin va kumush 2 : 3 nisbatda, ikkinchisida esa 3 : 7 nisbatda ekanligi ma'lum. Oltin va kumush 5 : 11 nisbatda bo'ladigan yangi qotishma hosil qilish uchun ko'rsatilgan metallarni qanday nisbatda olish kerak?

Yechish. Birinchi qotishmaning $\frac{2}{2+3} = \frac{2}{5}$ qismi oltin va

$\frac{3}{2+3} = \frac{3}{5}$ qismi kumushdan iborat. Ikkinchi qotishmaning

$\frac{3}{3+7} = \frac{3}{10}$ qismi oltin va $\frac{7}{3+7} = \frac{7}{10}$ qismi esa kumushdir.

Yangi qotishma hosil qilish uchun olingan birinchi qotishmaning miqdorini x bilan va ikkinchi qotishmaning miqdorini y bilan belgilaylik (x va y lar og'irlikni ifodalaydi).

x miqdordagi birinchi qotishmadagi oltinning va kumushning

miqdori mos ravishda $\frac{2}{5}x$ va $\frac{3}{5}x$ ga teng. y miqdordagi ikkinchi

qotishmadagi oltinning miqdori $\frac{3}{10}y$ ga, kumushning miqdori

esa $\frac{7}{10}y$ ga teng. Yangi qotishmaga $\frac{2}{5}x + \frac{3}{10}y$ miqdorda oltin va

$\frac{3}{5}x + \frac{7}{10}y$ miqdorda kumush kiradi. Shartga ko'ra,

$$\frac{\frac{2}{5}x + \frac{3}{10}y}{\frac{3}{5}x + \frac{7}{10}y} = \frac{5}{11}. \text{ Bu tenglikdan } \frac{x}{y} \text{ nisbatni topamiz:}$$

$$\frac{4x+3y}{6x+7y} = \frac{5}{11} \Rightarrow 44x + 33y = 30x + 35y \Rightarrow 14x = 2y \Rightarrow \frac{x}{y} = \frac{1}{7}.$$

Javob: Qotishmalarni 1 : 7 nisbatda olish kerak.

5 - masala. Mahsulot dastlab 20 % ga arzonlashtirildi. Yangi narx yana 10 % kamaytirilgach, hosil bo'lgan keyingi narx yana 5 % ga kamaytirildi. Mahsulotning dastlabki narxi necha foiz kamaytirildi?

Yechish. Mahsulotning dastlabki narxi x (so'm) bo'lsin. Bu narx 20 % kamaytirilgach, mahsulotning narxi $x - 0,20x = 0,80x$ (so'm) bo'ladi. Bu narx 10 % kamaytirilsa, $0,80x - 0,10 \times 0,80x = 0,72x$ so'mdan iborat bo'lgan yangi narx paydo bo'ladi. Bu narx 5 % kamaytirilsa, mahsulotning oxirgi narxi $0,72x - 0,05 \cdot 0,72x = 0,684x$ so'm ekanligi kelib chiqadi.

Dastlabki narx x so'm, eng oxirgi narx $0,684x$ so'm bo'ldi. Mahsulot $x - 0,684x = 0,316x$ so'mga arzonlashtirildi. $0,316x$ so'm x so'mning necha foizini tashkil etishini topamiz.

Proporsiya tuzamiz: $\frac{x}{0,316x} = \frac{100}{p}$. Bundan, $p = 31,6$ ekani

kelib chiqadi.

Javob: 31,6 %.

6 - masala. Ikki xonali noma'lum son raqamlarining yig'indisi 12 ga teng. Shu ikki xonali noma'lum songa 36 soni qo'shilsa, noma'lum sonning raqamlarini teskari tartibda yozishdan hosil bo'ladigan son kelib chiqadi. Noma'lum sonni toping.

Yechish. Ikki xonali noma'lum sonning raqamlari x, y bo'lsin, ya'ni $\overline{xy} = 10x + y$ izlangan son bo'lsin. Quyidagiga egamiz:

$$\begin{cases} x + y = 12, \\ \overline{xy} + 36 = \overline{yx} \end{cases} \text{ yoki } \begin{cases} x + y = 12, \\ 10x + y + 36 = 10y + x. \end{cases} \text{ Bu sistemadan}$$

$x = 4, y = 8$ ekani kelib chiqadi. Demak, izlanayotgan son 48 ekan.

Javob: 48.

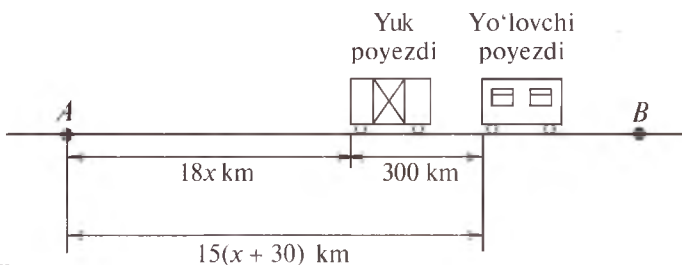

29- rasm.

7-masala. Yuk poyezdi A shahardan B shaharga qarab jo'nadi. Oradan 3 soat o'tgach, A shahardan B shaharga qarab, yo'lovchi poyezdi yo'lga chiqdi va oradan 15 soat o'tgach, yuk poyezdidan 300 km o'zib ketdi. Agar yo'lovchi poyezdining tezligi yuk poyezdining tezligidan 30 km/soat ortiq bo'lsa, yuk poyezdining tezligini toping (29- rasm).

Yechish. Yuk poyezdining tezligi x km/soat bo'lsin. U holda yo'lovchi poyezdining tezligi $(x + 30)$ km/soat bo'ladi. Yo'lovchi poyezdi 15 soat yurib, $15(x + 30)$ km masofani bosib o'tadi. Yuk poyezdi 18 soatda $18x$ km masofani bosib o'tgan.

$18x + 300 = 15(x + 30)$ tenglamaga ega bo'lamiz. Undan $x = 50$ ekani aniqlanadi.

Javob: 50 km/soat.

8-masala. A va D nuqtalar orasidagi masofa 75 km. Velosipedchi A nuqtadan D nuqtaga borishda AB masofani 20 km/soat, BC masofani 10 km/soat, CD masofani 5 km/soat tezlik bilan 7 soatda, qaytishda esa DC masofani 15 km/soat, CB masofani 12 km/soat, BA masofani 10 km/soat tezlik bilan 6 soat 15 minutda o'tgan. AB , BC , CD masofalarni toping.

Yechish. $AB = x$, $BC = y$, $CD = z$ bo'lsin (30- rasm).

Masala tahlilini jadval orqali ifodalaymiz:

1) borish:

	AB	BC	CD
masofa, km	x	y	z
tezlik, km/soat	20	10	5
vaqt, soat	$x/20$	$y/10$	$z/5$

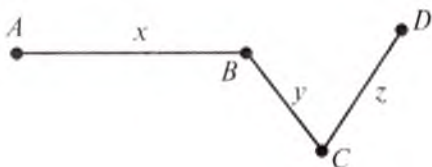

30- rasm.

2) qaytish:

	<i>DC</i>	<i>CB</i>	<i>BA</i>
masofa, km	<i>z</i>	<i>y</i>	<i>x</i>
tezlik, km/soat	15	12	10
vaqt, soat	$z/15$	$y/12$	$x/10$

Tenglamalar sistemasini tuzamiz:

$$\begin{cases} x + y + z = 75, \\ \frac{x}{20} + \frac{y}{10} + \frac{z}{5} = 7, \\ \frac{x}{10} + \frac{y}{12} + \frac{z}{15} = 6\frac{2}{3} \end{cases} \Rightarrow \begin{cases} x + y + z = 75, \\ x + 2y + 4z = 140, \\ 6x + 5y + 4z = 400. \end{cases}$$

Bu sistemadan, $x = 40$, $y = 20$, $z = 15$ larni topamiz.

Javob: $AB = 40$ km, $BC = 20$ km, $CD = 15$ km.



Mashqlar

- 6.412.** To'g'ri to'rtburchakning balandligi asosining 75 % iga teng. Agar shu to'g'ri to'rtburchakning yuzi 48 m² bo'lsa, uning perimetrini toping.
- 6.413.** 15 t sabzavotni tashish uchun ma'lum miqdorda yuk ortadigan bir necha mashina so'ralgan edi. Garajda tayyor turgan mashinalar bo'lmagani uchun, garaj so'ralgandan bitta ortiq, lekin 0,5 t kam yuk ortadigan mashinalar yubordi. Yuborilgan mashinalarning har biriga necha tonnadan sabzavot ortilgan?

- 6.414.** Xo'jalik 200 ga yerga ma'lum muddatda chigit ekib bo'lishi kerak edi, ammo u har kuni rejadagidan 5 ga ortiq chigit ekib, ishni muddatidan 2 kun oldin tugatdi. Chigit ekishi necha kunda tugallangan?
- 6.415.** Tomosha zalida 320 ta o'rin bor edi. Har bir qatordagi o'rinlar soni 4 ta orttirilib, yana bir qator qo'shilgandan so'ng 420 ta joy bo'ldi. Tomosha zalidagi joylar endi necha qator bo'ldi?
- 6.416.** Kema oqimga qarshi 48 km va oqim bo'yicha ham shuncha yo'l bosdi, hamma yo'lga 5 soat vaqt sarf qildi. Daryo oqimining tezligi 4 km/soat bo'lsa, kemaning turg'un suvdagi tezligini toping.
- 6.417.** Ikki pristan orasidagi masofa daryo yo'li bilan 80 km. Kema shu pristanlarning biridan ikkinchisiga borib-kelish uchun 8 soat 20 minut vaqt sarf qildi. Daryo oqimining tezligi 4 km/soat bo'lsa, kemaning turg'un suvdagi tezligini toping.
- 6.418.** Qayiq daryo oqimiga qarshi 22,5 km, oqim bo'yicha esa 28,5 km yurib, butun yo'lga 8 soat vaqt sarfladi. Oqimning tezligi 2,5 km/soat. Qayiqning turg'un suvdagi tezligini toping.
- 6.419.** Daryo yoqasidagi qishloqdan sol oqizildi. Oradan 5 soat 20 minut o'tgach, o'sha qishloqdan motorli qayiq jo'natildi. Motorli qayiq 20 km yo'l bosib, solga yetib oldi. Agar motorli qayiqning tezligi solning tezligidan 12 km/soat ortiq bo'lsa, solning tezligini toping.
- 6.420.** Suv ikkita quvurdan kelganda suv haydash qozoni 2 soat 55 minutda to'ladi. Birinchi quvurning yolg'iz o'zi suv haydash qozonini ikkinchisiga qaraganda 2 soat oldin to'ldira oladi. Har qaysi quvurning yolg'iz o'zi suv haydash qozonini qancha vaqtda to'ldiradi?
- 6.421.** Ikki ishchi ayni bir ishni birgalashib ishlasa, 12 kunda tamom qiladi. Agar oldin bittasi ishlab, ishning yarmini tamom qilgandan keyin uning o'rniga ikkinchisi ishlasa,

ish 25 kunda tamom bo'ladi. Shu ishni har qaysi ishchi yolg'iz o'zi ishlasa, necha kunda tamom qiladi?

6.422. Quvvatlari har xil ikkita traktor 4 kun birga ishlab jamoa xo'jaligi yerining $\frac{2}{3}$ qismini haydadi. Agar butun yerni birinchi traktor ikkinchisiga qaraganda 5 kun tezroq hayday olsa, butun yerni har qaysi traktor yolg'iz o'zi necha kunda hayday oladi?

6.423. Bandargohdagi ikki kema bir vaqtda, biri shimolga qarab, ikkinchisi sharqqa qarab jo'nadi. 2 soatdan keyin ular orasidagi masofa 60 km bo'ldi. Bu kemalardan birining tezligi ikkinchisidan 6 km/soat ortiq. Har qaysi kemaning tezligini toping.

6.424. Har qanday uchtasi bir to'g'ri chiziqda yotmaydigan 7 ta nuqtadan nechta turli to'g'ri chiziq o'tkazish mumkin?

Yechish. 31-rasmga qarang. Boshi A_1 nuqtada bo'lgan 6 ta vektorga egamiz. Boshi qolgan nuqtalarda bo'lgan vektorlar ham 6 tadan bo'ladi. Hammasi bo'lib $7 \cdot 6 = 42$ ta turli vektorlar hosil bo'ladi. Bu vektorlar 21 juft qarama-qarshi vektorlardir. Qarama-qarshi vektorlar jufti bitta to'g'ri chiziqda yotadi (bizning misolda).

Shunday qilib, aytilgan to'g'ri chiziq 42 : 2 = 21 ta ekan. Topshiriq. Har qanday uchtasi bir to'g'ri chiziqda yotmaydigan n ta nuqta orqali o'tuvchi turli to'g'ri

chiziq soni $\frac{n(n-1)}{2}$ ga tengligini isbotlang. Bu tasdiqdan foydalanib, [6.425–6.429] masalalarni yeching.

6.425. Futbol o'yini musobaqasida hammasi bo'lib 55 ta o'yin o'ynaldi. Bunda har bir komanda qolgan komandalar bilan faqat bir martadan o'ynadi. Musobaqada nechta komanda qatnashgan?

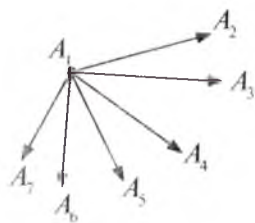

6.426. Shaxmat turnirida hammasi bo'lib 231 partiya shaxmat o'ynaldi. Agar har bir shaxmatchi qolgan shaxmat-

31-rasm.

chilarning har biri bilan faqat bir partiya shaxmat o'ynagan bo'lsa, turnirda necha kishi qatnashgan?

- 6.427.** Maktab bitiruvchilari bir-birlari bilan rasm almashtirishdi. Agar 870 ta rasm almashtirilgan bo'lsa, maktabni necha o'quvchi bitirgan?
- 6.428.** Qavariq ko'pburchakning 14 ta diagonali mavjud. Uning tomonlari nechta?
- 6.429.** Qanday ko'pburchak diagonallarining soni tomonlarining sonidan 12 ta ortiq bo'ladi?
- 6.430.** Poyezd yo'lda 6 minut to'xtab qoldi va 20 km yo'lda tezligini soatiga jadvaldagidan 10 km oshirib, kechikishni yo'qotdi. Poyezd shu yo'lda jadvalga muvofiq qanday tezlik bilan yurishi kerak edi?
- 6.431.** *A* va *B* stansiyalar orasidagi yo'lning o'rtasida poyezd 10 minut to'xtab qoldi. *B* stansiyaga kechikmasdan borish uchun, haydovchi poyezdning dastlabki tezligini 6 km/soat oshirdi. Agar stansiyalar orasidagi masofa 60 km bo'lsa, poyezdning dastlabki tezligini toping.
- 6.432.** Perimetri 28 sm bo'lgan to'g'ri to'rtburchakning qo'shni tomonlariga tashqaridan yasalgan kvadratlar yuzlarining yig'indisi 116 sm^2 ga teng. To'g'ri to'rtburchakning tomonlarini toping.
- 6.433.** Yuzi 120 sm^2 , diagonali esa 17 sm bo'lgan to'g'ri to'rtburchakning tomonlarini toping.
- 6.434.** To'g'ri burchakli uchburchakning gipotenuzasi 41 sm, yuzi 180 sm^2 . Katetlarni toping.
- 6.435.** To'g'ri burchakli uchburchakning perimetri 48 sm, yuzi 96 sm^2 . Uchburchakning tomonlarini toping.
- 6.436.** Ikki musbat sonning o'rta arifmetigi 20, o'rta geometrigi esa 12. Shu sonlarni toping.
- 6.437.** Ikki shahar orasidagi masofa 480 km; shu masofani yo'lovchi poyezdi yuk poyezdiga qaraganda 4 soat tez bosadi. Agar yo'lovchi poyezdining tezligi 8 km/soat oshirilsa, yuk poyezdining tezligi esa 2 km/soat oshirilsa, yo'lovchi poyezdi shu masofani yuk poyezdiga qara-

ganda 5 soat tez o'tadi. Har qaysi poyezdning tezligini toping.

- 6.438.** Oralaridagi masofa 180 km bo'lgan A va B shaharlardan ikki poyezd bir vaqtda bir-biriga qarab yo'lga chiqdi. Ular uchrashgandan keyin A shahardan chiqqan poyezd B shaharga 2 soatda yetib boradi, ikkinchisi esa A shaharga 4,5 soatda yetib boradi. Poyezdlar tezligini toping.
- 6.439.** Velosipedchilar poygasi uchun 6 km uzunlikdagi masofa belgilandi. Akmal Shavkatdan o'tib ketib, marraga 2 minut oldin keldi. Agar Akmal tezligini 0,1 km/minut kamaytirib, Shavkat tezligini 0,1 km/minutga oshirsa, unda Akmal marraga Shavkatdan 2 minut oldin yetib kelardi. Akmal va Shavkatlarning tezligini toping.
- 6.440.** Ikki ekskavatorchi birga ishlab, biror hajmdagi yer ishlarini 3 soat-u 45 minutda bajaradi. Bir ekskavatorchi alohida ishlab, bu hajmdagi ishni ikkinchisiga qaraganda 4 soat tezroq bajaradi. Shunday hajmdagi yer ishlarini bajarish uchun har bir ekskavatorchiga alohida qancha vaqt kerak bo'ladi?
- 6.441.** Bir kombaynchi maydondagi bug'doy hosilini ikkinchi kombaynchidan 24 soat tezroq o'rib olishi mumkin. Ikkala kombaynchi birgalikda ishlaganda esa hosilni 35 soatda yig'ib olishadi. Har bir kombaynchi alohida ishlab, hosilni o'rib olishi uchun qancha vaqt kerak bo'ladi?
- 6.442.** Ikkita musbat sonning yig'indisi ularning ayirmasidan 5 marta katta. Agar shu sonlar kvadratlari ayirmasi 180 ga teng bo'lsa, bu sonlarni toping.

6- §. Tengsizliklar sistemasi

1. Bir o'zgaruvchili ratsional tengsizliklar sistemasi va majmuasi. Bir o'zgaruvchili $P_1(x) \wedge_1 0, P_2(x) \wedge_2 0, \dots, P_n(x) \wedge_n 0$ ratsional tengsizliklarni qaraymiz.

Bu yerda \wedge_1 tengsizlik belgisi bo'lib, uning o'rnida

$$<, >, \leq, \geq \quad (*)$$

tengsizliklar majmuasining yechimi deyiladi. Yuqorida keltirilgan tengsizliklarning majmuasi quyidagicha belgilanadi:

$$\begin{cases} P_1(x) \wedge_1 0 \\ P_2(x) \wedge_2 0 \\ \dots\dots\dots \\ P_3(x) \wedge_3 0 \end{cases} \quad (2)$$

(2) majmuani yechish uning barcha yechimlarini topish yoki ularning mavjud emasligini isbotlash demakdir. Tengsizliklar majmuasini yechish uchun odatda har bir tengsizlik alohida yechilib, yechimlar to'plamlari hosil qilinadi va shu to'plamlarning birlashmasi topiladi.

2 - m i s o l. $x = 1$ soni quyidagi majmuaning yechimi bo'lishini isbotlang va majmuani yeching:

$$\begin{cases} 2x + 7 > 9 - x, \\ 4x + 9 < 3x + 5. \end{cases}$$

Y e c h i s h. $x = 1$ soni majmuadagi $2x + 7 > 9 - x$ tengsizlikning yechimi bo'ladi. Demak, u majmuaning ham yechimidir. Berilgan majmuani yechamiz:

$$\begin{array}{l|l} 2x + 7 > 9 - x & 4x + 9 < 3x + 5 \\ 2x + x > 9 - 7 & 4x - 3x < 5 - 9 \\ 3x > 2 & x < -4 \\ x > \frac{2}{3} & \end{array}$$



$(-\infty; -4)$ va $(\frac{2}{3}; +\infty)$ to'plamlarning birlashmasi $(-\infty; -4) \cup (\frac{2}{3}; +\infty)$ majmuaning barcha yechimlari to'plamidir.



Mashqlar

6.443. Tengsizliklar sistemasini yeching. So'ngra bu sistemalarning har birini majmuaga aylantiring va majmualarni yeching:

$$a) \begin{cases} (2x+3)(2x+1)(x-1) < 0, \\ (x+5)(x+1)(1-2x)(x-3) > 0; \end{cases}$$

$$b) \begin{cases} (x^2+12x+35)(2x+1)(3-x) \geq 0, \\ (x^2-2x-8)(2x-1) \geq 0; \end{cases}$$

$$d) \begin{cases} \frac{x+3}{3-x} < 2, \\ x^3 < 16x, \\ 4 \geq x^2; \end{cases}$$

$$e) \begin{cases} \frac{(x+2)(x^3-3x+8)}{x^2-9} \leq 0, \\ \frac{1-x^2}{x^2+2x-8} \geq 0. \end{cases}$$

2. Ikki o'zgaruvchili tengsizliklar. Har qanday $y=f(x)$ chiziq unda yotgan nuqtalarning to'plamini – shu chiziqni, $y > f(x)$ tengsizlik koordinata tekisligining chiziqdan yuqorida joylashgan, $y < f(x)$ tengsizlik esa chiziqdan pastda joylashgan qismini ifodalaydi. Agar bu qismlarga chiziqning o'zi ham qo'shilsa, uni $y \leq f(x)$ yoki $y \geq f(x)$ tengsizliklar ifodalaydigan bo'ladi. Aksincha, $f(x) \leq a$ yoki $f(x) \geq a$ tengsizlikning yechimini tekislikning ularga mos qismlari sohalari beradi. Shu kabi $f(x) < g(x)$ tengsizligining yechimini tekislikning $f(x)$ chiziqdan yuqori va $g(x)$ chiziqdan pastda yotgan qismlari kesishmasi beradi:

$$\begin{cases} y \geq f(x), \\ y \leq g(x). \end{cases}$$

Ko'pincha sistemani

$$\begin{cases} a \leq x \leq b, \\ f(x) \leq y \leq g(x) \end{cases} \quad (1)$$

yoki

$$\begin{cases} c \leq y \leq d, \\ f(y) \leq x \leq g(y) \end{cases} \quad (2)$$

ko'rinishda yozish qulay.

1-misol. $\begin{cases} y \geq x^2, \\ y \leq x+2 \end{cases}$ tengsizliklar sistemasi bilan berilgan

sohani (1) ko'rinishga keltiramiz.

Yechish. Oldin $y = x + 2$ to'g'ri chiziq va $y = x^2$ parabolaning kesishish nuqtalarini topamiz. Buning uchun

$$\begin{cases} y = x + 2, \\ y = x^2 \end{cases}$$

tenglamalar sistemasini yechamiz. Uning yechimi $(-1; 1)$, $(2; 4)$. Izlanayotgan sohani (1) sistema ko'rinishida yozamiz:

$$\begin{cases} -1 \leq x \leq 2, \\ x^2 \leq y \leq x + 2. \end{cases}$$

2- misol. Radiusi $R = 4$, markazi $A(-1; 2)$ nuqta bo'lgan aylana ichki qismini (1) tengsizliklar sistemasini ko'rinishida ifodalang.

Yechish. Aylana tenglamasi: $(x + 1)^2 + (y - 2)^2 = 16$. Bundan pastki va yuqorigi yarim aylanalarning tenglamalarini topamiz:

$$y = 2 - \sqrt{16 - (x + 1)^2}, \quad y = 2 + \sqrt{16 - (x + 1)^2}.$$

Argument $a = -1 - 4 = -5$ dan $b = -1 + 4 = 3$ gacha o'zgaradi. Izlanayotgan sistema:

$$\begin{cases} -5 \leq x \leq 3, \\ 2 - \sqrt{16 - (x + 1)^2} \leq y \leq 2 + \sqrt{16 - (x + 1)^2} \end{cases}$$

dan iborat.

3- misol. 32- rasmda tasvirlangan parabola va to'g'ri chiziqning kesishuvidan hosil bo'ladigan yopiq shaklni ifodalovchi tengsizliklar sistemasini tuzamiz.

Yechish. Parabola $(0; 0)$, $(2; 0)$, $(1; 10)$ nuqtalar ustidan o'tadi. Uning $y = Ax^2 + Bx + C$ tenglamasini tuzish uchun A , B , C parametrlarini topamiz. Buning uchun uch noma'lumli uch tenglama sistemasini tuzamiz va undan A , B , C larni aniqlaymiz.

$(0; 0)$ nuqta bo'yicha: $0 = A \cdot 0^2 + B \cdot 0 + C$, bundan $C = 0$;

$(2; 0)$ nuqta bo'yicha: $0 = A \cdot 2^2 + B \cdot 2 + C$, bundan $2A + B = 0$;

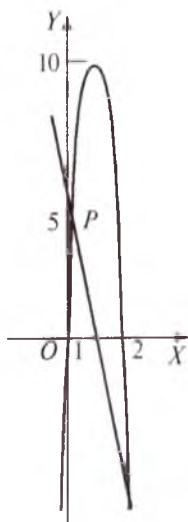

32- rasm.

(1; 10) nuqta bo'yicha: $10 = A \cdot 1^2 + B \cdot 1 + C$, bundan $A + B = 10$.

Keyingi ikki tenglamalar sistemasidan $A = -10$, $B = 20$ aniqlanadi.

Parabolaning tenglamasi: $y = -10x^2 + 20x$. To'g'ri chiziq (0; 5), (1; 0) nuqtalardan o'tadi. Tenglamasi: $y = -4x + 5$. Kesishuvdan hosil bo'luvchi yopiq shakl paraboldan pastda, to'g'ri chiziqdan yuqorida joylashgan. Shunga ko'ra

$$\begin{cases} y \geq -4x + 5, \\ y \leq -10x^2 + 20x. \end{cases}$$



Mashqlar

6.444. Tengsizliklar sistemalari bilan berilgan sohalarni chizing:

a) $\begin{cases} -5 \leq x \leq 2, \\ x^2 - 9 \leq y \leq 1 - 2x; \end{cases}$

b) $\begin{cases} -1 \leq y \leq 3, \\ y - 1 \leq x \leq 8 - y; \end{cases}$

d) $\begin{cases} -2 \leq x \leq 2, \\ x^2 - 2 \leq y \leq x + 6; \end{cases}$

e) $\begin{cases} -3 \leq x \leq 4, \\ 0 \leq y \leq \sqrt{16 - x^2}. \end{cases}$

6.445. Tengsizliklar bilan ifodalang:

a) uchlari $O(0; 0)$, $A(2; 0)$, $B(2; 2)$, $C(0; 1)$ nuqtalar bo'lgan to'rtburchakni;

b) uchlari $A(1; 3)$, $B(2; 6)$, $C(10; 6)$ nuqtalar bo'lgan uchburchakni;

d) markazi $M(1; 1)$ nuqtada va yoyining uchlari $A(\sqrt{5}; 2)$ va $B(-\sqrt{5}; 20)$ nuqtalarda bo'lgan AOB doiraviy sektorni;

e) AOB parabola yoyi va $A(-1; 8)$ va $B(1; 8)$ nuqtalarni tutashtiruvchi vatar bilan chegaralangan AOB parabola segmentini, bunda $O(0; 0)$.

6.446. D soha tengsizlik bilan yoki tengsizliklar sistemasi bilan berilgan. Uni (1) ko'rinishdagi tengsizliklar sistemasi bilan bering:

$$\text{a) } x \geq 0, y \leq 0, x - 4 \geq y, \text{ ya'ni } \begin{cases} x \geq 0, \\ y \leq 0, \\ x - 4 \geq y; \end{cases}$$

$$\text{b) } 4x^2 + y^2 \leq a;$$

$$\text{d) } x^2 + y^2 \leq 4x;$$

$$\text{e) } y \geq 2x, x \geq 1, y \leq 4;$$

$$\text{f) } \begin{cases} y \leq x \leq y + 6, \\ 1 \leq y \leq 3. \end{cases}$$

6.447. D soha (1) ko'rinishdagi tengsizliklar sistemasi bilan berilgan. Uni (2) ko'rinishdagi tengsizliklar sistemasiga keltiring:

$$\text{a) } \begin{cases} 0 \leq x \leq 5, \\ 2x^2 \leq y \leq 10x; \end{cases}$$

$$\text{b) } \begin{cases} 0 \leq x \leq 1, \\ x \leq y \leq 4x; \end{cases}$$

$$\text{d) } \begin{cases} 0 \leq x \leq 1, \\ -\sqrt{5-x^2} \leq y \leq 5-x. \end{cases}$$

6.448. Tengsizliklar sistemasining yechimlar to'plamini koordinata tekisligida tasvirlang, hosil qilingan shaklning yuzini toping:

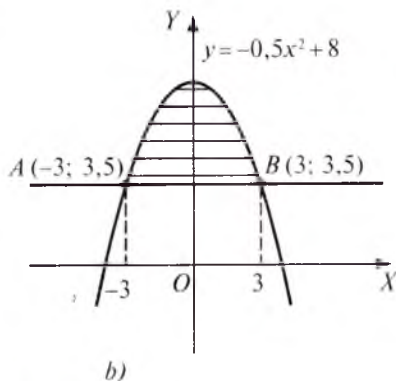
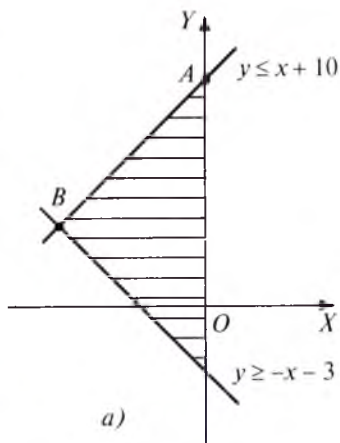

33- rasm.

$$\text{a) } \begin{cases} y \geq |x| - 4, \\ x^2 + y^2 < 9; \end{cases} \quad \text{b) } \begin{cases} xy > 16, \\ x^2 + y^2 \leq 16x. \end{cases}$$

6.449. a) Ikki to'g'ri chiziq va *Oy* o'qi; b) parabola va to'g'ri chiziq bilan chegaralangan shaklni tengsizliklar bilan ifodalang (33- *a, b* rasm).

6.450. Tengsizliklar bilan ifodalangan sohani toping va koordinata tekisligida tasvirlang:

$$\text{a) } (x^2 - 2x)(x^2 + y^2 - 15) \geq 0;$$

$$\text{b) } (x^2 - y + 1)(-x^2 - y^2 + 3) < 0.$$

7- §. Irratsional tenglamalar va tengsizliklar

1. Irratsional tenglamalar. Agar $A(x) = B(x)$ tenglamadagi $A(x)$ yoki $B(x)$ ifodalardan hech bo'lmaganda bittasi irratsional bo'lsa, u holda bu tenglama *irratsional tenglama* deyiladi. Ularni yechishda teng kuchli almashtirishlardan foydalaniladi.

Teorema. *Agar n soni musbat va toq bo'lsa, u holda $A(x) = B(x)$ va $A^n(x) = B^n(x)$ tenglamalar teng kuchli bo'ladi. Agar n soni musbat va juft bo'lsa, $A^n(x) = B^n(x)$ tenglamaning ildizi $A(x) = B(x)$ va $A(x) = -B(x)$ tenglamalardan hech bo'lmaganda bittasini qanoatlantiradi.*

Isbot. α soni $A(x) = B(x)$ tenglamaning ildizi, ya'ni $A(\alpha) = B(\alpha)$ bo'lsin. U holda $A^n(\alpha) = B^n(\alpha)$, ya'ni α soni $A^n(x) = B^n(x)$ tenglamaning ham ildizi. Aksincha, α soni $A^n(x) = B^n(x)$ ning ildizi, ya'ni $A^n(\alpha) = B^n(\alpha)$ bo'lsa, toq n larda $A(\alpha) = B(\alpha)$ bo'ladi, ya'ni $A(x) = B(x) \Leftrightarrow A^n(x) = B^n(x)$. Juft n larda $A^n(\alpha) = B^n(\alpha)$ tenglik $A(\alpha) = B(\alpha)$ bo'lganda yoki $A(\alpha) = -B(\alpha)$ da o'rinli va shunga ko'ra α soni $A(x) = B(x)$ va $A(x) = -B(x)$ tenglamalardan hech bo'lmaganda bittasining ildizi bo'ladi.

Bularga qaraganda $A(x) = B(x)$ irratsional tenglamaning ikkala qismi juft darajaga ko'tarilganda *chet ildizlar*, ya'ni $A(x) = -B(x)$ tenglamaning ildizlari paydo bo'lishi mumkin. Juft darajaga ko'targanda chet ildizlarning paydo bo'lishi mavjudlik sohasining

o'zgarishidan ham bo'lishi mumkin. Ularni aniqlash uchun topilgan ildizlarni berilgan tenglamaga qo'yib tekshirish, shuningdek, teng kuchlilik shartlariga rioya qilinganligini tekshirish kerak. Chunonchi, $A(x)$, $B(x)$ ifodalar ratsional ifoda va ${}^{2k}\sqrt{A(x)} \geq 0$, $k \in \mathbb{N}$ bo'lganda quyidagi munosabat o'rinli bo'ladi:

$${}^{2k}\sqrt{A(x)} = B(x) \Leftrightarrow \begin{cases} A(x) = B^{2k}(x), \\ B(x) \geq 0. \end{cases}$$

1- misol. $\sqrt{x^2 + 3x + 1} = x - 2$ tenglamani yeching.

Yechish. Tenglama ushbu sistemaga teng kuchli:

$$\begin{cases} x^2 + 3x + 1 = (x - 2)^2, \\ x - 2 \geq 0. \end{cases}$$

$x^2 + 3x + 1 = (x - 2)^2$ tenglama yagona $x = \frac{3}{7}$ ildizga ega.

Lekin u $x - 2 \geq 0$ tengsizligini qanoatlantirmaydi. Tenglama yechimga ega emas.

2- misol. $\sqrt{-3x^2 + 3x - 2} = \sqrt{-2x - 10}$ tenglamani yeching.

Yechish. Tenglama ushbu sistemaga teng kuchli:

$$-3x^2 + 3x - 2 = -2x - 10, \quad -2x - 10 \geq 0.$$

$-3x^2 + 3x - 2 = -2x - 10$ tenglamaning ildizlari -1 va $2\frac{2}{3}$.

Lekin bu qiymatlarda $-2x - 10 \geq 0$ tengsizligi bajarilmaydi. Demak, berilgan tenglama ildizga ega emas.

3- misol. $x^2 - 3x - 11 + \sqrt{x^2 - 3x - 9} = 0$ tenglamani yeching.

Yechish. $y = \sqrt{x^2 - 3x - 9}$ almashtirish tenglamani $y^2 - 2 + y = 0$ ko'rinishga keltiradi. Uning ildizlari $y_1 = -2$, $y_2 = 1$ sonlari bo'lgani uchun, eski o'zgaruvchiga qaytish natijasida yechimga ega bo'lmagan $\sqrt{x^2 - 3x - 9} = -2$ tenglamaga hamda $x_1 = -2$,

$x_2 = 5$ ildizlarga ega bo'lgan $\sqrt{x^2 - 3x - 9} = 1$ tenglamaga ega bo'lamiz. Demak, berilgan tenglama $x_1 = -2$, $x_2 = 5$ ildizlarga ega.

4- misol. $\sqrt{x^2 - 8x + 16} + \sqrt{x^2 - 4x + 4} = 2$ tenglamani yeching.

Yechish. $\sqrt{x^2 - 8x + 16} = |x - 4|$ va $\sqrt{x^2 - 4x + 4} = |x - 2|$ bo'lgani uchun berilgan tenglama $|x - 4| + |x - 2| = 2$ ko'rinishga keladi. Modul qatnashgan bu tenglama barcha $x \in [2; 4]$ lardagina to'g'ri tenglikka aylanadi.



Mashqlar

Tenglamalarni mantiqiy mulohazalar yuritib yeching:

6.451. $\sqrt{x+2} + \sqrt{2x-1} = -3$.

6.452. $4 + \sqrt{2y-3} = 1$.

6.453. $6 - \sqrt{x+\sqrt{2}} = 7$.

6.454. $\sqrt{10 + \sqrt{x - \sqrt{3}}} = 3$.

6.455. $\sqrt{x-3} + \sqrt{2-x} = 5$.

6.456. $\sqrt{x-4} + \sqrt{4-x} = 1$.

6.457. $\sqrt{x-4} + \sqrt{4-x} = -1$.

6.458. $\sqrt{x+4} + \sqrt{-x-5} = 0$.

Tenglamalarni aniqlanish sohasini topish bilan yeching:

6.459. $x + \sqrt{x-1} + 2 = \sqrt{x-1}$.

6.460. $\sqrt{-x^2 + x + 6} = 2x - 7$.

6.461. $\sqrt{-x^2 - 3x - 2} = x - 1$.

6.462. $\sqrt{x^2 - 4x + 3} = \sqrt{5x - 6 - x^2}$.

6.463. $\sqrt{2x^2 - 7x + 3} = \sqrt{5x - 2 - x^2}$.

$$6.464. \sqrt{y-3} - 6\sqrt{2-y} = 8.$$

$$6.465. (x^2 - 1)\sqrt{2x-1} = 0.$$

$$6.466. (x^2 - 4)\sqrt{x+1} = 0.$$

$$6.467. (9 - x^2)\sqrt{2-x} = 0.$$

$$6.468. (16 - x^2)\sqrt{3-x} = 0.$$

Tenglamalarni $2\eta\sqrt{f(x)} = g(x)$ tenglama bilan $\begin{cases} f(x) = (g(x))^2, \\ g(x) \geq 0 \end{cases}$

sistemaning teng kuchliligidan foydalanib yeching:

$$6.469. \sqrt{12-x} = x.$$

$$6.470. \sqrt{7-x} = x-1.$$

$$6.471. x - \sqrt{x+1} = 5.$$

$$6.472. 21 + \sqrt{2x-7} = x.$$

$$6.473. 1 - \sqrt{1+5x} = x.$$

$$6.474. 2\sqrt{x+5} = x+2.$$

$$6.475. 4\sqrt{x+6} = x+1.$$

$$6.476. \sqrt{4+2x-x^2} = x-2.$$

$$6.477. \sqrt{37-x^2} + 5 = x.$$

$$6.478. \sqrt{6-4x-x^2} = x+4.$$

$$6.479. \sqrt{1+4x-x^2} = x-16.$$

Tenglamalarni yangi o'zgaruvchi kiritib yeching:

$$6.480. x^2 - 4x + 6 = \sqrt{2x^2 - 8x + 12}.$$

$$6.481. 2x^2 + 3x - 5\sqrt{x^2 + 3x + 9} + 3 = 0.$$

$$6.482. x^2 + \sqrt{x^2 + 2x + 8} = 12 - 2x.$$

$$6.483. 2x^2 + \sqrt{2x^2 - 4x + 12} = 4x + 8.$$

$$6.484. 3x^2 + 15x + 2\sqrt{x^2 + 5x + 1} = 2.$$

$$6.485. \sqrt[3]{x} + 2\sqrt[3]{x^2} = 3.$$

$$6.486. \sqrt[3]{x^2} - \sqrt[3]{x} - 6 = 0.$$

$$6.487. \frac{4}{\sqrt{x+2}} + \frac{\sqrt[3]{x+3}}{5} = 2.$$

$$6.488. \frac{8}{\sqrt{10-2x}} - \sqrt{10-2x} = 2.$$

$$6.489. \sqrt{2-x} + \frac{4}{\sqrt{2-x+3}} = 2.$$

$$6.490. \sqrt{\frac{3-x}{2+x}} + 3\sqrt{\frac{2+x}{3-x}} = 4.$$

$$6.491. \sqrt{\frac{2x+1}{x-1}} - 2\sqrt{\frac{x-1}{2x+1}} = 1.$$

Tenglamalarni darajaga ko'tarish usuli bilan yeching:

$$6.492. \sqrt{x+1} = 8 - \sqrt{3x+1}.$$

$$6.493. \sqrt{x + \sqrt{x+11}} + \sqrt{x - \sqrt{x+11}} = 4.$$

$$6.494. \sqrt{x^2+1} + \sqrt{x^2-2x+3} = 3.$$

$$6.495. \sqrt{x^2+x-5} + \sqrt{x^2+8x-4} = 5.$$

$$6.496. \sqrt{4x-3} + \sqrt{5x+1} = \sqrt{15x+4}.$$

$$6.497. \sqrt{x+5} + \sqrt{x+3} = \sqrt{2x+7}.$$

$$6.498. \sqrt[3]{x+34} - \sqrt[3]{x-3} = 1.$$

$$6.499. \sqrt[3]{x} + \sqrt[3]{x-16} = \sqrt[3]{x-8}.$$

$$6.500. \sqrt[3]{x+5} + \sqrt[3]{x+6} = \sqrt[3]{2x+11}.$$

$$6.501. \sqrt[3]{x+1} + \sqrt[3]{3x+1} = \sqrt[3]{x-1}.$$

$$6.502. \sqrt[3]{1+\sqrt{x}} + \sqrt[3]{1-\sqrt{x}} = 2.$$

$$6.503. \sqrt[3]{5x+7} + \sqrt[3]{5x-12} = 1.$$

$$6.504. \sqrt[3]{9-\sqrt{x+1}} + \sqrt[3]{7+\sqrt{x+1}} = 4.$$

$$6.505. \sqrt[3]{24+\sqrt{x}} - \sqrt[3]{5+\sqrt{x}} = 1.$$

$$6.506. \sqrt[3]{x^2-2x} - \sqrt[3]{2x^2-7x+6} = 0.$$

$$6.507. \sqrt[3]{x+34} - \sqrt[3]{x-3} = 1.$$

Tenglamalarni «qo'shmasiga ko'paytirish usuli» bilan yeching:

$$6.508. \sqrt{3x^2 + 5x + 8} - \sqrt{3x^2 + 5x + 1} = 1.$$

$$6.509. \sqrt{3x^2 - 2x + 15} + \sqrt{3x^2 - 2x + 8} = 7.$$

$$6.510. \sqrt{x^2 + 9} - \sqrt{x^2 - 7} = 2.$$

$$6.511. \sqrt{15-x} + \sqrt{3-x} = 6.$$

Tenglamalarni yeching:

$$6.512. \sqrt{x^2 + 3x - 3} = 2x - 3.$$

$$6.513. \sqrt{9x^2 + 2x - 3} = 3x - 2.$$

$$6.514. (x+2)(x-5) + 3\sqrt{x(x+3)} = 0.$$

$$6.515. \sqrt{x+2\sqrt{x-1}} - \sqrt{x-2\sqrt{x-1}} = 2.$$

$$6.516. \sqrt{x-3-2\sqrt{x-4}} + \sqrt{x-4\sqrt{x-4}} = 1.$$

$$6.517. \sqrt{5x+7} - \sqrt{x+3} = \sqrt{3x+1}.$$

$$6.518. \sqrt{x+4} + 2\sqrt{x+1} = \sqrt{x+20}.$$

$$6.519. \sqrt[3]{x+1} + \sqrt[3]{x-1} = \sqrt[3]{5x}.$$

$$6.520. \sqrt[3]{x-2} + \sqrt[3]{x+3} = \sqrt[3]{2x+1}.$$

$$6.521. \sqrt[3]{x+1} - \sqrt[3]{x-1} = \sqrt[6]{x^2-1}.$$

$$6.522. \sqrt{x+1} = a.$$

$$6.523. \sqrt{x+3} = \sqrt{a-x}.$$

$$6.524. \sqrt{\frac{x+a}{x-a}} + 2\sqrt{\frac{x-a}{x+a}} = 3.$$

$$6.525. \sqrt{7-x} - \sqrt{x-3} = a.$$

$$6.526. \sqrt{2x-1} - x + a = 0.$$

$$6.527. 2 + \frac{2x}{\sqrt{2+x^2}} = \sqrt{2}.$$

2. Irratsional tengsizliklar. a va b sonlari nomanfiy bo'lgandagina $a < b$ dan $a^n < b^n$ kelib chiqadi (va aksincha, $a^n < b^n \Leftrightarrow a < b$). Shunga ko'ra $A(x)$, $B(x)$ irratsional ifodali tengsizliklarni yechishda ularning ishoralari e'tiborga olinishi kerak. Umuman,

$${}^{2k}\sqrt{A(x)} < B(x) \Leftrightarrow \begin{cases} A(x) \geq 0, \\ B(x) > 0, \\ A(x) < B^{2k}(x) \end{cases} \quad (1)$$

bo'ladi. Sistemadagi birinchi tengsizlik ildiz ostidagi ifodaning nomanfiyligini, ikkinchisi $B(x)$ ning musbatligini ifodalaydi, uchinchisi $a \geq 0$, $b \geq 0$ da $a < b$ va $a^{2k} < b^{2k}$ tengsizliklar bir vaqtda bajarilishidan kelib chiqadi. ${}^{2k}\sqrt{A(x)} > B(x)$ tengsizligi $B(x) \geq 0$, $A(x) > B^{2k}(x)$ bo'lganda yoki $A(x) \geq 0$, $B(x) < 0$ bo'lganda o'rinli. Shunga ko'ra ${}^{2k}\sqrt{A(x)} > B(x)$ tengsizlikni yechish uchun

$$\begin{cases} B(x) \geq 0, \\ A(x) > B^{2k}(x) \end{cases} \quad (2) \quad \text{va} \quad \begin{cases} A(x) \geq 0, \\ B(x) < 0 \end{cases} \quad (3)$$

tengsizliklar sistemalarini yechish va ularning yechimlarini birlashtirish kerak.

1- misol. $\sqrt{x^2 + 6x - 16} > x - 1$ tengsizlikni yeching.

Yechish. Berilgan tengsizlikdan ushbu tengsizliklar sistemalari hosil bo'ladi:

$$\begin{cases} x - 1 \geq 0, \\ x^2 + 6x - 16 > x^2 - 2x + 1 \end{cases} \quad \text{va} \quad \begin{cases} x^2 + 6x - 16 \geq 0, \\ x - 1 < 0. \end{cases}$$

Birinchi sistemaning yechimi $\left(2\frac{1}{8}; +\infty\right)$ to'plamdan, ikkinchi sistemaniki $(-\infty; -8)$ to'plamdan iborat.

Javob: $(-\infty; -8) \cup \left(2\frac{1}{8}; +\infty\right)$.

Agar irratsional tengsizlik

$$\sqrt{A(x)} + \sqrt{B(x)} < C(x) \quad (4)$$

ko'rinishda berilgan bo'lsa, $A(x) \geq 0$, $B(x) \geq 0$ va $\sqrt{B(x)} < C(x)$ (yoki $\sqrt{A(x)} < C(x)$) shartlar bajarilganda berilgan tengsizlik $A(x) < (C(x) - \sqrt{B(x)})^2$ (yoki $B(x) < (C(x) - \sqrt{A(x)})^2$) tengsizlikka teng kuchli bo'lib, yuqorida qaralgan turlardan biriga keladi.

2- misol. $\sqrt{x-1} + \sqrt{x+4} < 5$ tengsizlikni yeching.

Yechish.

$$\begin{cases} x-1 \geq 0, \\ x+4 \geq 0, \\ \sqrt{x-1} < 5, \\ x+4 < (5 - \sqrt{x-1})^2 \end{cases} \Rightarrow \begin{cases} x \geq 1, \\ x \geq -4, \\ x < 26, \\ x < 5. \end{cases} \Rightarrow 1 \leq x < 5,$$

Javob: $1 \leq x < 5$.

Tengsizliklarni mantiqiy mulohazalar yuritib yeching:

6.528. $\sqrt{x+3} \geq -5$.

6.529. $\sqrt{x^2+1} > -1$.

6.530. $\sqrt{x^2-2x+4} > -\frac{1}{2}$.

6.531. $\sqrt{x^2-2x+4} < 0$.

6.532. $\sqrt{x^2-6x+9} \geq 0$.

6.533. $\sqrt{|x-2|+x^2+4} < 0$.

6.534. $\sqrt{x^2-2x+3} \geq -0,3$.

6.535. $\sqrt{x^2} > 0$.

6.536. $\sqrt{x-4} + \sqrt{3-x} > 0$.

6.537. $\sqrt{x-4} + \sqrt{3+x} < 0$.

6.538. $\sqrt{x^2-3x+2} \geq 0$.

6.539. $\sqrt{4y^2+4y+1} > 0$.

6.540. $\sqrt{x^2+x+1} > 0$.

6.541. $\sqrt{5x-6-x^2} > 0$.

6.542. $\sqrt{x-1-x^2} > 0$.

6.543. $\sqrt{5x-18-x^2} > 0$.

6.544. $(x-1)\sqrt{x^2-x-2} \geq 0$.

6.545. $(3-x)\sqrt{x^2+x-2} \leq 0$.

6.546. $\frac{x^{-7}}{\sqrt{4x^2-19x+12}} < 0$.

$$6.547. \frac{\sqrt{2x^2+15x-17}}{10-x} \geq 0.$$

$$6.548. \frac{\sqrt{x^2-x-2}}{x^2+2x-3} > 0.$$

$$6.549. \frac{x^2-3x-6}{\sqrt{x^2-4x+3}} < 0.$$

Tengsizliklarni yeching:

$$6.550. \sqrt{x+7} < x.$$

$$6.551. \sqrt{x^2+4x+4} < x+6.$$

$$6.552. \sqrt{2x^2-3x-5} < x-1.$$

$$6.553. \sqrt{x+78} < x+6.$$

$$6.554. \sqrt{(x+2)(x-5)} < 8-x.$$

$$6.555. 1 - \sqrt{13+3x^2} > 2x.$$

$$6.556. \sqrt{x^2+x-12} < x.$$

$$6.557. \sqrt{2x+4} > x+3.$$

$$6.558. \sqrt{x^2+x-2} > x.$$

$$6.559. \sqrt{9-24x+16x^2} > 8.$$

$$6.560. \sqrt{(x+4)(x+3)} > 6-x.$$

$$6.561. \sqrt{x^2-5x-24} > x+2.$$

$$6.562. \sqrt{x^2-4x} > x-4.$$

$$6.563. \sqrt{x^2-x-6} \leq x+5.$$

$$6.564. \sqrt{x^2-5x+6} \leq x+1.$$

- 6.565. $\sqrt{x^2 - 7x + 12} \geq 1 - x$.
- 6.566. $3\sqrt{x} - \sqrt{x+3} > 1$.
- 6.567. $\sqrt{x+3} + \sqrt{x+2} - \sqrt{2x+4} > 0$.
- 6.568. $\sqrt{x-6} - \sqrt{10-x} \geq 1$.
- 6.569. $\sqrt{x+3} - \sqrt{x-1} > \sqrt{2x-1}$.
- 6.570. $\sqrt{3x^2 + 5x + 7} - \sqrt{3x^2 + 5x + 2} > 1$.
- 6.571. $\sqrt{1-x} \leq \sqrt[4]{5-x}$.
- 6.572. $\sqrt[4]{5x-1} \leq \sqrt{x}\sqrt{6}$.
- 6.573. $\sqrt{1-x^2} + 1 < \sqrt{3-x^2}$.
- 6.574. $\sqrt{x+3} < \sqrt{x+1} + \sqrt{x-2}$.
- 6.575. $\sqrt{x+2\sqrt{x-1}} + \sqrt{x-2\sqrt{x-1}} > \frac{3}{2}$.
- 6.576. $\sqrt{x^2 - x - 12} < 7 - x$.
- 6.577. $\sqrt{x^2 - 5x + 6} < 2x - 3$.
- 6.578. $\frac{\sqrt{x+2}}{x} < 1$.
- 6.579. $\sqrt{x+\sqrt{x}} - \sqrt{x-\sqrt{x}} > 1,5\sqrt{\frac{x}{x+\sqrt{x}}}$.
- 6.580. $\sqrt{x^2 - 5x + 6} + \frac{1}{\sqrt{x^2 - 5x + 6}} \geq 2$.
- 6.581. $\frac{1}{\sqrt{3x-2}} + \sqrt{3x+2} > 2$.
- 6.582. $\sqrt{x^2 - x - 2} + \frac{1}{\sqrt{x^2 - x - 2}} > 2$.
- 6.583. $\sqrt{3-4x} + \frac{1}{\sqrt{3-4x}} < 2$.
- 6.584. $\sqrt{x^2 + 4x + 4} < x + 6$.

$$6.585. \sqrt{16x^2 - 24x + 9} < \sqrt{4x^2 + 12x + 9}.$$

$$6.586. \sqrt{x^2 + 2x + 1} + \sqrt{x^2 - 6x + 9} < 8.$$

$$6.587. \sqrt{x^4 + 2x^2 + 1} + \sqrt{4x^4 - 4x^2 + 1} \leq 2x - 1.$$

$$6.588. \sqrt{x} - 3 \leq \frac{2}{\sqrt{x-2}}.$$

$$6.589. 5\sqrt{x} > x + 6.$$

$$6.590. \frac{x-1}{\sqrt{x+1}} > 4 + \frac{\sqrt{x-1}}{2}.$$

$$6.591. \frac{1}{\sqrt{2-x}} > \frac{1}{x-1}.$$

$$6.592. \frac{1}{\sqrt{1+x}} > \frac{1}{2-x}.$$

$$6.593. \frac{\sqrt{3x^2+4}}{x-1} \geq 4.$$

$$6.594. a\sqrt{x+1} < 1.$$

$$6.595. \sqrt{a+x} + \sqrt{a-x} > a.$$



VII b o b

FUNKSIYALAR

1- §. Sonli funksiyalar

1. Funksiya va argument. Amaliyotda vaqt, temperatura, bosim, kuch, tezlik, yuz, hajm va hokazo miqdorlar (kattaliklar) bilan ish ko'rishga, ular orasidagi bog'lanishlarning xususiyatlarini o'rganishga to'g'ri keladi. Bunga ko'plab misollarni fizika, geometriya, biologiya va boshqa fanlar beradi. Jism o'tgan S masofaning t vaqtga, aylana C uzunligining R radiusga bog'liq ravishda o'zgarishi bunga oddiy misol.

Agar x o'zgaruvchi miqdor X sonli to'plamdan qabul qila oladigan har bir qiymatga biror f qoida bo'yicha y o'zgaruvchi miqdorning Y sonli to'plamdagi aniq bir qiymati mos kelsa, y o'zgaruvchi x o'zgaruvchining *sonli funksiyasi* deb ataladi. y o'zgaruvchining x o'zgaruvchiga bog'liq ekanligini ta'kidlash maqsadida uni *erksiz o'zgaruvchi* yoki funksiya, x o'zgaruvchini esa *erkli o'zgaruvchi* yoki argument deb ataymiz. y o'zgaruvchi x o'zgaruvchining funksiyasi ekanligi $y=f(x)$ ko'rinishda belgilanadi.

Argument x ning X to'plamdan qabul qila oladigan barcha qiymatlar to'plami f funksiyaning *aniqlanish sohasi* deyiladi va $D(f)$ orqali belgilanadi. $\{f(x) \mid x \in D(f)\}$ to'plam f funksiyaning *qiymatlar sohasi (to'plami)* deb ataladi va $E(f)$ orqali belgilanadi.

Ixtiyoriy $x \in D(f)$ qiymatda funksiya faqat $y = b$ (o'zgarmas miqdor — *constant*), $b \in R$ qiymatga ega bo'lsa, unga X to'plamda berilgan *doimiy funksiya* deyiladi. Masalan, koordinatalar sistemasida Ox o'qqa parallel to'g'ri chiziqni ifodalovchi $y = 3$ funksiya $D(f) = \{x \mid -\infty < x < +\infty\}$ da doimiydir.

1- m i s o l. Agar $y = x^2$ funksiya R to'plamda berilgan bo'lsa, u holda $D(f) = R$ va $E(f) = R_+ \cup \{0\}$ bo'ladi.

2- m i s o l. $y = x^2$ funksiya $D(f) = [-3; 4]$ da berilgan bo'lsin. Bu funksiyaning qiymatlar sohasi $E(f) = [0; 16]$ dan iborat.



Mashqlar

Funksiyalarning aniqlanish sohaslarini toping (7.1–7.43):

$$7.1. f(x) = \frac{3}{x-2}.$$

$$7.2. f(x) = \frac{3x}{x-3,4}.$$

$$7.3. f(x) = \frac{4x-1}{3x-2}.$$

$$7.4. f(x) = \frac{4x+13}{7x+14}.$$

$$7.5. f(x) = \frac{4x}{(x-1)(x-2)}.$$

$$7.6. f(x) = \frac{3x-1}{(x-1)(x-2)(x-3)}.$$

$$7.7. f(x) = \frac{4x^2-1}{x^2-7x+12}.$$

$$7.8. f(x) = \frac{4x+1}{x^2-8x+15}.$$

$$7.9. f(x) = \frac{1}{x^2+3}.$$

$$7.10. f(x) = \frac{1}{x^2-x+1}.$$

$$7.11. f(x) = \frac{x}{x^2+x+1}.$$

$$7.12. f(x) = \frac{x^2}{x^2+x+1}.$$

$$7.13. f(x) = x + x^2 + \frac{1}{x-3}.$$

$$7.14. f(x) = x^2 + x - 3.$$

$$7.15. f(x) = x + \frac{1}{x} + \frac{1}{x^2-1}.$$

$$7.16. f(x) = \left(x + \frac{1}{2}\right)^2 + \frac{1}{x^2-1}.$$

$$7.17. f(x) = x + x^{-1} + x^{-2}.$$

$$7.18. f(x) = x^{-1} + \frac{2}{x}.$$

$$7.19. f(x) = \frac{1}{x-2} + \frac{1}{(x^2-3x)^2}.$$

$$7.20. f(x) = \frac{1}{x^2+3}.$$

$$7.21. y = \sqrt{3-5x}.$$

$$7.22. f(x) = \frac{1+x}{\sqrt{3-2(7-5x)}}.$$

$$7.23. y = \sqrt{2(3x-1)-7x+2}.$$

$$7.24. y = \frac{3+4x}{\sqrt{3-2x-4(1-5x)}}.$$

$$7.25. y = \sqrt{-\sqrt{2}(2-3x)}.$$

$$7.26. y = \frac{1}{\sqrt{(3x-1)\sqrt{2-3x+2}}}.$$

$$7.27. y = \frac{2}{\sqrt{(x-\sqrt{3})\sqrt{3-2x+1}}}$$

$$7.28. y = \sqrt{60x - 25x^2 - 36}$$

$$7.29. y = \frac{1}{\sqrt{112x+64+49x^2}}$$

$$7.30. y = \sqrt{5x^2 + 6x + 1} + \frac{1}{3x+5}$$

$$7.31. y = \sqrt{3x+4} - \frac{1}{\sqrt{-2x^2-5x-2}}$$

$$7.32. y = \sqrt{4-x|x|}$$

$$7.33. y = \sqrt{|x|(x-1)}$$

$$7.34. y = \sqrt{(x-2)\sqrt{x}}$$

$$7.35. y = \sqrt{(1-x)\sqrt{x-2}}$$

$$7.36. y = \sqrt{\frac{-x^2+6x-8}{x^2+5x+6}}$$

$$7.37. y = \frac{2}{\sqrt{x^2+x-20}} + \sqrt{x^2+5x-14}$$

$$7.38. y = \sqrt{\frac{\sqrt{17-15x-2x^2}}{x+3}}$$

$$7.39. y = \sqrt{\frac{7-x}{\sqrt{4x^2-19x+12}}}$$

$$7.40. y = \sqrt{\frac{-4x^2+4x+3}{\sqrt{2x^2-7x+3}}}$$

$$7.41. y = \sqrt{12x^2-4x^3-9x} - \sqrt{2-|x|}$$

$$7.42. y = \sqrt{|x-1|(3x-6)} + \frac{3}{x^2+4x-21}$$

$$7.43. y = \sqrt{5-\sqrt{4x^2-20x+25}} - \sqrt{|x|(2x-10)}$$

Funksiyalarning qiymatlar sohasini toping (7.44–7.70):

$$7.44. y = 1. \quad 7.45. y = x. \quad 7.46. y = x^2. \quad 7.47. y = -x^2.$$

$$7.48. y = x^2 + 2. \quad 7.49. y = 3 - 4x^2. \quad 7.50. y = 3x - x^2.$$

$$7.51. y = 3x^2 - 6x + 1.$$

$$7.52. y = \frac{5}{x-2}.$$

7.53. $y = \frac{x}{x+1}$.

7.54. $y = \frac{2}{x^2+2}$.

7.55. $y = \frac{x^2+1}{x}$.

7.56. $y = \sqrt{x-2} + 3$.

7.57. $y = |x-4| - 2$.

7.58. $y = 5 - \sqrt{2x+1}$.

7.59. $y = 3 - |2x+3|$.

7.60. $y = \sqrt{x^2+4}$.

7.61. $y = 4 - 2\sqrt{x^2+9}$.

7.62. $y = \sqrt{3x^2-6x+4}$.

7.63. $y = \sqrt{8x-2x^2-7}$.

7.64. $y = 1 - \frac{5}{\sqrt{x-1}+1}$.

7.65. $y = 2 - \frac{3}{2x^2-8x+9}$.

7.66. $y = 1 - \sqrt{9 - \sqrt{2x^2 + 6\sqrt{2}x + 9}}$.

7.67. $y = 3 - \sqrt{16 - \sqrt{4x^2 - 4\sqrt{3}x + 3}}$.

7.68. $y = \frac{x^3+8}{x+2}$. 7.69. $y = \frac{(x^3+8)(x-4)}{x^2-2x-8}$. 7.70. $y = \frac{x^3-27}{x-3}$.

7.71. Quyida ko'rsatilgan kattaliklarning qaysi biri ikkinchisiga, qaysi holda ikkinchisi birinchisiga funksional bog'liq bo'lishi mumkin:

- a) shaxtadagi ko'mir lavasining uzunligi va mehnat unumdorligi;
- b) havoning issiqligi va unda tovushning tarqalish tezligi;
- d) aylana uzunligi va radiusi;
- e) kvadratning diagonalini va yuzi?

7.72. Metall sterjen qizdirilganda uning cho'zilishi qanday kattaliklarga funksional bog'liq bo'ladi?

7.73. Geometriya va fizika kurslaridan sizga tanish ikki va uch o'zgaruvchili funksiyalarga misollar keltiring.

7.74. Quyida ko'rsatilgan (1), (2), (3), (4) munosabatlar funksional bog'lanishmi? Ularda qanday o'zgaruvchi miqdorlar qatnashmoqda? Qaysilari argument vazifasini bajaradi? Aniqlanish va qiymatlar sohasini toping:

a) Nyuton ikkinchi qonunining ifodasi

$$F = ma, \quad (1)$$

bunda F – jismga ta'sir etayotgan kuch, m – jism massasi, a – jism olgan harakat tezlanishi;

b)
$$a = \frac{v - v_0}{t}, \quad (2)$$

bunda v_0 va v – jismning boshlang'ich va t vaqtdan keyingi tezligi;

d)
$$F = \frac{m(v - v_0)}{t}. \quad (3)$$

Bu munosabat (1) va (2) munosabatlardan qanday hosil qilingan?

e) (3) munosabat bo'yicha

$$Ft = mv - mv_0 \quad (4)$$

hosil qilingan. (3) va (4) munosabatlar teng kuchlimi? Bunda Ft – kuch impulsi (zarba), $mv - mv_0$ – jism impulsining (harakat miqdorining) o'zgarishi;

f) agar $m = 100$ g, $a = 15$ sm/s², $v_0 = 2$ sm/s, $t = 10$ s bo'lsa, F (dina), v , Ft , $mv - mv_0$ larning qiymatlarini toping.

7.75. $f(x) = 3 - x^2 - |x|$ funksiyaning $f(3)$, $f(0)$, $f(-4)$, $f(c - 1)$ qiymatlarini toping.

7.76. Radiusi R ga teng bo'lgan doiraga: a) ichki; b) tashqi chizilgan to'g'ri to'rtburchakning tomonlaridan biri x ga teng (34-a, b rasm). To'g'ri to'rtburchak yuzini x ga bog'liq funksiya sifatida ifodalang. Bu funksiyaning aniqlanish va qiymatlar sohasini toping.

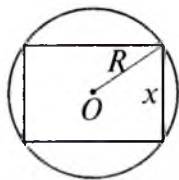

a)

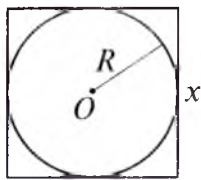

b)

34- rasm.

7.77. To'g'ri burchakli uchburchak gipotenuzasiga tushirilgan balandlik h ga teng. Uning yuzi va perimetrini katetlaridan birining x uzunligi funksiyasi sifatida ifodalang.

7.78. V l idishdagi $p\%$ li eritmadan x l olinib, o'rniga x l suv qo'shilgan. Shu ish yana uch marta takrorlangan. Natijada hosil bo'ladigan eritma konsentratsiyasini x ning funksiyasi sifatida ifodalang.

2. Funksiyani bo'laklarga ajratib berish. Aniqlanish sohasining turli qismlarida turli xil qoida bilan berilgan funktsiyani *bo'laklarga ajratib berilgan funktsiya* (yoki *bo'lakli berilgan funktsiya*) deb ataymiz.

1 - m i s o l. Jism harakatni boshlab, dastlabki t_1 vaqt davomida tekis tezlanuvchan (a_1 tezlanish bilan), so'ng t_2 vaqt davomida tekis sekinlanuvchan ($-a_2$ tezlanish bilan) harakat qilgan. Uning v harakat tezligini t ning funksiyasi sifatida ifodalaymiz.

Y e c h i s h . 1) Jismning harakat boshidagi tezligi $v_0 = 0$, jism t_1 vaqt davomida tekis tezlanuvchan harakat qilgan: $v = v_0 + a_1 t = a_1 t$, $0 \leq t \leq t_1$; 2) t_1 vaqt momentidagi tezligi $v_1 = a_1 t_1$; keyingi t_2 vaqt davomida tekis sekinlanuvchan harakat qilgan: $v = v_1 - a_2 t = a_1 t_1 - a_2 t$, $t_1 \leq t \leq t_1 + t_2$. Shunday qilib,

$$v = \begin{cases} a_1 t, & 0 \leq t \leq t_1, \\ a_1 t_1 - a_2 t, & t_1 \leq t \leq t_1 + t_2. \end{cases}$$

2 - m i s o l. Koordinatalar tekisligida $f(x)$ funktsiya $ABCD$ sinig chiziq ko'rinishida tasvirlangan (35- rasm). Uning tugunlari

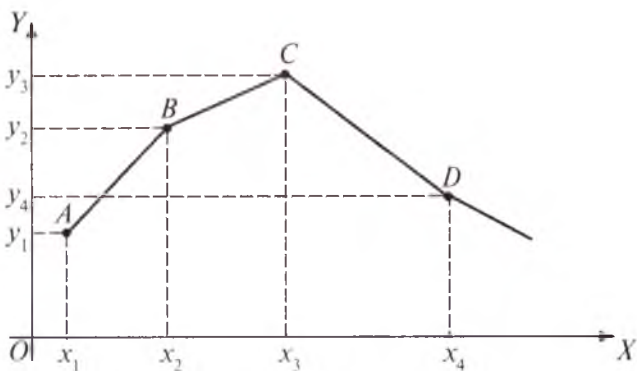

35- rasm.

$A(x_1; y_1), B(x_2; y_2), C(x_3; y_3), D(x_4; y_4)$ nuqtalarda yotadi. Funktsiyaning ifodasini yozing.

Y e c h i s h . Ikki nuqta ustidan o'tuvchi to'g'ri chiziq tenglamasidan foydalanamiz. AB bo'g'in uchun:

$$\frac{y-y_1}{y_2-y_1} = \frac{x-x_1}{x_2-x_1} \quad \text{yoki} \quad y = y_1 + \frac{y_2-y_1}{x_2-x_1}(x-x_1).$$

Qolgan bo'g'inlarning tenglamalari ham shu kabi aniqlanadi. Natijada funksiya ifodasi quyidagi ko'rinishga ega bo'ladi:

$$f(x) = \begin{cases} y_1 + \frac{y_2-y_1}{x_2-x_1}(x-x_1), & x_1 \leq x \leq x_2, \\ y_2 + \frac{y_3-y_2}{x_3-x_2}(x-x_2), & x_2 \leq x \leq x_3, \\ y_3 + \frac{y_4-y_3}{x_4-x_3}(x-x_3), & x_3 \leq x \leq x_4. \end{cases}$$

3 - misol. Quyida Mirzo Ulug'bekning 60 li sanoq sistemasida yozilgan «Jadval-ul-jayb»idan (sinuslar jadvalidan) bir parcha keltirilgan (oltmishli raqamlarning ostiga chizilgan):

i	x_i	$y_i = \sin x_i$	$\Delta y = y_{i+1} - y_i$
1	9°42'	0,106534222	0,0115555
2	43'	0,107553817	0,0115544
3	44'	0,10857341	

Bu funksiya grafigi ikki bo'g'inli siniq chiziq, tugunlari $(x_i; y_i)$ nuqtalarda joylashgan. Funksiya ifodasini tuzamiz (hisoblashlarni EHMda bajaramiz). Shu maqsadda 2- misol (1) formulasidan foydalanamiz. Oldin oltmishli kasrlarni bizga tanish o'nli kasrlarga aylantiramiz. Buning uchun sonning har qaysi k -xonada turgan raqami 60^{-k} ga ko'paytiriladi va topilgan natijalar qo'shiladi. Masalan, $0,107553817_{(60)} = 0 \cdot 60^0 + 10 \cdot 60^{-1} + 7 \cdot 60^{-2} + 55 \cdot 60^{-3} + 38 \cdot 60^{-4} + 17 \cdot 60^{-5} = \frac{1}{60} \left(10 + \frac{1}{60} \left(7 + \frac{1}{60} \left(55 + \frac{1}{60} \left(38 + \frac{17}{60} \right) \right) \right) \right) = 0,1685819725.$

Javob:

$$f(x) = \begin{cases} 0,1685819725 + \frac{0,0002867218}{1'} \cdot (x - 9^\circ 42'), & 9^\circ 42' \leq x \leq 9^\circ 43', \\ 0,1685819725 + \frac{0,0002867077}{1'} \cdot (x - 9^\circ 42'), & 9^\circ 42' \leq x \leq 9^\circ 44'. \end{cases}$$



Mashqlar

7.79. Agar $f(x) = \begin{cases} x^2 - x + 2, & -2 \leq x < -1, \\ x(5 - x), & -1 \leq x < 0, \\ \frac{x+3}{x+1}, & 0 \leq x < 1 \end{cases}$

bo'lsa, $f(-2)$, $f(-1)$, $f(-0,5)$, $f\left(\frac{\sqrt{2}}{2}\right)$ larni toping.

7.80. To'g'ri to'rtburchak bilan teng yonli uchburchak va to'g'ri to'rtburchak bilan yarim doiradan iborat shakllarning (36- a , b rasm) asoslariga parallel holda siljiydigan to'g'ri chiziq ostidagi $S(x)$ yuzni (shtrixlangan) o'zgaruvchan x uzoqlikning funksiyasi sifatida ifodalang, bunda a , b lar berilgan.

7.81. Agar 36- a rasmda siljiydigan k to'g'ri chiziq to'g'ri to'rtburchakning asosiga parallel va undan x uzoqlikda bo'lsa, $S(x)$ yuzni x ning funksiyasi sifatida ifodalang.

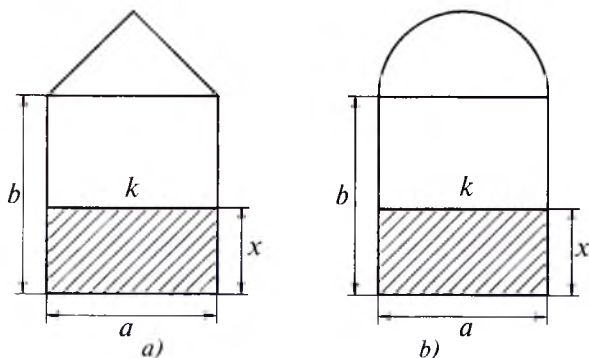

36- rasm.

- 7.82.** Termodinamikada gazning bajargan A ishi uning idishga P bosimi va gaz V hajmining V_{i-1} dan V_i gacha $\Delta V = V_i - V_{i-1}$ o'zgarishiga bog'liqligi $A = P \cdot \Delta V$ munosabat orqali ifodalanadi. Agar

$$A = \begin{cases} 3 \cdot \Delta V, & 2 \leq V < 4, \\ P \cdot \Delta V, & 4 \leq V < 8, \end{cases} \quad P = \frac{12}{V}$$

bo'lsa, $A(3)$, $A(4)$, $A(5)$ larni toping.

- 7.83.** Mirzo Ulug'bekning «Jadval-ul-jayb»idan bir parcha:

x_i	$f(x_i)$	$\Delta f(x)$
8°42'	0,08 04 32 20 14	0,00 01 02 06 27
43'	0,09 05 34 26 41	0,00 01 02 06 17
44'	0,09 06 36 32 58	0,00 01 02 06 07
45'	0,09 07 38 39 05	

a) $f(x)$ sinus funksiyaning jadvalda berilgan oltmishli kasr qiymatlarini o'nli kasrlarga aylantiring va ularni biror jadval yoki EHMning ko'rsatishi bilan solishtiring;

b) grafigi to'rt $(x_i, f(x_i))$ tugunli siniq chiziqdan iborat $f(x)$ funksiya ifodasini tuzing.

- 7.84.** Ulug'bek taqvim (kalendari) bo'yicha o'rtacha hijriy-qamariy 1 yil $\approx 354,3671$ kun, o'rtacha milodiy 1 yil $\approx 365,25$ kun. Hijriy-qamariyning madxali (H_0 hisob boshi) milodiy 622- yilning 16- iyuliga to'g'ri keladi (37- rasm). Milodiydan hijriy yilga va aksincha, o'tish tenglamasini tuzing.

Funksiya grafigini yasang:

$$7.85. \quad y = \begin{cases} 3, & \text{agar } x \leq -4, \\ |x^2 - 4|x| + 3|, & \text{agar } -4 < x \leq 4, \\ 3 - (x - 4)^2, & \text{agar } x > 4. \end{cases}$$



37- rasm.

$$7.86. y = \begin{cases} 8 - (x + 6)^2, & \text{agar } x < -6, \\ |x^2 - 6|x| + 8|, & \text{agar } -6 \leq x < 5, \\ 3, & \text{agar } x \geq 5. \end{cases}$$

$$7.87. y = \begin{cases} x^3, & \text{agar } x \leq -1, \\ \frac{1}{x}, & \text{agar } -1 < x < 0, \\ x^2, & \text{agar } x \geq 0. \end{cases}$$

$$7.88. y = \begin{cases} x^2, & \text{agar } x \leq -1, \\ 2x - 1, & \text{agar } -1 < x \leq 1, \\ \sqrt{x}, & \text{agar } x > 1. \end{cases}$$

3. Funksiya grafigini nuqtalar bo'yicha yasash. Biror X sonli oraliqda berilgan $y = f(x)$ sonli funksiya grafigi Γ ni «nuqtalar usuli» bilan yasash uchun X oraliqdan argumentning bir necha x_1, x_2, \dots, x_n qiymati tanlanadi, funksiyaning ularga mos $f(x_1), \dots, f(x_n)$ qiymatlari hisoblanadi, koordinatalar tekisligida $M(x_1; f(x_2)), \dots, M(x_n; f(x_n))$ nuqtalar belgilanadi va bu nuqtalar ustidan silliq chiziq o'tkaziladi. Bu chiziq $f(x)$ funksiya grafigini taqriban ifodalaydi.

Agar ordinata o'qiga parallel bo'lgan har qanday to'g'ri chiziq Γ chiziqni ko'pi bilan bitta nuqtada kessa, u holda Γ chiziq biror $f(x)$ funksiyaning grafigi bo'ladi. Shunga ko'ra $x^2 + y^2 = R^2$ aylana hech qanday funksiyaning grafigi emas, chunki Oy o'qiga parallel bo'lgan $x = a$ to'g'ri chiziq (38- a rasm) bu aylanani bittadan ortiq (aynan ikkita M va N) nuqtalarda kesadi, demak, $x = a$ qiymatga y ning ikki qiymati to'g'ri keladi, ya'ni $y = \pm\sqrt{R^2 - x^2}$, $-R \leq x \leq R$.

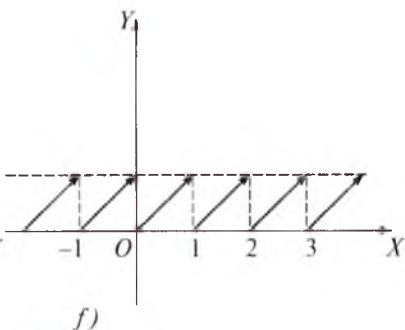
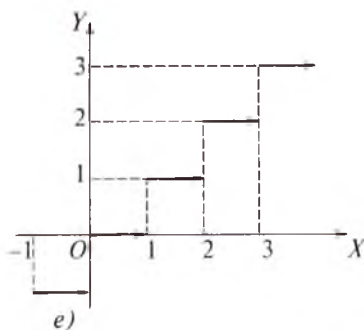
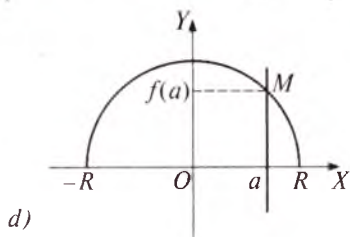
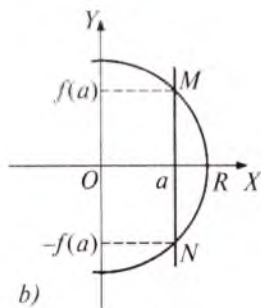
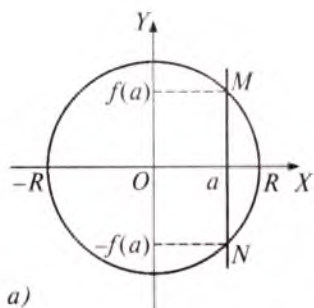

38- rasm.

Shu kabi $y = \pm\sqrt{R^2 - x^2}$, $0 \leq x \leq R$ va $y = \pm\sqrt{R^2 - x^2}$, $-R \leq x \leq 0$ yarim aylana ham funksiya grafiği emas. Lekin $y = \sqrt{R^2 - x^2}$, $-R \leq x \leq R$ yarim aylana shu ifodali funksiya-ning grafiği (37- b, d rasm) (Γ – yunoncha gamma, bosh harf).

Funksiya grafiği uzilishga ega bo'lishi mumkin. $y = [x]$ va $y = \{x\}$ funksiyalar grafiğlari uzilishlidir (38- e, f rasm). Bu yerda $y = [x] - x$ ning butun qismi va $y = \{x\} - x$ ning kasr qismi. Ulardan birinchisi pog'onasimon joylashgan birlik kesmalardan,

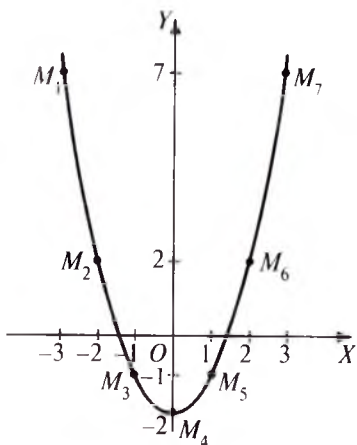

39- rasm.

$M_7(3; 7)$ nuqtalarni belgilab, ularni qo'l bilan tutashtirib silliq chiziq chizamiz (39- rasm).

ikkinchisi esa $y = x + n$ ($n \leq x < n + 1 | n \in \mathbb{Z}$) to'g'ri chiziqlardan iborat.

1- misol. $y = x^2 - 2$ funksiya grafigi eskizini chizamiz, bunda $-3 \leq x \leq 3$ (eskiz — xomaki, asbob yordamisiz chizilgan chizma).

Yechish. Argumentning $x = -3; -2; -1; 0; 1; 2; 3$ qiymatlarini tanlaylik. $f(x)$ qiymatlarini hisoblaymiz: $f(-3) = f(3) = 9 - 2 = 7$, $f(-2) = f(2) = 4 - 2 = 2$, $f(-1) = f(1) = -1$, $f(0) = -2$. Koordinatalar tekisligida $M_1(-3; 7)$, $M_2(-2; 2)$, $M_3(-1; -1)$, $M_4(0; -2)$, $M_5(1; -1)$, $M_6(2; 2)$,



Mashqlar

7.89. Quyidagi funksiyalar grafiglarini «nuqtalar bo'yicha» yasang:

a) $y = x^2 + 2$;

b) $y = x^3 - 1$;

d) $y = x^4 - 1$;

e) $y = \frac{1}{x} - 1$;

f) $y = \frac{4}{x^2 + 1}$;

g) $y = \frac{x-1}{x^2-1}$;

h) $y = |x - 2|$;

i) $y = |x^2 - 1|$;

j) $y = |x| - |x - 1|$;

k) $y = x - |x|$;

l) $y = |x - |x + 2||$;

m) $y = 3x^2 - 4x$.

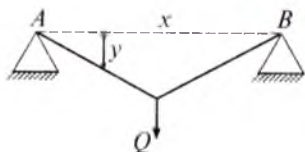

40- rasm.

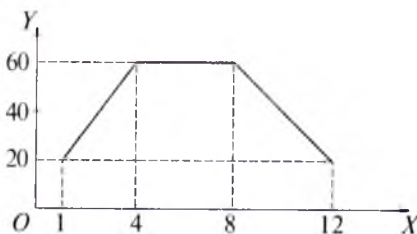

41- rasm.

7.90. 7.79- misolda berilgan funksiyaning grafigini yasang.

7.91. Ikkala uchi A va B nuqtalarda erkin joylashtirilgan $AB = k$ uzunlikdagi sterjen uning o'rtasiga qo'yilgan Q kattalikdagi yukning ta'siri ostida egiladi (40- rasm). A uchidan x uzoqlikdagi y egilish ushbu formulalar bo'yicha aniqlanadi:

$$y = \begin{cases} \frac{Qk^3}{48EI} \left(\frac{3x}{k} - \frac{4x^3}{k^3} \right), & 0 \leq x \leq \frac{k}{2}, \\ \frac{Qk^3}{48EI} \left(\frac{3(k-x)}{k} - \frac{4(k-x)^3}{k^3} \right), & \frac{k}{2} \leq x \leq k; \end{cases}$$

E, I – doimiy sonlar;

a) $x = \frac{k}{6}; \frac{k}{4}; \frac{k}{2}; \frac{3k}{4}$ nuqtalardagi egilishni toping. Nima uchun $x = \frac{k}{2}$ da ikkala ifoda bir xil natijani beradi?

b) $Q = 48, k = 1$ bo'lgan hol uchun (1) formula grafigi eskizini chizing va y bo'yicha egilishning $x = \frac{1}{6}; \frac{1}{4}; \frac{1}{2}$ dagi qiymatini toping.

7.92. 41- rasmda x (kg) o'g'itga bog'liq holda $y = f(x)$ (kg) hosilning olinishi grafik tasvirlangan. 1) x ning qanday qiymatlarida hosil muttasil oshgan («limitik soha»), qachon va qanday miqdorda eng yuqori bo'lgan? 2) Qachon o'g'it har qancha berilsa ham, hosil o'zgarmagan («statsionar, ya'ni turg'unlik sohasi»)? 3) Qachondan boshlab o'g'itning ortiqcha berilganligi va natijada hosilning pasayishi kuzatilgan («ingibatsiya sohasi», lot. *inhibare* – susaytirish)? 4) $x = 2; 4; 5; 6; 8; 10$ (kg) o'g'it berilib, qancha hosil olingan? 5) Agar 28 (kg) hosil rejaning 36% ni tashkil etsa, reja bo'yicha qancha hosil olinishi ko'zda tutilgan?

7.93. O'zbek olimi N. M. Muhitdinov yer ostidan gazni qazib olish maqsadida depressiya 2, 5, 10 yil davomida doimiy ΔP kg/sm² holatida tutib turilganda gaz-suv chegarasining yer ustiga tomon R m ga ko'chishini tekshirgan va asarlaridan birida $R = f(\Delta P)$ bog'lanishni grafik tasvirlagan (42- rasm).

R, m

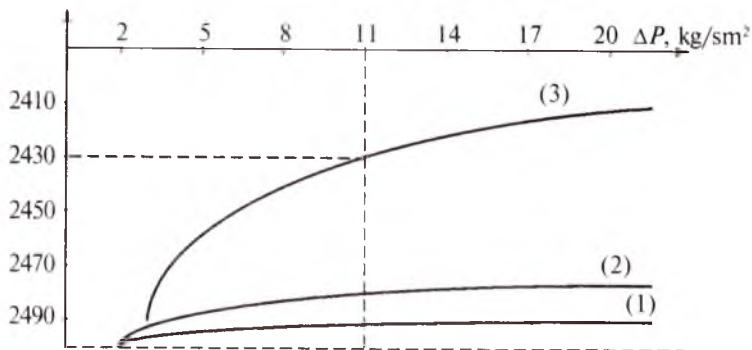

42- rasm.

Agar depressiya $\Delta P = 11 \text{ kg/sm}^2$ bo'lsa, 10 yil qazib olishlardan so'ng ((3) grafik) gaz-suv chegarasi qancha siljiydi? 5 yilda-chi ((2) grafik)? 2 yilda-chi ((1) grafik)? Agar $\Delta P = 2; 8; 14 \text{ (kg/sm}^2\text{)}$ darajada tutib turilsa-chi? (lot. *depressus* – pastlashtirish; gazni qazib olish uchun uni o'rab turgan suv bosimini kamaytirish.)

4. Funktsiyalar ustida amallar. $D(f)$ to'plamda berilgan $f(x)$ va $D(g)$ to'plamda berilgan $g(x)$ funksiyalarning yig'indisi deb $D(\varphi) = D(f) \cap D(g)$ to'plamda berilgan yangi $\varphi(x) = f(x) + g(x)$ funksiyaga aytiladi.

1- misol. $f = x^2 - 4$, $-3 \leq x \leq 2$ va $g = x + 2$, $-2 \leq x \leq 3$ funksiyalar yig'indisi $\varphi(x) = (x^2 - 4) + (x + 2)$, $-2 \leq x \leq 2$ funksiyadan iborat. Uning grafigini chizishda f va g funksiyalar mos ordinatalarini qo'shishdan foydalanish mumkin (43- rasm).

$f(x)$ va $g(x)$ funksiyalarning ko'paytmasi $D(\varphi) = D(f) \cap D(g)$ to'plamda berilgan $\varphi(x) = f(x) \cdot g(x)$ funksiyadan iborat.

$\frac{1}{g(x)}$ funksiya $D(g)$ to'plamning $g(x) \neq 0$ bo'lgan barcha sonlarida aniqlangan. $f(x) \cdot \frac{1}{g(x)}$ (qisqacha yozuvda $f \cdot \frac{1}{g}$) funksiya f va g funksiyalar bo'linmasi deb ataladi. Uni $\frac{f}{g}$ orqali belgilaymiz.

2- misol. $f(x) = (x-1)^3 - 3$ berilgan. $\frac{4}{f^2-3}$ funksiya ifodasi

$\frac{4}{((x-1)^3-3)^2-3}$ ko'rinishda yoziladi: $\frac{4}{f^2-3} = \frac{4}{((x-1)^3-3)^2-3}$.

f va g sonli funksiyalar berilgan va $E(f) \subset D(g)$ bo'lsin. f va g funksiyalar *kompozitsiyasi* deb $D(f)$ da berilgan va har qaysi $x \in D(f)$ songa $g(f(x))$ sonni mos qo'yuvchi yangi $F(x)$ funktsiyaga aytiladi (lot. *compositio* – tuzish). F funksiya $g \circ f$ orqali ham belgilanadi: $(g \circ f)(x) = g(f(x))$. Kompozitsiya ifodasini tuzish uchun $g(x)$ dagi x o'rniga f funksiya ifodasi qo'yiladi.

3- misol. $f(x) = x^3 - 2$ va $g(x) = \frac{1}{x}$ funksiyalarning $g \circ f$ va $f \circ g$ kompozitsiyalarini tuzing.

Yechish. 1) $g \circ f = g(f(x)) = \frac{1}{x^3-2}$;

2) $f \circ g = f(g(x)) = \left(\frac{1}{x}\right)^3 - 2$.

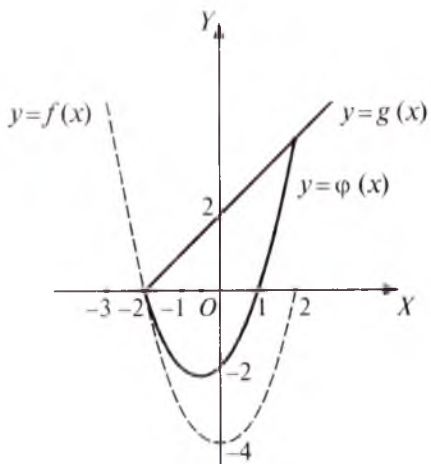

43- rasm.



Mashqlar

7.94. $f(x) = \frac{x-1}{x+1}$ bo'lsa, $f\left(\frac{1}{x^2}\right)$ ni toping.

7.95. $f(x) = \sqrt{x^3 - 1}$ bo'lsa, $f(\sqrt[3]{x^2 + 1})$ ni toping.

7.96. $f(x) = \frac{x^2}{\sqrt{1+x^2}}$ bo'lsa, $f(\operatorname{tg}x)$ ni toping.

7.97. $f\left(\frac{3x-1}{x+2}\right) = \frac{x+1}{x-1}$ bo'lsa, $f(x)$ ni toping.

7.98. $f(x) + 2f\left(\frac{1}{x}\right) = x$ bo'lsa, $f(x)$ ni toping.

7.99. $(x-1)f(x) + f\left(\frac{1}{x}\right) = \frac{1}{x-1}$ bo'lsa, $f(x)$ ni toping.

7.100. $f(x) + xf\left(\frac{x}{2x-1}\right) = 2$ bo'lsa, $f(x)$ ni toping.

7.101. $2f\left(\frac{x}{x-1}\right) - 3f\left(\frac{3x-2}{2x+1}\right) = \frac{13x-4}{2x-3x^2}$ bo'lsa, $f(x)$ ni toping.

2- §. Grafiklarni almashtirish

1. Geometrik almashtirishlarda nuqta koordinatalarining o'zgarishi.

1) Siljitish. Biror l to'g'ri chiziqda koordinatalar sistemasi o'rnatilgan va uning boshi O nuqtada bo'lsin (44- rasm). l ning har qaysi nuqtasi a birlik qadar siljitsin. Agar bunda $a > 0$ bo'lsa, siljitish O nuqtaga nisbatan musbat yo'nalishda, $a < 0$ da manfiy yo'nalishda bajariladi, $a = 0$ da nuqta o'z joyidan siljimaydi. Agar x koordinatali $M = M(x)$ nuqta $M'(x')$ nuqtaga o'tgan bo'lsa, M' nuqta koordinatasi $x' = x + a$ formula bo'yicha aniqlanadi. M nuqta M' ning *asli* (*proobrazi*), M' esa M ning *nusxasi* (*obrazi*) deyiladi. Masalan, $M(3)$ nuqta $a = 4$ birlik siljitsa, $x' = x + a = 3 + 4 = 7$ koordinatali $M'(7)$ nuqtaga ko'chadi.



44- rasm.

2) Cho'zish. l to'g'ri chiziqda $M(x)$ nuqta O koordinata boshidan k marta uzoqlashtirilib (yoki O ga yaqinlashtirilib), $M'(x')$ nuqtaga o'tkazilgan bo'lsin. M' nuqta koordinatasi $x' = kx$ formula bo'yicha hisoblanadi. Agar bunda $k > 0$ bo'lsa, M' nuqta M bilan birgalikda O nuqtaning bir tomonida, $k < 0$ da M' nuqta O ning ikkinchi tomonida joylashadi, $|k| < 1$ da $x = OM$ kesma k marta qisqaradi, $|k| > 1$ da esa k marta cho'ziladi, $k = 1$ da M va M' nuqtalar ustma-ust tushadi, $k = -1$ da ular O nuqtaga nisbatan simmetrik joylashadi.

3) Parallel ko'chirishda xOy koordinata tekisligidagi barcha nuqtalar bir xil yo'nalishda bir xil masofaga ko'chadi (45- rasm). Chunonchi, $O(0; 0)$ koordinata boshi $L(a; b)$ nuqtaga ko'chirilgan bo'lsa, $M(x; y)$ nuqta $M'(x'; y')$ ga ko'chadi va bunda $MM' = OL$, $MM' \parallel OL$ bo'ladi.

Chizmaga qaraganda to'g'ri burchakli $\triangle MKM' = \triangle OaL$ va $MK = Oa = a$, $KM' = aL = b$, $x' - x = a$, $y' - y = b$. Bulardan M' nuqta koordinatalarini hisoblash uchun ushbu formulalar hosil qilinadi:

$$x' = x + a, \quad y' = y + b.$$

4) Gomotetiya (yunoncha *homos* – bir xil, teng; *thetos* – o'rinlashgan). Gomotetiyada tekislikdagi har qaysi $M(x; y)$ nuqta OM nurda yotuvchi va koordinatalari $x' = kx$, $y' = ky$ bo'lgan $M'(x'; y')$ nuqtaga o'tadi, bunda O – gomotetiya markazi, k – gomotetiya koeffitsiyenti. $k = -1$ da gomotetiya O nuqtaga nisbatan ($x' = -x$; $y' = -y$) *markaziy simmetriya* bo'ladi (yunoncha *symmetriya* – moslik, muvofiqlik).

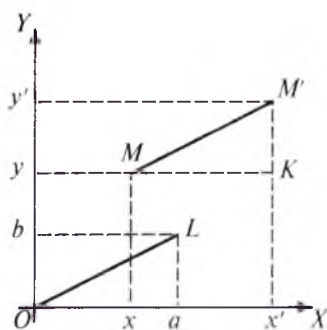

45- rasm.

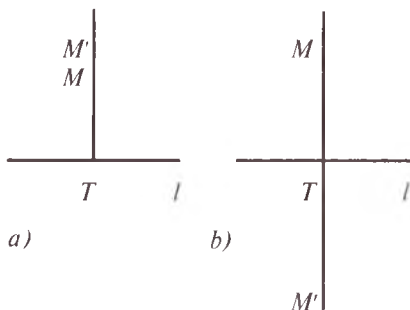

46- rasm.

5) Tekislikni to'g'ri chiziqqa nisbatan cho'zish. Tekislikdagi biror M nuqtadan l to'g'ri chiziqqa MT perpendikular tushirilgan (lot. *perpendicularis* – tik) (46-*a, b* rasm) va M nuqta MT da yotuvchi $M'(x'; y')$ nuqtaga o'tkazilgan bo'lsin, bunda $M'T = k \cdot MT$. Agar bunda $k > 0$ bo'lsa, M va M' lar birgalikda l ning bir tomonida, $k < 0$ bo'lsa, uning turli tomonlarida joylashadi. Jumladan, Ox o'qqa nisbatan k koeffitsiyent bilan cho'zish $M(x; y)$ nuqtani koordinatalari $x' = x, y' = ky$ bo'lgan $M'(x'; y')$ nuqtaga, Oy o'qqa nisbatan cho'zish esa koordinatalari $x' = kx, y' = y$ bo'lgan nuqtaga o'tkazadi. To'g'ri chiziqqa nisbatan $k = -1$ koeffitsiyent bilan cho'zish shu to'g'ri chiziqqa nisbatan simmetriyadir. Jumladan, Ox o'qqa nisbatan simmetriya $M(x; y)$ nuqtani $M'(x; -y)$ nuqtaga, Oy o'qqa nisbatan simmetriya esa $M'(-x; y)$ nuqtaga o'tkazadi.



Mashqlar

- 7.102.** Parallel ko'chirishda koordinatalar boshi $L(-1; 4)$ nuqtaga ko'chgan. $M(-2; 6), N(0; -8)$ nuqtalarning obrazlarini va $P'(-1; 5), Q'(1; 3)$ nuqtalarning proobrazlarini toping.
- 7.103.** Parallel ko'chirishda $K(-3; 4)$ nuqta $L(-2; 2)$ nuqtaga ko'chsin. $M(-2; 6), N(0; -5)$ nuqtalarning obrazlarini va $A(-4; 3), B(4; -2)$ nuqtalarning proobrazlarini toping.
- 7.104.** φ orqali koordinatalar boshini $L(-3; 1)$ nuqtaga o'tkazuvchi parallel ko'chirish, g orqali ordinatalar o'qiga nisbatan simmetriya belgilangan bo'lsin. $\varphi \circ \gamma$ va $\gamma \circ \varphi$ almashtirishlarning formulalarini yozing. Hosil bo'ladigan

almashtirishlar bir xilmi? Shu almashtirishlardagi $K(5; -1)$, $M(0; -3)$ nuqtalarning obrazlarini va $P(-3; 4)$, $Q(-2; -2)$ nuqtalarning proobrazlarini toping.

7.105. f orqali ordinatalar o'qidan $k = 3$ koeffitsiyent bilan cho'zish, φ orqali koordinatalar boshini $L(3; 2)$ nuqtaga o'tkazadigan parallel ko'chirish belgilangan bo'lsin. $f \circ \varphi$ va $\varphi \circ f$ almashtirishlar ifodasini yozing. $f \circ \varphi$ almashtirishda $ABCD$ to'g'ri to'rtburchak qanday shaklga o'tadi? Bunda $A(1; 0)$, $B(6; 0)$, $C(6; 2)$, $D(1; 2)$.

7.106. $x' = k(x - a) + a$, $y' = k(y - b) + b$ almashtirish $L(a; b)$ nuqtaga nisbatan gomotetiya ekani isbot qilinsin.

7.107. Quyidagi formulalar bilan berilgan geometrik almash-tirishlarni tavsiflang (arabcha *tavsif* – tushuntirib yozish, xarakteristika):

$$\text{a) } \begin{cases} x' = 3(x - 6) + 4, \\ y' = 3(y + 1) - 5; \end{cases} \quad \text{b) } \begin{cases} x' = 5x - 1, \\ y' = 5y + 4. \end{cases}$$

2. Funksiya grafigini almashtirish. 1) xOy koordinatalar sistemasi unda chizilgan $y = f(x)$ funksiya grafigi bilan birgalikda $x = a$, $y = b$ birlik qadar *parallel ko'chirilgan* bo'lsin (45- rasm, $a = 4$, $b = 7$). $O(0; 0)$ koordinatalar boshi $L(a; b)$ nuqtaga ko'chadi. f grafikning obrazi yangi $X'LY'$ sistemada $y' = f(x')$ orqali ifodalanadi. Bu oldingi xOy sistemaga nisbatan $y = f(x - a) + b$ ga mos. Haqiqatan, biror $M(x_0; y_0)$ nuqta $f(x)$ grafikda yotgan va $y_0 = f(x_0)$ bo'lsa, uning obrazi, ya'ni $M'(x_0 + a; y_0 + b)$ nuqta $y = f(x - a) + b$ grafigida yotadi. Chunki bu munosabatdagi x va y lar o'rniga $x_0 + a$, $y_0 + b$ lar qo'yilsa, $y_0 + b = f(x_0 + a - a) + b$ yoki $y_0 = f(x_0)$ tenglik qaytadan hosil bo'ladi. Shu kabi, agar M' nuqta $y = f(x - a) + b$ grafigida yotgan bo'lsa, uning proobrazi $y = f(x)$ grafigida yotadi.

1 - misol. 47- rasmda $y = f(x)$ funksiya grafigini $x = 4$ va $y = 7$ birlik parallel ko'chirish orqali $y = f(x - 4) + 7$ funksiya grafigini yasash tasvirlangan.

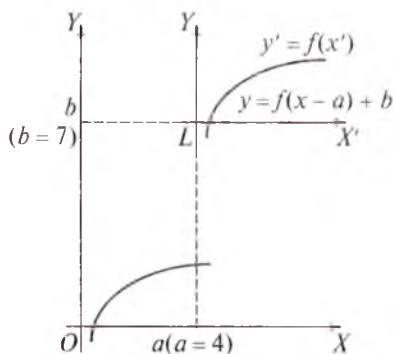

47- rasm.

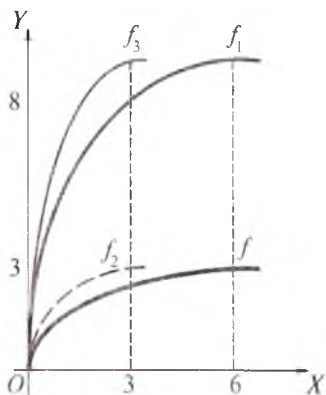

48- rasm.

2) Cho'zish. $M(x_0; y_0)$ nuqta f grafikda yotgan bo'lsin: $y_0 = f(x_0)$.

Agar f grafik absissalar o'qidan $l \neq 0$ koefitsiyent marta, ordinatalar o'qidan $k \neq 0$ marta cho'zilsa, $y = lf\left(\frac{x}{k}\right)$ funksiya grafigi hosil bo'ladi. Unda $M(x_0; y_0)$ nuqtaning obrazi bo'lgan $M'(kx_0; ly_0)$ nuqta yotadi: $ly_0 = lf\left(\frac{kx_0}{k}\right)$ yoki $y_0 = f(x_0)$. Aksincha, M' nuqta $y = lf\left(\frac{x}{k}\right)$ da yotgan bo'lsa, M nuqta f grafikda yotadi. Demak, Ox o'qqa nisbatan l marta, Oy o'qqa nisbatan k marta cho'zish orqali $y = f(x)$ funksiya grafigidan $y = lf\left(\frac{x}{k}\right)$ funksiya grafigi hosil qilinadi.

To'g'ri chiziqqa nisbatan -1 ga teng koefitsiyent bilan cho'zish shu to'g'ri chiziqqa nisbatan simmetriya bo'lganidan, $y = -f(x)$ funksiya grafigi $y = f(x)$ grafigini absissalar o'qiga nisbatan simmetrik almashtirishdan, $y = f(-x)$ grafigi f grafikni ordinatalar o'qiga nisbatan, $y = -f(-x)$ grafik esa f ni koordinatalar boshiga nisbatan simmetrik almashtirish bilan hosil qilinadi.

2 - misol. f funksiya grafigi bo'yicha $f_1(x) = 3f(x)$, $f_2(x) = f(2x)$, $f_3(x) = 3f(2x)$ funksiyalar grafiklarini yasaymiz (48- rasm).

Yechish. f_1 funksiya grafigi f grafikni Ox lar o'qidan $l = 3$ koefitsiyent bilan cho'zish, ya'ni f dagi nuqtalar ordinatalarini 3

marta cho'zish orqali, f_2 grafik f grafikni Oy o'qidan $k = \frac{1}{2}$ marta cho'zish (ya'ni 2 marta qisqartirish, qisish), buning uchun f nuqtalari absissalarini 2 marta qisqartirish orqali, f_3 grafigi esa f grafigini absissalar o'qidan $l = 3$ marta uzoqlashtirish va ordinatalar o'qiga $k = \frac{1}{2}$ koeffitsiyent bilan yaqinlashtirish orqali yasaladi.

3 - misol. $f(x)$ funksiyaning grafigidan foydalanib, $y = 5f(3x + 6) + 1$ funksiya grafigini yasash tartibini keltiring.

Y e c h i s h . Funksiyani $y = 5f(3(x + 2)) + 1$ ko'rinishda yoza-miz.

1) Koordinatalar boshini $L(-2; 0)$ ga o'tkazadigan parallel ko'chirishni; 2) Oy o'qidan $k = 3$ marta cho'zishni; 3) absissalar o'qidan $l = 5$ koeffitsiyent bilan cho'zishni; 4) absissalar o'qidan $b = 1$ birlik yuqoriga parallel ko'chirishni bajaramiz.

I z o h . Funksiya ifodasini boshqa ko'rinishga keltirmay, ishni $f(3x + 6)$ grafigini yasash bilan boshlash ham mumkin edi.



Mashqlar

7.108. 49- rasmda tasvirlangan $y = f(x)$ funksiya grafigidan foydalanib, quyidagi funksiyalar grafiklarini yasang:

a) $g(x) = f(x) - 3$;

b) $g(x) = f(x - 2)$;

d) $g(x) = -f(x)$;

e) $g(x) = f(-x)$;

f) $g(x) = -f(-x)$;

g) $g(x) = 3f(x)$;

h) $g(x) = 3f(x - 2)$;

i) $g(x) = f(3x) + 1$;

j) $g(x) = f\left(\frac{x}{2}\right)$;

k) $g(x) = 3f\left(\frac{x}{2}\right)$;

l) $g(x) = 0,5f(x)$;

m) $g(x) = 0,5f(2x)$;

n) $g(x) = 3f(2x - 4) + 5$;

o) $g(x) = |f(x - 3)|$;

p) $g(x) = -3f(2x - 4) - 5$;

q) $g(x) = f(3 - x)$.

7.109. $y = |x|$ funksiyaning grafigidan foydalanib, quyidagi funksiyalarning grafiklarini yasang:

a) $y = |x| - 3$;

b) $y = |x + 1| - 3$;

d) $y = -|x|$;

f) $y = |-2 - 3x|$;

h) $y = \left| \frac{x}{2} \right|$;

j) $y = 3|x - 2| - 4$;

l) $y = 3|2x - 4| + 5$;

n) $y = |3 - x|$;

e) $y = |x|$;

g) $y = 3|x|$;

i) $y = 3\left| \frac{x}{2} \right|$;

k) $y = -2|-3x| - 4$;

m) $y = -5|2x - 4| + 1$;

o) $y = |2 - 4x| + 3$.

3. Chizikli funksiya grafigi. 1) l to'g'ri chiziq koordinatalar tekisligining birinchi va uchinchi choraklari va $O(0; 0)$ koordinatalar boshidan o'tsin (50- rasm). Unda O nuqtaga nisbatan simmetrik $M(x_0; y_0)$, $M'(-x_0; -y_0)$ nuqtalarni va $N(1; k)$ nuqtani belgilaymiz. $\alpha = \angle lOx$ - to'g'ri chiziq bilan absissalar o'qining musbat yo'nalishi orasidagi o'tkir burchak, $k = \frac{y_0}{x_0} = \operatorname{tg}\alpha > 0$ to'g'ri chiziqning burchak koeffitsiyenti. $\triangle OAN$ va $\triangle OB'M'$ larning o'xshashligidan $\frac{k}{l} = \frac{y_0}{x_0}$ yoki $y_0 = kx_0$ bo'ladi. Shu kabi $\triangle OAN$ va $\triangle OB'M'$ larning o'xshashligidan $y_0 = kx_0$, $k > 0$ ni olamiz.

l to'g'ri chiziqqa ordinatalar o'qiga nisbatan simmetrik bo'lgan l' to'g'ri chiziqni qaraylik. P nuqta M ga, P' nuqta M' ga simmetrik bo'lsin. $\frac{k}{l} = \frac{y_0}{-x_0} = \frac{-y_0}{x_0}$ proporsiyaga ega bo'lamiz. $y_0 = -kx_0$ bo'ladi, bunda $k = -\operatorname{tg}\alpha$, $\alpha = l'Ox$ - o'tmas burchak.

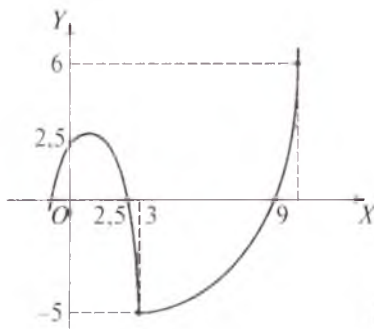

49- rasm.

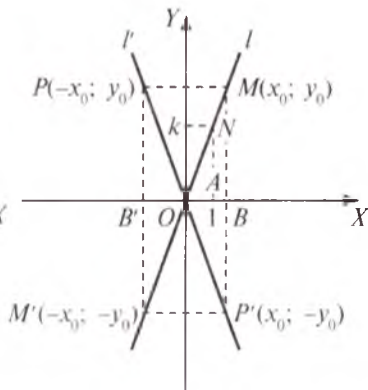

50- rasm.

Shunday qilib, koordinatalar boshidan o'tuvchi va $k > 0$ da absissalar o'qining musbat yo'nalishi bilan o'tkir burchak, $k < 0$ da esa o'tmas burchak tashkil etuvchi to'g'ri chiziq $y = kx$ funksiyaning grafigidan iborat.

2) $y = kx + l$ chiziqli funksiya grafigi $y = kx$ funksiya grafigini ordinata o'qi bo'yicha l birlik parallel ko'chirish bilan hosil qilinadi. Bundan bir xil k koeffitsiyentli chiziqli funksiyalarning grafiglari o'zaro parallel bo'lishi kelib chiqadi.

Koordinata tekisligidagi $L(a; b)$ nuqta orqali burchak koeffitsiyenti k ga teng bo'lgan faqat bitta to'g'ri chiziq o'tadi, bunda k — oldindan berilgan son. Uning tenglamasi $y = k(x - a) + b$. Chiziq $y = kx$ funksiya grafigini parallel ko'chirish bilan hosil qilinadi, bunda $O(0; 0)$ koordinatalar boshi $L(a; b)$ nuqtaga o'tadi.

To'g'ri chiziqning burchak koeffitsiyentini topish uchun to'g'ri chiziqqa qarashli $M(x_1; y_1)$ va $N(x_2; y_2)$ nuqtalarning koordinatalari to'g'ri chiziq tenglamasiga qo'yilib, hosil bo'ladigan sistema yechiladi:

$$\begin{cases} y = k(x - x_1) + y_1, \\ y = k(x - x_2) + y_2, \end{cases} \Rightarrow k = \frac{y_2 - y_1}{x_2 - x_1}, \quad (1)$$

$M(x_1; y_1)$ va $N(x_2; y_2)$ nuqtalardan o'tuvchi to'g'ri chiziq tenglamasi $y = k(x - x_1) + y_1$ munosabatga $k = \frac{y_2 - y_1}{x_2 - x_1}$ ifodani qo'yish bilan hosil qilinadi:

$$y = \frac{y_2 - y_1}{x_2 - x_1} (x - x_1) + y_1 \quad \text{yoki} \quad \frac{y - y_1}{y_2 - y_1} = \frac{x - x_1}{x_2 - x_1}, \quad (2)$$

bunda $x_1 \neq x_2, y_1 \neq y_2$.

1- misol. $M(2; -3)$ nuqtadan o'tuvchi va $y = 5x - 6$ to'g'ri chiziqqa parallel bo'lgan to'g'ri chiziq tenglamasini tuzamiz.

Yechish. Izlanayotgan to'g'ri chiziq $y = 5x - 6$ to'g'ri chiziqqa parallel, demak, uning burchak koeffitsiyenti ham $k = 5$. To'g'ri chiziq $M(2; -3)$ nuqtadan o'tadi. Demak, uning tenglamasi $y = 5(x - 2) - 3$ yoki $y = 5x - 13$.

2- misol. $M(-2; -3)$ va $N(4; -1)$ nuqtalardan o'tuvchi to'g'ri chiziqning tenglamasini tuzamiz.

Yechish. (2) formuladan foydalanamiz:

$$\frac{y-(-3)}{-1-(-3)} = \frac{x-(-2)}{4-(-2)}, \text{ bundan } y = \frac{1}{3}x - 2\frac{1}{3}.$$



Mashqlar

- 7.110.** Koordinatalar boshi va M nuqta ustidan o'tuvchi to'g'ri chiziq tenglamasini tuzing:
a) $M(3; -4)$; b) $M(0; -3)$; d) $M(3; 0)$; e) $M(2; 5)$.
- 7.111.** Chizikli funksiyalarning grafiklarini yasang:
a) $y = x - 2$; b) $y = -x + 3$; d) $y = 4x - 2$; e) $y = -2x - 5$.
- 7.112.** $M(-2; 7)$ nuqtadan o'tuvchi va burchak koeffitsiyenti $k = 3$ bo'lgan to'g'ri chiziq tenglamasini tuzing va chizing.
- 7.113.** M nuqtadan o'tuvchi va burchak koeffitsiyenti k bo'lgan to'g'ri chiziq tenglamasini tuzing:
a) $M(-2; -1)$, $k = 2$; b) $M(0; -4)$, $k = -3$;
d) $M(-1; -2)$, $k = \frac{1}{3}$; e) $M(5; 2)$, $k = \frac{1}{3}$.
- 7.114.** $A(-4; 6)$ nuqtadan o'tib, $y = 3x + 5$ to'g'ri chiziqqa parallel bo'lgan to'g'ri chiziq tenglamasini tuzing.
- 7.115.** Uchlari $A(-2; 0)$, $B(7; -2)$, $C(4; 5)$ nuqtalarda bo'lgan ABC uchburchakning:
a) tomonlarining tenglamalarini;
b) medianalarining tenglamalarini tuzing.
- 7.116.** $y = |x + 2| + |x - 5|$ funksiya grafigini yasang.
- 7.117.** a) $y \leq -2x + 7$ va $y \geq x + 6$; b) $y \geq 4x - 3$ va $y \leq -2x + 2$ lar o'rinli bo'lgan sohalarni tasvirlang.

4. Kvadrat funksiya grafigi. $y = x^2$ funksiya bizga quyi sinflardan tanish. Uning grafigi, uchi koordinatalar boshi $O(0; 0)$ da va tarmoqlari yuqoriga yo'nalgan parabola (51- rasm). $y = ax^2$ funksiya grafigi esa x^2 parabolani absissalar o'qidan a koeffitsiyent bilan cho'zish ($|a| > 1$ da) yoki qisish ($|a| < 1$ da) orqali hosil qilinadi. $a < 0$ da $y = ax^2$ parabola Ox o'qiga nisbatan simmetrik akslanadi. Ixtiyoriy $a \neq 0$ da $y = ax^2$ funksiya grafigi paraboladan iborat.

$y = ax^2 + bx + c$, $a \neq 0$ funksiya grafigini yasash maqsadida ifodani $y = a\left(x + \frac{b}{2a}\right)^2 + \frac{4ac-b^2}{4a}$ yoki $y = a(x\alpha)^2 + b$ ko'rinishga keltiramiz, bunda $-\alpha = \frac{b}{2a}$, $\beta = \frac{4ac-b^2}{4a}$. Bundan ko'rinadiki, $y = ax^2 + bx + c$ funksiyaning grafigi $y = ax^2$ parabolani Oy o'qqa nisbatan α qadar va Ox o'qqa nisbatan β qadar parallel ko'chirish orqali hosil qilinadi, bunda parabolaning $O(0; 0)$ uchi $L(\alpha; \beta)$ nuqtaga o'tadi.

Mashqlar

7.118. Funksiyalarning grafiglarini yasang:

- | | |
|--------------------------|---------------------------|
| a) $y = x^2 + 6x - 20$; | b) $y = -x^2 - 6x + 20$; |
| d) $y = 3x^2 - 6x + 4$; | e) $y = 2x - x^2$; |
| f) $y = 6 - 4x - x^2$; | g) $y = 2x^2 + 8x - 1$. |

7.119. A , B , C nuqtalardan o'tuvchi parabolani yasang va tenglamasini tuzing:

- | | | |
|-----------------|--------------|-------------|
| a) $A(2; -1)$, | $B(1; 3)$, | $C(0; 2)$; |
| b) $A(1; 1)$, | $B(2; 3)$, | $C(0; 2)$; |
| d) $A(-2; 1)$, | $B(5; -1)$, | $C(4; 2)$; |
| e) $A(2; 0)$, | $B(3; -6)$, | $C(4; 1)$. |

7.120. $y = ax^2$ paraboladagi $M(x_0; y_0)$ nuqtadan k burchak koeffitsiyentli kesuvchi to'g'ri chiziq o'tkazilgan. Parabola va to'g'ri chiziqning ikkinchi kesishish nuqtasi x_1 absissa-

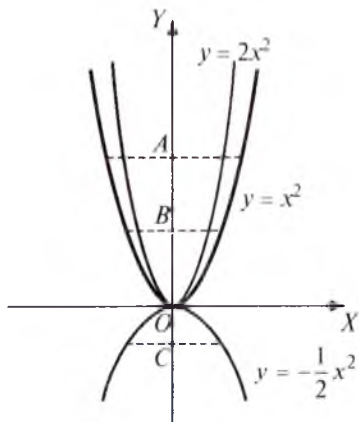

$$OA = 2OB$$

$$OC = -\frac{1}{2}OB$$

51- rasm.

sini x_0 va k orqali toping. k ning qanday qiymatida kesuvchi M nuqtada parabolaga urinuvchi bo'lib qoladi?

7.121. x_0 absissali nuqtada $y = ax^2 + b$ parabolaga urinuvchi to'g'ri chiziqning tenglamasini tuzing, bunda:

a) $a = -1$, $b = 1$, $x_0 = 3$; b) $a = 4$, $b = 2$, $x_0 = 2$.

5. Kasr-chiziqli funksiya grafigi. Ikki chiziqli funksiyaning nisbatidan iborat

$$y = \frac{ax+b}{cx+d} \quad (1)$$

kasr-chiziqli funksiyaning qaraymiz. Uning grafigi to'g'ri chiziq yoki giperbola bo'lishi mumkin:

1) agar $c=0$, $d \neq 0$ bo'lsa, (1) munosabat $y = \frac{a}{d}x + \frac{b}{d}$ chiziqli funksiya aylanadi, uning grafigi to'g'ri chiziqdan iborat;

2) $c \neq 0$, $\frac{a}{c} = \frac{b}{d} = m$ bo'lsa, $y = \frac{mcx+md}{cx+d} = m$ ga ega bo'lalimiz. Bu holda (1) funksiya grafigi Ox o'qqa parallel bo'lgan va $M(-\frac{d}{c}; m)$ nuqtasi chiqarib tashlangan $y=m$ to'g'ri chiziq bo'ladi;

3) $a \neq 0$, $\frac{a}{c} \neq \frac{b}{d}$. Oldin $\frac{ax+b}{cx+d}$ kasrdan butun qism ajratamiz:

$$\frac{ax+b}{cx+d} = \frac{a}{c} + \frac{b-\frac{ad}{c}}{cx+d} = \frac{a}{c} + \frac{bc-ad}{c^2 \cdot \frac{d}{x+\frac{c}{d}}} = \beta + \frac{k}{x-\gamma}, \text{ bunda}$$

$$\beta = \frac{a}{c}, \quad k = \frac{bc-ad}{c^2}, \quad \gamma = -\frac{d}{c}. \quad (2)$$

Bundan ko'rinadiki, $y = \frac{x+b}{cx+d}$ funksiya grafigi $y = \frac{k}{x}$ funksiya grafigi (giperbola)ni parallel ko'chirishlar bilan hosil qilinadi, bunda koordinatalar boshi $L(\gamma; \beta)$ nuqtaga o'tadi. γ , β va k lar (2) formulalar bo'yicha topiladi.

1- misol. $y = \frac{2x+14}{x+5}$ funksiya grafigini yasang (52- rasm).

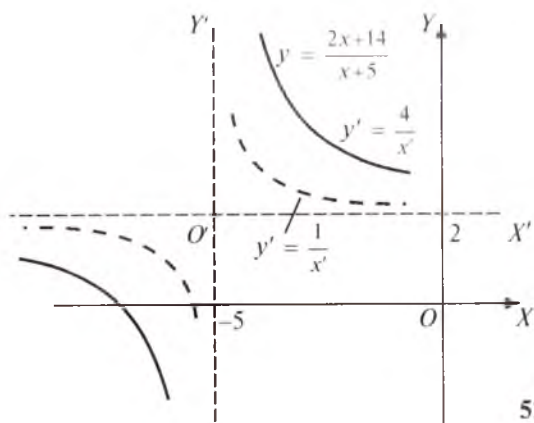

52- rasm.

Yechish. Kasrdan butun qismini ajratamiz: $\frac{2x+14}{x+5} = 2 + \frac{4}{x+5}$, unda $k=4$, $\gamma=-5$, $\beta=2$. $O'(-5; 2)$ nuqtadan yordamchi $O'x'$, $O'y'$ koordinatalar o'qlarini o'tkazamiz. Ularda $y = \frac{1}{x}$ funksiya grafigini, so'ng $y = \frac{k}{x}$ funksiya grafigini yasaymiz. Bu grafik xOy koordinatalar sistemasida $y = \frac{2x+14}{x+5}$ ning grafigi bo'ladi.



Mashqlar

7.122. Funksiyalarning grafiglarini yasang:

- a) $y = \frac{2x-5}{x+1}$; b) $y = \frac{-3x+2}{2x-3}$; d) $y = \frac{4x+1}{2x-3}$;
 e) $y = \frac{3x+4}{2x-1}$; f) $y = \frac{x+9}{-3x+1}$; g) $y = \frac{6x+1}{4x-2}$.

7.123. A , B , C nuqtalar ustidan o'tuvchi $y = \frac{ax+b}{cx+d}$ funksiya grafigini yasang:

- a) $A(-2; 0)$, $B(1; 4)$, $C(0; 2)$;
 b) $A(1; -3)$, $B(3; 2)$, $C(-1; 3)$;
 d) $A(4; -3)$, $B(2; 1)$, $C(3; -4)$;
 e) $A(-5; 1)$, $B(-2; 3)$, $C(-1; 5)$.

6. Ifodasi modul ishorasiga ega funktsiyalarning grafigi.

$$1) |f(x)| = \begin{cases} f(x), & \text{agar } f(x) \geq 0 \text{ bo'lsa,} \\ -f(x), & \text{agar } f(x) < 0 \text{ bo'lsa,} \end{cases} \text{ ekanini biz bilamiz.}$$

Bundan ko'rinadiki, $|f|$ grafigini yasash uchun oldin f grafigini yasash, so'ng uning $y \geq 0$ yarim tekislikdagi qismini o'z joyida qoldirib, $y < 0$ yarim tekislikdagi qismini esa Ox o'qqa nisbatan simmetrik akslantirish kerak. 53- rasmda $y = |x^2 - 2|$ grafigini $y = x^2 - 2$ grafigidan foydalanib yasash tasvirlangan.

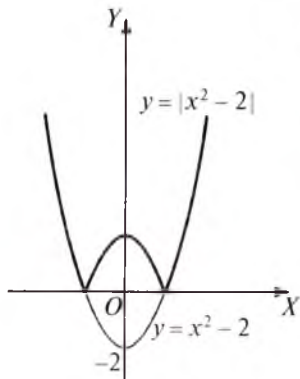

53- rasm.

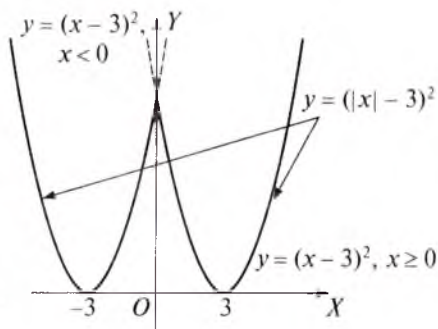

54- rasm.

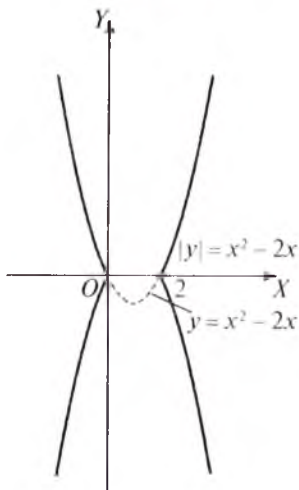

55- rasm.

$$2) f(|x|) = \begin{cases} f(x), & x \geq 0, \\ f(-x), & x < 0 \end{cases} \text{ mu-}$$

nosabatdan ko'rinadiki, $y = f(|x|)$ grafigi $f(x)$ funktsiya grafigining $x \geq 0$ yarim tekisligidagi qismi hamda uning Oy o'qiga nisbatan simmetrik aksidan tashkil topadi. 54- rasmda $y = (|x| - 3)^2$ grafigini $y = (x - 3)^2$ grafigidan foydalanib yasash tasvirlangan.

3) 55- rasmda $|y| = x^2 - 2x$ bog'lanish grafigini $y = x^2 - 2x$ grafi-gidan foydalanib yasash tasvirlangan.

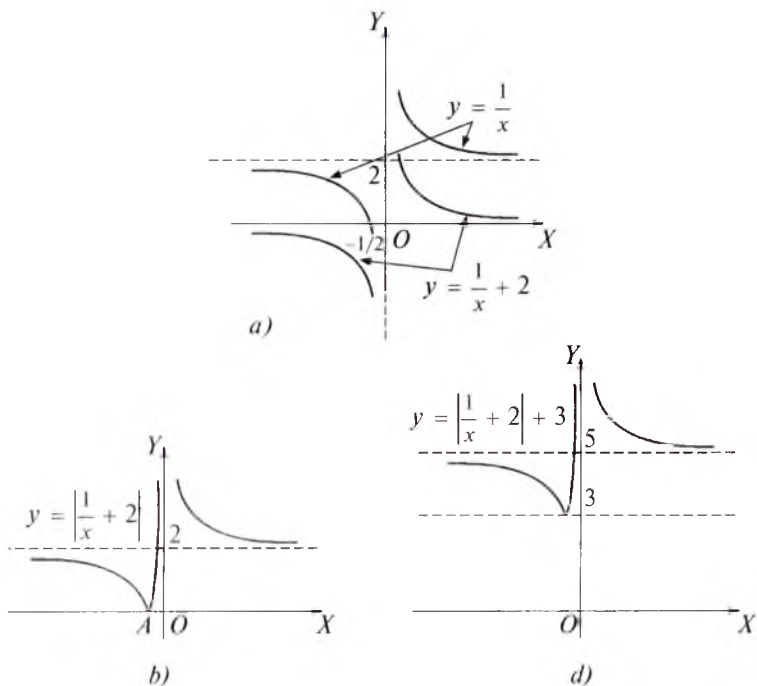

56- rasm.

1- misol. $y = \left| \frac{1}{x} + 2 \right| + 3$ funksiya grafigini yasaymiz.

Yechish. a) Dastavval $y = \frac{1}{x}$ funksiya grafigini, so'ngra shu grafik bo'yicha $y = \frac{1}{x} + 2$ grafigini yasaymiz (56- a rasm);

b) x ning har qanday qiymatida $y = \left| \frac{1}{x} + 2 \right| \geq 0$. Shunga ko'ra, $y = \frac{1}{x} + 2$ grafining $-\frac{1}{2} < x < 2$ da Ox o'qi ostida turgan qismini Ox o'qiga nisbatan simmetrik akslantiramiz (56- b rasm). Bunda $x = -\frac{1}{y}$ qiymat $y=0$, ya'ni $\frac{1}{x} + 2 = 0$ bo'yicha topiladi;

d) talab qilinayotgan $y = \left| \frac{1}{x} + 2 \right| + 3$ grafikni yasash uchun $y = \left| \frac{1}{x} + 2 \right|$ grafigi 3 birlik yuqoriga parallel ko'chiriladi (56- d rasm).



Mashqlar

7.124. Funktsiyalarning grafiklarini yasang:

a) $y = |x^2 - 3x + 2|$;

b) $y = x^2 - 2|x| - 3$;

d) $y = |x^2 - 3x| + 2$;

e) $y = ||x - 2| - 3x|$;

f) $y = |x - 1| + |x - 3|$;

g) $y = \left| \frac{x+4}{x+1} \right|$;

h) $y = \frac{|x|-4}{|x|-2}$;

i) $y = \left| x + \frac{1}{x} - 1 \right|$;

j) $y = \frac{|x|-4}{x+1}$;

k) $y = \frac{x-3}{|x+1|}$;

l) $y = \frac{1}{|3x-1|+|x|}$;

m) $0 y = \frac{1}{|x|+|x-2|-3}$.

7.125. Quyidagi tengliklarni qanoatlantiruvchi $M(x; y)$ nuqtalar to'plamini yasang:

a) $x - 2|x| = y - 2|y|$;

b) $x + 2|x| = y - 2|y|$;

d) $x - 2|x| = y + 2|y|$;

e) $x + 2|x| = y + 2|y|$;

f) $x - 2|x| = y - 2|y|$;

g) $[x] = 2[y]$.

7.126. Quyidagi tengliklarni qanoatlantiruvchi $M(x; y)$ nuqtalar to'plamini toping:

a) $|y| = x^2 - 3x + 2$;

b) $|y| = \frac{x+1}{x-2}$;

d) $|y| = \frac{|x|+2}{|x|-2}$;

e) $|y| = \frac{|x+2|}{|x-2|}$.

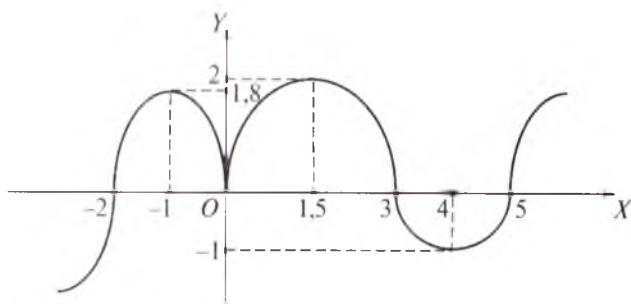

57- rasm.

7.127. 57- rasmda $y = f(x)$ funksiya grafigi tasvirlangan. Undan foydalanib quyidagi funksiyalar grafiglarini yasang:

a) $y = |f(x)|$;

b) $y = -|f(x)|$;

d) $y = f(|x|)$;

e) $y = |f(|x|)|$;

f) $y = -|f(|x|)|$;

g) $y = -|f(-|x|)|$;

h) $y = |f(-|x|)|$;

i) $y = |-f(-|x|)|$.

7.128. 57- rasmda tasvirlangan $f(x)$ funksiya grafigidan foydalanib, ushbu tengliklarni qanoatlantiruvchi $M(x; y)$ nuqtalar to'plamlarini tasvirlang:

a) $|y| = f(x)$;

b) $|y| = f(-x)$;

d) $|y| = -f(x)$;

e) $|y| = -|f(x)|$;

f) $|y| = f(|x|)$;

g) $|y| = -f(|x|)$.

Bu tengliklar funksiyani ifodalaydimi?

7. Darajali funksiya grafigi. α haqiqiy son va ixtiyoriy x

musbat son uchun x^α soni har vaqt aniqlangan bo'ladi. $x < 0$ va

$\alpha = \frac{m}{n}$ bo'lganda $y < x^\alpha$ funksiya aniqlanmagan. Biz $x > 0$ hol

bilan shug'ullanamiz. Har qanday α haqiqiy son uchun $(0; +\infty)$

musbat sonlar to'plamida aniqlangan $y = x^\alpha$ funksiya mavjud.

Unga α ko'rsatkichli *darajali funksiya* deyiladi, bunda x –

darajaning asosi. Darajali funksiya $x = 1$ da $y = 1$ dan iborat *doimiy*

funksiyaga aylanadi. Darajali funksiyaning xossalari haqiqiy

ko'rsatkichli darajaning xossalariga o'xshashdir. Ulardan ayrim-

larini esga keltiramiz.

1. Darajali funksiya barcha $x > 0$ qiymatlarda aniqlangan.

2. Darajali funksiya $(0; +\infty)$ da musbat qiymatlar qabul qiladi.

3. $\alpha > 0$ da darajali funksiya $(0; 1)$ oraliqda monoton kamayadi,

$[1; +\infty)$ da monoton o'sadi.

Darajali funksiya o'zining aniqlanish sohasida bir qiymatli,

faqat α ko'rsatkich juft maxrajli qisqarmaydigan kasr son bo'lgan

holdagina ikki qiymatli bo'ladi. Ko'p hollarda darajali funksiyaning

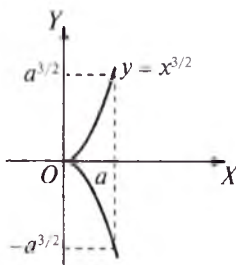

58- rasm.

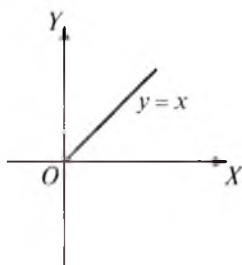

59- rasm.

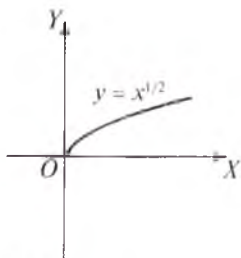

60- rasm.

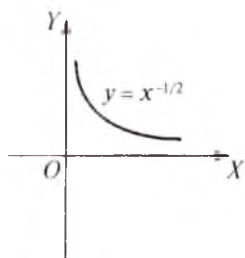

61- rasm.

ikki qiymatidan manfiy bo'lmagan (arifmetik) qiymati tanlab olinadi.

$x > 0$ da α daraja ko'rsatkichi turlicha bo'lgan darajali funksiya grafiklari 58–61- rasmlarda tasvirlangan. 58- rasmda $y = x^{3/2}$ yarim kubik parabola tasvirlangan.



Mashqlar

7.129. Funksiyalar grafiklarining eskizlarini chizing:

a) $y = x^{1/5}$;

b) $y = x^{-1/5}$;

d) $y = x^5$;

e) $y = x^{-5}$;

f) $y = |x^{1/5}|$;

g) $y = (x - 1)^{1/5}$;

h) $y = (x + 1)^{1/5}$;

i) $y = |x - 1|^{1/3}$;

j) $y = |x - 1|^{1/3} + 1$;

k) $y = |81x - 243|^{1/4}$;

l) $y = (2x)^3$;

m) $y = (2x)^{1/3}$.

7.130. $f(x) = \sqrt{x^4} - x$ ning $x = -2; -1; 0; 1; 2; 3; 4; -8; 8$ ga mos qiymatlarini toping va grafigini yasang.

7.131. R radiusli doiraga ichki chizilgan teng yonli uchburchakning yuzini uning balandligining funksiyasi sifatida ifodalang.

7.132. Yuzi S ga teng bo'lgan uchburchak yuzini uning: 1) asosi uzunligining; 2) balandligi uzunligining funksiyasi sifatida ifodalang.

7.133. Muntazam oltiburchak yuzini uning tomoni uzunligining funksiyasi sifatida ifodalang.

3- §. Funksiyalarni tekshirish

1. Juft va toq funksiyalar. Agar X to'plamning har qanday x elementi uchun $-x \in X$ bo'lsa, X to'plam $O(0; 0)$ nuqtaga nisbatan simmetrik to'plam deyiladi. Masalan, $(-\infty; +\infty)$, $[-2; 2]$, $(-3; 3)$, $(-8; -2) \cup [2; 8)$ to'plamlarning har biri $O(0; 0)$ nuqtaga nisbatan simmetrik to'plamdir. $(-3; 2)$ to'plam esa $O(0; 0)$ nuqtaga nisbatan simmetrik bo'lmagan to'plamdir.

Aniqlanish sohasi $O(0; 0)$ nuqtaga nisbatan simmetrik bo'lgan to'plamda $y = f(x)$ funksiya uchun $\forall x \in B(f)$ larda $f(-x) = f(x)$ tenglik bajarilsa, $f(x)$ funksiya *juft funksiya*, $f(-x) = -f(x)$ tenglik bajarilganda esa *toq funksiya* deyiladi. Masalan, $f(x) = 2x^2 + 3$ – juft funksiya, chunki $f(-x) = 2(-x)^2 + 3 = 2x^2 + 3 = f(x)$. Shuningdek, $y = |x|$, $y = x^4$ lar ham juft funksiyalardir. $(-x)^5 = -x^5$, demak, $y = x^5$ – toq funksiya. Umuman, x^{2n} , $n \in \mathbb{N}$, funksiyalar juft, x^{2n-1} , $n \in \mathbb{N}$, funksiyalar toq funksiyalardir. Ta'riflarga qaraganda toq funksiya grafigi koordinata boshiga nisbatan, juft funksiya grafigi esa ordinatalar o'qiga nisbatan simmetrik joylashadi. Juft va toq funksiya aniqlanish sohasi koordinata boshiga nisbatan simmetrik joylashadi.

1-misol. $f(x) = x^7$ funksiyani $-4 \leq x \leq 5$ va $-6 \leq x \leq 6$ da simmetriklikka tekshiring.

Ye ch ish. Funksiya berilgan $[-4; 5]$ oraliq koordinatalar boshiga nisbatan simmetrik emas. Demak, funksiya ham bu sohada simmetrik emas. $[-6; 6]$ oraliqda $O(0; 0)$ ga nisbatan simmetrik. $(-x)^7 = -x^7$. Demak, bu sohada funksiya toq.

Funksiyalarni juft-toqlikka tekshirishda quyidagi ta'kidlardan ham foydalanamiz:

a) $f(x)$ funksiya $D(f)$ da, $g(x)$ funksiya $D(g)$ da aniqlangan bo'lsin. Agar umumiy $x \in D(f) \cap D(g)$ aniqlanish sohasida $f(x)$ va $g(x)$ funksiya bir vaqtda juft (yoki toq) bo'lsa, ularning $(f+g)(x)$ yig'indisi ham juft (toq) bo'ladi. Haqiqatan, $(f+g)(-x) = f(-x) + g(-x) = f(x) + g(x) = (f+g)(x)$; $(f+g)(-x) = f(-x) + g(-x) = -f(x) - g(x) = -(f+g)(x)$;

b) ikkita juft (toq) funksiya ko'paytmasi juft funksiya, toq va juft funksiyalar ko'paytmasi esa toq funksiya bo'ladi. Haqiqatan, f va g funksiyalar juft bo'lsa, $(fg)(-x) = f(-x)g(-x) = f(x)g(x) = (fg)(x)$. Qolgan hollar ham shu kabi isbotlanadi.

2- misol. $f(x) = a$, $a \in R$ doimiy funksiya juft funksiyadir. Chunki $y = a$ funksiya grafigi Ox o'qiga parallel va Oy o'qiga nisbatan simmetrik joylashgan to'g'ri chiziqdan iborat. Shunga ko'ra, agar f funksiya juft (toq) bo'lsa, af funksiya ham juft (toq) funksiya bo'ladi. Agar f va g funksiyalar juft (toq) bo'lsa, $af + bg$ funksiya ham juft (toq) funksiya bo'ladi.

3- misol. $x^6 - 2x^2 + 6$ – juft funksiya, chunki x^6 , $2x^2$ va 6 lar juft, $x^5 - 2x$ – toq funksiya, chunki x^5 va $2x$ – toq; $(x-2)^2$ na toq, na juft, chunki uning yoyilmasi bir turli bo'lmagan (ya'ni juft va toq) funksiyalar yig'indisi $x^2 - 4x + 4$ dan iborat. Keyingi xulosani yana quyidagicha ham isbotlash mumkin:

$$(-x-2)^2 = (x+2)^2 \neq (x-2)^2.$$

4- misol. $\frac{x^2-4}{x^6-2x^4+7}$ funksiya $f = x^2 - 4$ va $g = \frac{1}{x^6-2x^4+7}$ juft funksiyalarning ko'paytmasi sifatida juft funksiyadir.

Agar X sonli to'plam koordinatalar boshiga nisbatan simmetrik bo'lsa, u holda shu to'plamda berilgan f funksiyani

$\varphi = \frac{f(x)+f(-x)}{2}$ juft funksiya va $\psi = \frac{f(x)-f(-x)}{2}$ toq funksiyalar-ning yig'indisi shaklida ifodalash mumkin. Haqiqatan,

$$\varphi + \psi = \frac{(f(x)+f(-x))+(f(x)-f(-x))}{2} = f(x).$$



Mashqlar

Funksiyani juftlikka tekshiring (7.134–7.138):

7.134. a) $f(x) = 19$; d) $g(x) = (2 - 3x)^3 + (2 + 3x)^3$;

b) $\varphi(x) = 0$; e) $h(x) = (5x - 2)^4 + (5x + 2)^4$.

7.135. a) $f(x) = (x + 3)|x - 1| + (x - 3)|x + 1|$;

b) $\varphi(x) = (x + 5)|x - 3| - (x - 5)|x + 3|$;

d) $g(x) = \frac{|x-7|}{x+1} + \frac{|x+7|}{x-1}$; e) $h(x) = \frac{|x-4|}{x+2} - \frac{|x+4|}{x-2}$.

7.136. a) $f(x) = (x + 2)(x + 3)(x + 4) - (x - 2)(x - 3)(x - 4)$;

b) $\varphi(x) = (x - 5)^8(x + 7)^{11} + (x + 5)^8(x - 7)^{11}$;

d) $g(x) = (x - 6)^9(x + 3)^5 + (x + 6)^9(x - 3)^5$;

e) $h(x) = (x^2 - 3x + 5)(x^3 - 8x^2 + 2x - 1) - (x^2 + 3x + 5) \times (x^3 + 8x^2 + 2x + 1)$.

7.137. a) $f(x) = \frac{x^3 - 2x^2}{x+1} - \frac{x^3 + 2x^2}{x-1}$;

b) $\varphi(x) = \frac{x^5 - 2x^2 + 3}{x-4} + \frac{x^5 + 2x^2 + 3}{x+4}$;

d) $g(x) = \frac{(x-1)^5}{(3x+4)^3} + \frac{(x+1)^5}{(3x-4)^3}$;

e) $h(x) = \frac{(x-2)^3(x+1)^5(x-5)^7}{2x+1} + \frac{(x+2)^3(x-1)^5(x+5)^7}{2x-1}$.

7.138. a) $f(x) = 8^{x^2}$;

b) $f(x) = 4,3^x$;

d) $f(x) = x^3 + 3x^2 - 5$;

e) $f(x) = 5x^4 - 4x^3 + 3x^2 + 1$.

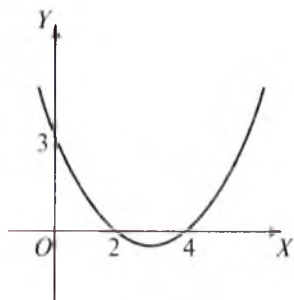

62- rasm.

Funksiyani juft va toq funksiyalarning yig'indisi shaklida tasvirlang (7.139–7.140):

7.139. a) $f(x) = |x + 1| \cdot x^2 - 1$;

b) $f(x) = |2x - 3| + x^2 - 1$;

d) $\varphi(x) = (x + 3)|x - 1| + |x + 1|x$;

e) $g(x) = |x - 1||x + 1||x + 2|x + 3|x|(x - 1)$.

7.140. a) $f(x) = \frac{(x-2)^2(x+3)^3}{2x+1} - \frac{(x+2)^2}{x-1}$;

b) $f(x) = 2(x - 2)|x + 3| + \frac{5|x| + 4x^2}{x - 1}$;

d) $\varphi(x) = 3|x - 2|(x - 1) + \frac{x^2 - 2x + 1}{|x + 1|}$;

e) $g(x) = 3|x^2 - 4x + 1| + |x^2 - x| + 8x^2$.

7.141. Grafigi 62- rasmda tasvirlangan parabolaning tenglamasini tuzing va uni juft-toqlikka tekshiring.

7.142. Qanday shartlarda f funksiya grafigi:

a) $x = a$ to'g'ri chiziqqa nisbatan simmetrik bo'ladi?

b) $M(a; b)$ nuqtaga nisbatan simmetrik bo'ladi?

2. Funksiya qiymatlarining o'zgarishi. Agar X to'plamda x argument qiymatining ortishi bilan f funksiyaning qiymatlari ham ortsa (kamaysa), funksiya shu to'plamda *o'suvchi (kamayuvchi) funksiya* deyiladi. Boshqacha aytganda, $x_1 \in X$, $x_2 \in X$, $x_1 < x_2$ qiymatlarda $f(x_1) < f(x_2)$ bo'lsa, f funksiya X to'plamda *o'suvchi*, agar $f(x_1) > f(x_2)$ bo'lsa, funksiya *kamayuvchi bo'ladi* (63- a, b rasm).

Agar $x_1 \in X$, $x_2 \in X$, $x_1 < x_2$ da $f(x_1) \leq f(x_2)$ (mos ravishda $f(x_1) \geq f(x_2)$) bo'lsa, f funksiyaga X to'plamda *noqat'iy o'suvchi* (mos ravishda *noqat'iy kamayuvchi*) deyiladi. Bunday funksiyalar grafigi o'sish (kamayish) oraliqlaridan tashqari gorizontallik oraliqlariga ham ega bo'lishlari mumkin (64- a, b rasm).

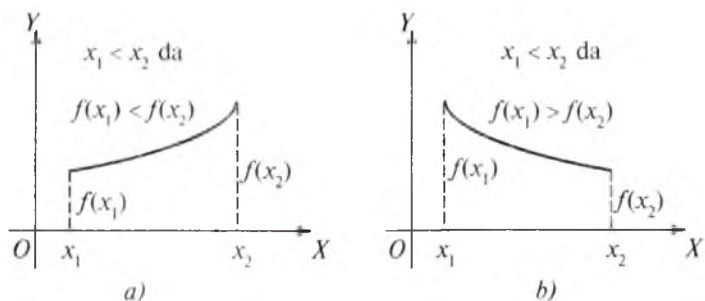

63- rasm.

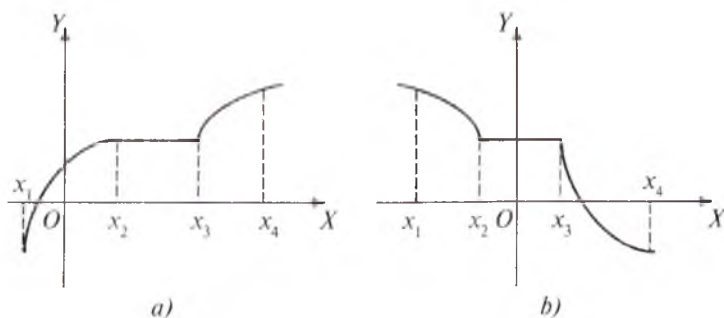

64- rasm.

X to'plamda o'suvchi yoki kamayuvchi funksiyalar shu to'plamda *monoton*, noqat'iy o'suvchi yoki noqat'iy kamayuvchi funksiyalar shu X to'plamda *noqat'iy monoton funksiyalar* deyiladi.

$y = x^2$ funksiya $(-\infty; 0]$ oraliqda monoton, chunki unda kamayuvchi, $[0; +\infty)$ oraliqda ham monoton, unda o'sadi, lekin $(-\infty; +\infty)$ da monoton emas, chunki unda kamayuvchi ham emas, o'suvchi ham emas.

Funksiyalarning monotonligini isbotlashda quyidagi ta'kidlardan foydalanish mumkin:

1) agar X to'plamda f funksiya o'suvchi bo'lsa, har qanday c sonida $f + c$ funksiya ham X da o'sadi;

2) agar f funksiya X to'plamda o'suvchi va $c > 0$ bo'lsa, cf funksiya ham X da o'sadi;

3) agar f funksiya X to'plamda o'ssa, $-f$ funksiya unda kamayadi;

4) agar $f(f(x) \neq 0)$ funksiya X to'plamda o'ssa va o'z ishorasini saqlasa, $1/f$ funksiya shu to'plamda kamayadi;

5) agar f va g funksiyalar X to'plamda o'suvchi bo'lsa, ularning $f + g$ yig'indisi ham shu to'plamda o'sadi;

6) agar f va g funksiyalar X to'plamda o'suvchi va nomanfiy bo'lsa, ularning fg ko'paytmasi ham shu to'plamda o'suvchi bo'ladi;

7) agar f funksiya X to'plamda o'suvchi va nomanfiy, n esa natural son bo'lsa, f^n funksiya ham shu to'plamda o'suvchi bo'ladi;

8) agar f funksiya X to'plamda o'suvchi, g funksiya esa f funksiyaning $E(f)$ qiymatlari to'plamida o'suvchi bo'lsa, bu funksiyalarning $g \circ f$ kompozitsiyasi ham X da o'suvchi bo'ladi.

Bu ta'kidlar tengsizliklarning xossalari va funksiyalarning o'sishi va kamayishi ta'riflaridan kelib chiqadi (6- bob, 3- §, 5- b. ga ham qarang). Masalan, $x_1 \in X$, $x_2 \in X$, $x_1 < x_2$ da $f(x_1) < f(x_2)$, $g(x_1) < g(x_2)$ bo'lsin. Tengsizliklarning e) xossasiga muvofiq $f(x_1) + g(x_1) < f(x_2) + g(x_2)$ ga ega bo'lamiz. Bu esa $f + g$ funksiyaning X da o'suvchi bo'lishini ko'rsatadi.

1- misol. $f = \frac{1}{x^6 + 4x^3 + 1}$ funksiyaning $[0; +\infty)$ yarim o'qda kamayuvchi ekanini isbot qilamiz.

Yechish. $y = x$ funksiya $[0; +\infty)$ yarim o'qda nomanfiy va o'suvchi. 2) va 7) ta'kidlarga ko'ra, x^6 va $4x^3$ funksiyalar ham shu yarim o'qda o'sadi. U holda 1) va 5) ta'kidlarga ko'ra $x^6 + 4x^3 + 1$ funksiya $[0; +\infty)$ da o'sadi, 4) ta'kidga ko'ra $\frac{1}{x^6 + 4x^3 + 1}$ funksiya kamayadi.

Agar funksiya $[a; x_1]$ da o'sib, $[x_1; b]$ da kamayuvchi bo'lsa, uning x_1 dagi $f(x_1)$ qiymati $[a; b]$ dagi qolgan barcha qiymatlaridan katta bo'ladi (65- a rasm). Masalan, $y = -(x - x_3)^2 + y_1$ funksiya $(-\infty; +\infty)$ da eng katta qiymatga erishadi, $y_{\text{eng katta}} = y_1$ (65- e rasm). Aksincha, $y = (x - x_2)^2 + y_0$ funksiya

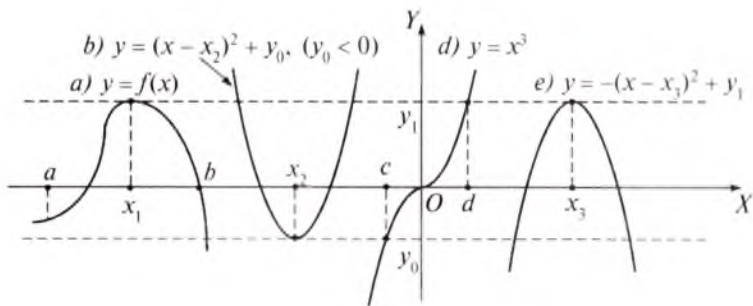

65- rasm.

$(-\infty; x_2]$ oraliqda kamayib, $[x_2; +\infty)$ da o'sadi (65- b rasm). Uning x_2 dagi y_0 qiymati $(-\infty; +\infty)$ dagi qolgan barcha qiymatlaridan kichik: $y_{\text{eng kichik}} = y_0$. 65- a rasmda grafigi $y = y_0$ va $y = y_1$ to'g'ri chiziqlar bilan chegaralangan $f(x)$ funksiya tasvirlangan. 65- b rasmda parabolaning tarmoqlari yuqoriga cheksiz yo'nalgan: $y = +\infty$ yoki $y \rightarrow +\infty$. Bu funksiya yuqoridan chegaralangan emas, quyidan $y = y_0$ to'g'ri chiziq bilan chegaralangan. Shu kabi, 65- e rasmda tasvirlangan funksiya yuqoridan $y = y_1$ bilan chegaralangan, $y = x^3$ funksiya esa (65- d rasm) yuqoridan ham, quyidan ham chegaralangan emas. Lekin $[c; d]$ oraliqda bu funksiya $y = y_1$ va $y = y_0$ to'g'ri chiziqlar bilan chegaralangan bo'ladi.

Agar shunday M haqiqiy soni mavjud bo'lib, barcha $x \in X$ sonlari uchun $f(x) \geq M$ (mos ravishda $f(x) \leq M$) tengsizlik bajarilsa, f funksiya X to'plamda quyidan chegaralangan (yuqoridan chegaralangan) deyiladi. Agar funksiya X to'plamda ham quyidan, ham yuqoridan chegaralangan bo'lsa, u shu to'plamda chegaralangan deyiladi.

2- misol. $y = -x^2$ funksiyanı qaraymiz. Barcha $x \in (-\infty; +\infty)$ sonlari uchun $-x^2 \leq 0$ bo'lgani uchun bu funksiya $(-\infty; +\infty)$ oraliqda yuqoridan chegaralangan.

3- misol. $y = x^2$ funksiya $(-\infty; +\infty)$ oraliqda quyidan chegaralangan funksiya, chunki barcha $x \in (-\infty; +\infty)$ sonlari uchun $y(x) = x^2 \geq 0$ tengsizlik bajariladi.

4- misol. $y = x$ funksiya $(0; 1)$ oraliqda quyidan 0 soni bilan, yuqoridan esa 1 soni bilan chegaralangan ekanini ko'rish qiyin emas. Demak, bu funksiya $(0; 1)$ oraliqda chegaralangandir.

Agar ixtiyoriy M haqiqiy soni uchun, shunday bir $x \in X$ son topilib, $f(x) < M$ ($f(x) > M$) tengsizlik bajarilsa, $f(x)$ funksiya X to'plamda quyidan (mos ravishda, yuqoridan) chegaralanmagan deyiladi.

Agar f funksiya X to'plamda yo quyidan, yo yuqoridan, yoki har ikki tomondan chegaralanmagan bo'lsa, bu funksiya X to'plamda chegaralanmagan funksiya deyiladi.



Mashqlar

7.143. Funksiyalarning chegaralanganligini isbot qiling:

a) $y = \frac{1}{1+x^2}$; b) $y = \frac{2}{4+x^2}$.

7.144. Funksiyalarning chegaralanmaganligini isbot qiling:

a) $y = \frac{1}{1-x^2}$; b) $y = \frac{1}{(x-1)^2}$.

7.145. a) $y = \frac{5}{2x+1}$ funksiya $(-\infty; -0,5)$ da kamayishini;

b) $y = \frac{4}{2-x}$ funksiya $(2; +\infty)$ da o'sishini;

d) $y = \frac{21x-9}{3x-1}$ funksiya $(-\infty; \frac{1}{3})$ da o'sishini;

e) $y = \frac{4x+31}{x+7}$ funksiya $(-7; +\infty)$ da kamayishini isbotlang.

7.146. a) $y = 3x^2 - 4x + 7$ funksiya $(-\infty; \frac{2}{3}]$ da kamayishini;

b) $y = 5x^2 + 6x + 19$ funksiya $(-\infty; 0,6]$ da o'sishini;

d) $y = 3\sqrt{4x+1} - 1$ funksiya $[-0,25; +\infty)$ da kamayishini;

e) $y = 2 + \sqrt{3-5x}$ funksiya $(-\infty; 0,6]$ da kamayishini isbotlang.

7.147. a) $y = x^3 - 3x$ funksiya $[1; +\infty)$ da o'sishini;

b) $y = 12x - x^3$ funksiya $[2; +\infty)$ da kamayishini;

d) $y = 0,5x^2 - 2\sqrt{x}$ funksiya $[1; +\infty)$ da o'sishini va $[0; 1]$ da kamayishini;

e) $y = \sqrt{x} - 2x^2$ funksiya $[0; 0,25]$ da o'sishini va $[0,25; +\infty)$ da kamayishini isbotlang.

7.148. $f(x) = x^2$ funksiya berilgan. Argumentning har qanday x_1 va x_2 qiymatlarida $f\left(\frac{x_1+x_2}{2}\right) \leq \frac{f(x_1)+f(x_2)}{2}$ bo'lishini isbotlang.

7.149. $f(x) = \sqrt{x}$ funksiya berilgan. Argumentning har qanday x_1 va x_2 qiymatlarida $f\left(\frac{x_1+x_2}{2}\right) \leq \frac{f(x_1)+f(x_2)}{2}$ bo'lishini isbotlang.

7.150. $f(x) = x^2 - 4x + 4$ va $g(x) = \frac{a+1}{x+3}$ funksiyalar berilgan:

a) $f(x)$ funksiya $[2; +\infty)$ da o'sishini isbotlang;

b) $g(x)$ funksiya $[2; +\infty)$ da kamayishini isbotlang;

d) a ning $f(3) = g(3)$ bo'ladigan barcha qiymatlarini toping;

e) $(x-2)^2 = \frac{6}{x+3}$ tenglamani $[2; +\infty)$ oraliqda yeching.

7.151. $f(x) = (x-3)^2$ va $g(x) = \frac{a^2+1}{4-x}$ funksiyalar berilgan:

a) $f(x)$ funksiya $(-\infty; 3]$ da kamayishini isbotlang;

b) $g(x)$ funksiya $(-\infty; 3]$ da o'sishini isbotlang;

d) a ning $f(2) = g(2)$ bo'ladigan barcha qiymatlarini toping;

e) $x^2 - 6x + 9 = \frac{2}{4-x}$ tenglamani $(-\infty; 3]$ oraliqda yeching.

7.152. Agar $f(x)$ funksiya X to'plamda o'suvchi (kamayuvchi), $g(x)$ funksiya esa X to'plamda kamayuvchi (o'suvchi) bo'lsa, $f(x) = g(x)$ tenglama X to'plamda ko'pi bilan bitta ildizga ega bo'lishini isbotlang.

7.153. Funksiyalarning nollarini toping:

a) $f(x) = 3x^2 - 4$;

b) $f(x) = 2x^2 - 5x + 6$;

d) $f(x) = \sqrt{x-1} + \sqrt{2-x}$;

e) $f(x) = \frac{x}{x-1} - \frac{2x}{x+1}$;

f) $f(x) = |x - 1| \cdot \left| \frac{x+1}{x^2-1} \right|;$

g) $f(x) = x^3 + 8x^2 - x;$

h) $f(x) = \frac{x-1}{x^2-7x+12};$

i) $f(x) = \frac{x^2-4}{x^2-11x+30}.$

Funksiyalarning o'sish va kamayish oraliqlarini toping (7.154–7.157):

7.154. $y = 1 - 2x.$

7.155. $y = 3 - 2x - x^2.$

7.156. $y = x^3.$

7.157. $y = \frac{1}{x+1}.$

Funksiyalarning eng katta qiymatini va argumentning unga mos qiymatlarini ko'rsating (7.158–7.166):

7.158. $y = 5 - |x + 8|.$

7.159. $y = 2 - \sqrt{x - 2}.$

7.160. $y = x^2 - 2x + 3, x \in [1; 5].$

7.161. $y = -x^2 - 4x + 1, x \in [-3; 0].$

7.162. $y = \frac{2}{5+|3x-2|}.$

7.163. $y = \frac{2}{x^2-2x+2}.$

7.164. $y = \frac{2x}{x^2+1}.$

7.165. $y = \frac{4x}{x^2+4}.$

7.166. $y = \frac{x}{4x^2+9}.$

Funksiyaning eng kichik qiymatini va argumentning funksiya bu qiymatga erishadigan qiymatlarini toping (7.167–7.174):

7.167. $y = \sqrt{4x^2 - 12x + 9} - 2.$

7.168. $y = 3 + \sqrt{x^2 - 3x + 2}.$

7.169. $y = x^2 + 6x + 11, x \in [-4; 2].$

7.170. $y = -x^2 + 2x + 2, x \in [-1; 2].$

7.171. $y = -\frac{3}{|x+1|+1}.$

7.172. $y = -\frac{2}{x^2+1}.$

7.173. $y = -\frac{x}{2x^3+3}.$

7.174. $y = \frac{x^2+4x+4}{x^2+4x+5}.$

7.175. $f(x)$ juft funksiya va $x \geq 0$ da $f(x) = \sqrt{x}$ bo'lsa, $f(x)$ funksiyaning grafigini yasang.

7.176. $f(x)$ juft funksiya va $x \leq 0$ da $f(x) = x^2 - 3x$ bo'lsa, $f(x)$ funksiyaning grafigini yasang.

- 7.177. a) $f(x)$ toq funksiya va $x \leq 0$ da $f(x) = x^2$ bo'lsa, $f(x)$ funksiyaning grafigini yasang;
 b) $f(x)$ toq funksiya va $x \leq 0$ da $f(x) = x^2 - 2x$ bo'lsa, $f(x)$ funksiyaning grafigini yasang.

Funksiyalarning grafigini yasang (7.178–7.191):

7.178. $y = \frac{x+2}{|x+2|} (x^2 + 4x + 3)$.

7.179. $y = ||x| - 2| - 1|$.

7.180. $y = |2 - |1 - |x|||$.

7.181. $y = |x^2 - 5|x| + 6|$.

7.182. $y = \sqrt{4x^2 - 4x^2|x| + x^4}$.

7.183. $y = ||1 - x^2| - 3|$.

7.184. $y = ||x^2 - 2x| - 3|$.

7.185. $y = 2 - \sqrt{|x - 3|}$.

7.186. $y = 2 - \sqrt{3 - |x|}$.

7.187. $y = |2 - \sqrt{|x - 3|}|$.

7.188. $y = |2 - \sqrt{3 - |x|}|$.

7.189. $y = \frac{|x|}{x-1}$.

7.190. $y = \frac{|x|}{|x|-1}$.

7.191. $y = \left| \frac{x}{x-1} \right|$.

- 7.192. 66- rasmda $y = ax^2$ parabola va Ox o'qiga parallel (l) to'g'ri chiziq (parabola direktrissi), $F\left(0; \frac{p}{2}\right)$ – parabola fokusi tasvirlangan, $p = \frac{1}{2|a|}$:

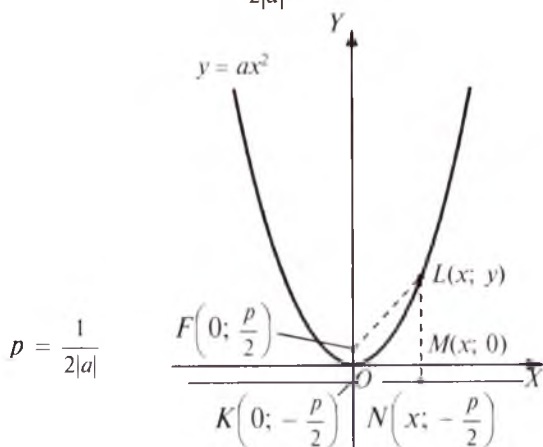

66- rasm.

- a) paraboladagi ixtiyoriy $L(x; y)$ nuqta uchun $FL = LN$ bo'lishini isbot qiling;
- b) parabolani $y = x$ bissektrisaga nisbatan geometrik almashtiring, hosil bo'ladigan $x = \varphi(y)$, $y \geq 0$ bog'lanishning aniqlanish va o'zgarish sohaslarini toping. Kvadratik funksiya chekli ayirmalarining xossasi qaysi o'zgaruvchiga nisbatan saqlanadi?
- d) bog'lanishni $y = f(x)$ ko'rinishga keltiring.

3. Davriy funksiya. Tabiatda va amaliyotda ma'lum bir T vaqt o'tishi bilan qaytadan takrorlanadigan jarayonlar uchray turadi. Masalan, har $T = 12$ soatda soat mili bir marta to'liq aylanadi va oldin biror t vaqt momentida qanday o'rinda turgan bo'lsa, keyingi $t + T$, $t + 2T$, umuman, $t + kT$, $k \in \mathbb{Z}$ vaqt momentlarida yana shu o'ringa qaytadi. Quyosh bilan Yer orasidagi masofa $T = 1$ yil davomida o'zgaradi, ikkinchi yilda o'zgarish shu ko'rinishda takrorlanadi.

Umuman, shunday T soni mavjud bo'lsaki, $y = f(x)$ funksiyaning $D(f)$ aniqlanish sohasidan olingan har qanday x uchun $x + T$, $x - T$ sonlari ham $D(f)$ ga tegishli bo'lsa va $f(x) = f(x + T) = f(x - T)$ tengliklar bajarilsa, f funksiya *davriy funksiya*, T son shu funksiyaning *davri*, eng kichik musbat davr esa funksiyaning *asosiy davri* deyiladi.

1-teorema. *Agar T soni f funksiyaning davri bo'lsa, $-T$ ham uning davri bo'ladi. Agar T_1 va T_2 lar f funksiyaning davrlari bo'lsa, $T_1 + T_2$ ham shu funksiyaning davri bo'ladi.*

Isbot. $-T$ soni f funksiyaning davri ekani ta'rif bo'yicha $f(x) = f(x - T) = f(x + T)$ tenglikning bajarilayotganligidan kelib chiqadi. $T_1 + T_2$ ning davr ekani shu kabi isbotlanadi: $f(t + (T_1 + T_2)) = f(t + T_1 + T_2) = f(t + T_1) = f(t)$, $f(t - (T_1 + T_2)) = f(t - T_1 - T_2) = f(t - T_1) = f(t)$.

Natija. *Agar T son f funksiyaning davri bo'lsa, kT son ham uning davri bo'ladi, bunda k — butun son.*

Isbot. Matematik induksiya metodidan foydalanamiz. $k=1$ da teorema to'g'ri: $kT = T$, T esa shart bo'yicha davr. Agar kT funksiyaning davri bo'lsa, 1- teoreмага asosan, $kT + T = (k+1)T$ ham davr. U holda induksiya bo'yicha barcha k butun sonlarda kT lar funksiyaning davri bo'ladi.

2- teorema. *Agar T soni f funksiyaning asosiy davri bo'lsa, funksiyaning qolgan barcha davrlari T ga bo'linadi.*

Isbot. Isbotni musbat davrlar uchun ko'rsatish yetarli. T soni funksiyaning asosiy davri, T_1 esa uning ixtiyoriy musbat davri bo'lsin. T_1 ning T ga bo'linishini ko'rsatamiz. Aksincha, T_1 soni T ga bo'linmaydi, deb faraz qilaylik. U holda $T_1 = kT + m$ ga ega bo'lamiz, bunda $k \in \mathbb{N}$, $0 < m < T$. Lekin T va T_1 sonlari davr bo'lgani uchun $m = T_1 - kT$ soni ham davr bo'ladi (1- teoreмага muvofiq). $0 < m < T$ ekani va m soni davr bo'lganidan T soni asosiy davr bo'la olmaydi. Zidlik hosil bo'ldi. Demak, faraz noto'g'ri. Bundan ko'rinadiki T_1 son T ga bo'linadi. Shu bilan teorema isbot bo'ldi.

Agar f davriy funksiya grafigining biror $[a; a + T]$ oraliqdagi qismi yasalgan bo'lsa, bu qismni Ox o'qi bo'yicha ketma-ket parallel ko'chirishlar bilan qolgan qismlarni yasash mumkin.

Misol. $y = \{x\}$ funksiyaning davriyligi va asosiy davri $T = 1$ bo'lishini isbot qilamiz, bunda $\{x\} = x - [x]$.

Isbot. x ga har qanday T butun son qo'shilsa ham x ning kasr qismi o'zgarmaydi: $\{x + T\} = \{x\}$. Demak, $\{x\}$ funksiya davriy funksiya va har qanday butun son uning davri. $T = 1$ soni shu funksiyaning asosiy davri ekanini isbot qilamiz. Buning uchun $T_1 \in (0; 1)$ soni $\{x\}$ ning davri bo'la olmasligini ko'rsatishimiz kerak. Aksincha, u ham davr bo'lishi mumkin, deylik. U holda $\{x + T_1\} = \{x\}$ bo'ladi. Xususan, $x = 0$ da $\{0 + T_1\} = \{0\} = 0$ ga ega bo'lamiz. Ikkinchi tomondan, $\{0 + T_1\} = \{T_1\} = T_1$. Keyingi ikki tenglikdan $T_1 = 0$ ekani kelib chiqadi. Bu esa $T_1 \in (0; 1)$ bo'lishiga zid. Demak, T soni $\{x\}$ funksiyaning davri, uning asosiy davri 1 sonidan iborat.



Mashqlar

7.193. Funktsiyalarni davriylikka tekshiring:

- a) $y = x$; b) $y = \{x\} + 1$; d) $y = 5$;
 e) $y = x^2$; f) $y = [x] - 1$; g) $y = 5 + x$;
 h) $y = \{x\}$; i) $y = x^2 + \{x\}$; j) $y = \{5 + x\}$;
 k) $y = [x]$; l) $y = [x] + x$; m) $y = [5 + x]$.

7.194. Davrlari T ga teng ikki funktsiyaning yig'indisi, ko'paytmasi va bo'linmasining ham davri T ga teng bo'lishini isbot qiling.

7.195. Agar $\frac{5}{3}$ va $\frac{2}{7}$ sonlari f funktsiyaning davrlari bo'lsa, $\frac{17}{21}$ soni ham uning davri bo'lishini isbot qiling.

7.196. Agar f va g funktsiyalar bir xil T davrga ega bo'lsalar, u holda $F(x) = f\left(\frac{x}{k}\right) + g\left(\frac{x}{l}\right)$ funktsiyaning davri mT bo'lishini isbot qiling, bunda m soni k va l ning eng kichik umumiy bo'linuvchisi.

7.197. Funktsiyalarning davrini toping:

- a) $y = 2\left\{\frac{x}{2}\right\} + 4\left\{\frac{x}{3}\right\}$; b) $y = \{2x\} + 7\{3x\}$;
 d) $y = \sqrt{1 + \{5x\}}$; e) $y = \frac{2\{6x\} - \{4x\}}{3\{6x\} + \{4x\}}$;
 f) $y = \{x\} + 8\{5,1x\}$; g) $y = \sqrt{\{6x\} + \{4x\} - 1}$;
 h) $y = \{3x - 0,2\} + \{2x + 0,3\}$;
 i) $y = \sqrt{\{2,8x\} - \{13x + 0,4\} + 5}$.

7.198. Har qanday ratsional son ushbu

$$f(x) = \begin{cases} 1, & x \in \mathcal{Q}, \\ 0, & x - \text{irrational son} \end{cases}$$

Dirixle funktsiyasining davri bo'lishini, lekin uning eng kichik musbat davri yo'qligini isbotlang.

199. Quyidagi funksiyalarning davriy emasligini isbot qiling:

a) $y = \sqrt{2|x|}$; b) $\{x^2\}$; d) $\{x\} + \{x\sqrt{3}\}$.

200. $f(x) = \begin{cases} -x, & \text{agar } 0 \leq x \leq 1, \\ \frac{1}{2}, & \text{agar } 1 \leq x \leq 2 \end{cases}$ funksiya berilgan. Shu

funksiya yordamida davriy funksiya tuzing va grafigini yasang.

4. Teskari funksiya. Agar $b=f(a)$ tenglikni qanoatlantiruvchi a ; b) qiymatlar jufti $a = \varphi(b)$ tenglikni ham qanoatlantirsa, ksincha $a = \varphi(b)$ ni qanoatlantiruvchi shu juft $b = f(a)$ ni ham qanoatlantirsa, $y = f(x)$ va $y = \varphi(x)$ funksiyalar *o'zaro teskari funksiyalar* deyiladi. Bu ikki funksiyadan ixtiyoriy birini *to'g'ri funksiya*, ikkinchisini esa birinchisiga nisbatan *teskari funksiya* deb atash mumkin. f funksiyaga teskari funksiya f^{-1} orqali belgilanadi: $f^{-1}(f(x)) = x$ va $f(f^{-1}(y)) = y$.

To'g'ri funksiya $y = f(x)$ bo'lsin. Uni x ga nisbatan yechib, $x = \varphi(y)$ ko'rinishga keltiramiz. $y = f(x)$ va $x = \varphi(y)$ — teng kuchli munosabatlar *bitta grafik* bilan tasvirlanadi (67- a rasm). Odatga ko'ra, funksiyani y orqali, argumentni x orqali belgilasak, $x = \varphi(y)$ bog'lanishda x va y larni almashtirib, ta'rifda ko'rsatilganidek, $y = \varphi(x)$ yozuvni olamiz. Bu holda f grafigida yotgan har bir $M(x; y)$ nuqta $y = x$ to'g'ri chiziqqa nisbatan o'ziga simmetrik

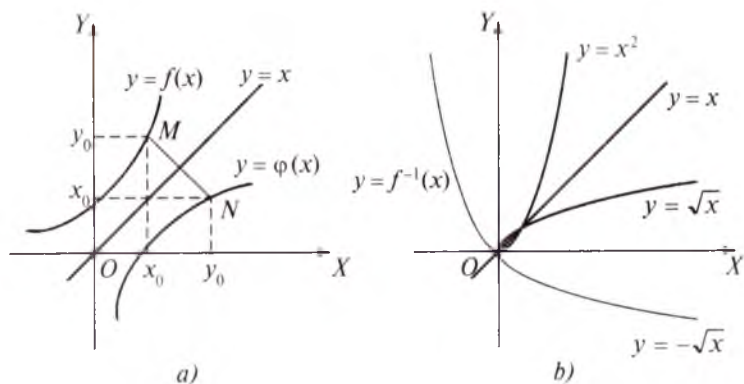

67- rasm.

holatda φ grafigida yotgan $N(y; x)$ nuqtaga o'tadi. Umuman, o'zaro teskari $f(x)$ va $\varphi(x)$ funksiyalar grafiglari $y = x$ bissektorisiga nisbatan simmetrik joylashadi. Lekin har qanday funksiya teskari funksiyaga ega bo'lavermaydi. Masalan, $y = x^2$ funksiya bo'yicha funksional bog'lanish bo'lmagan (har bir $y > 0$ qiymatga x ning ikki qiymati mos keladigan) $x = \pm\sqrt{y}$ munosabatga ega bo'lamiz. Lekin $y = x^2$, $0 \leq x < +\infty$ va $x = +\sqrt{y}$ yoki $y = x^2$, $-\infty < x \leq 0$ va $x = -\sqrt{y}$ lar o'zaro teskari bog'lanishlardir. $x = \sqrt{y}$ ni (harflarni almashtirib) $y = \sqrt{x}$ ko'rinishda yozamiz.

Ularning grafiglari 67- b rasmda tasvirlangan.

Agar X to'plamga qarashli $x_1 \neq x_2$ qiymatlarda funksiyaning mos qiymatlari $f(x_1) \neq f(x_2)$ bo'lsa, f funksiya X to'plamda *teskarilanuvchi funksiya* deyiladi.

Agar $f(x)$ funksiya X to'plamda *monoton* bo'lsa, u holda $y = f(x)$ funksiya teskarilanuvchi funksiya bo'ladi. Haqiqatan, f funksiya X da o'suvchi bo'lsin. U holda $x_1 < x_2$ larda $f(x_1) < f(x_2)$, ya'ni $f(x_1) \neq f(x_2)$ bo'ladi. Bunday hol f funksiya X to'plamda kamayuvchi bo'lganda ham o'rinli. f funksiyaning monotonligidan unga teskari f^{-1} funksiyaning mavjudligi kelib chiqadi. Agar f funksiya $[a; b]$ oraliqda o'ssa (yoki kamaysa) va uzluksiz bo'lsa, u $[f(a); f(b)]$ oraliqda (kamayuvchi bo'lganda $[f(b); f(a)]$ oraliqda) f^{-1} teskari funksiyaga ega bo'ladi.



Mashqlar

7.201. 67- d rasmda f funksiya grafigi tasvirlangan. Shu funksiya $(-\infty; +\infty)$ intervalda teskari funksiyaga ega bo'la oladimi? Qanday oraliqlarda teskari funksiyaga ega va nima uchun? Teskari funksiyalar grafiglarining eskizlarini chizing.

7.202. Funksiyaga teskari funksiyani toping:

a) $f(x) = 2x + 3$;

b) $f(x) = \frac{2x-1}{x+2}$;

d) $f(x) = x^2, x \in [0; +\infty)$;

e) $f(x) = x^2, x \in (-\infty; 0)$;

f) $f(x) = -x^2, x \in (-\infty; 0]$;

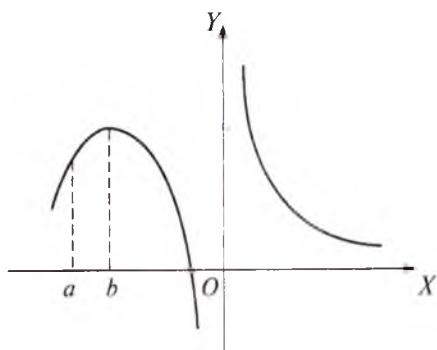

67-d rasm.

$$g) f(x) = \begin{cases} x, & \text{agar } x \in [0; 1), \\ 3 - x, & \text{agar } x \in [1; 2). \end{cases}$$

7.203. Funksiya teskarilanuvchimi:

$$a) f(x) = 3x^2 + 1; \quad b) f(x) = 3x + 4;$$

$$d) f(x) = 4x - 5; \quad e) f(x) = \frac{3x+1}{4x-2};$$

$$f) f(x) = \frac{7x-4}{3x+5}; \quad g) f(x) = \frac{dx+b}{cx+d};$$

$$h) f(x) = \begin{cases} x^2, & \text{agar } x \in [0; 1), \\ x - 1, & \text{agar } x \in [1; 2); \end{cases}$$

$$i) f(x) = \begin{cases} 3x+1, & \text{agar } x \in [0; 1), \\ -3x+1, & \text{agar } x \in [1; 2); \end{cases}$$

$$j) f(x) = \begin{cases} x^3, & \text{agar } x \leq 0 \text{ bo'lsa,} \\ x, & \text{agar } x > 0 \text{ bo'lsa;} \end{cases}$$

$$k) f(x) = \frac{3x^2}{1-3x} ?$$

5. Jadval bilan berilgan funksiya ifodasini tuzish.

1) $y = ax + b$, $a \neq 0$ chiziqli funksiyaning bir xil $h = x_i - x_{i-1}$, qadam bilan tuzilgan jadvali berilgan bo'lsin:

i	x_i	y_i	$\Delta y_i = y_{i+1} - y_i$
1	x_1	$y_1 = ax_1 + b$	$\Delta y_1 = a(x_2 - x_1) = ah$
2	x_2	$y_2 = ax_2 + b$	$\Delta y_2 = \dots = ah$
3	x_3	$y_3 = ax_3 + b$	$\Delta y_3 = \dots = ah$
...

Δy qiymatlar funksiyaning 1- tartibli *chekli ayirmalari* (1- §, 2- band, 3- misol). $y = ax + b$ chiziqli funksiyaning Δy chekli ayirmalari *o'zgarmas* va ah songa teng. Bu xususiyatdan funksiya tenglamasini tuzishda foydalanamiz.

1- misol. To'rt $(x_i; y_i)$ nuqtali (juftli) jadval berilgan:

x	1	2	3	4
y	14	14.6	15.2	15.8

$y = f(x)$ funksiya tenglamasini tuzing.

Yechish. Jadvalni Δy chekli ayirmalargacha davom ettiraylik:

x	1	2	3	4
y	14	14,6	15,2	15,8
Δy	0,6	0,6	0,6	$= ah$

Jadval qadami $h = 1$ da Δy chekli ayirmalar bir xil, $\Delta y = 0,6$. Demak, jadval $y = ax + b$ chiziqli funksiyani ifodalaydi. a va b koeffitsiyentlarni aniqlaymiz.

1- usul. Noma'lumlar soni ikkita. Jadvaldan ixtiyoriy ikki juftni, masalan, $(1; 14)$, $(3; 15,2)$ ni $ax + b = y$ ga qo'yib sistemani

tuzamiz:
$$\begin{cases} a \cdot 1 + b = 14, \\ a \cdot 3 + b = 15,2. \end{cases}$$

Bu sistemadan $a = 0,6$ va $b = 13,4$ sonlarini topamiz. Demak, $y = 0,6x + 13,4$ tenglama $y = f(x)$ funksiya tenglamasidir.

2- usul. $\Delta y = ah$ bo'yicha $0,6 = a \cdot 1$, bundan $a = 0,6$. Bu qiymatni va ixtiyoriy juftni, masalan, $(1; 14)$ ni $ax + b = y$ ga qo'yib. natijadan b ni topamiz: $0,6 \cdot 1 + b = 14$, $b = 13,4$. Tenglama: $y = 0,6x + 13,4$.

Topilgan munosabatning aniqligini bilish uchun unga x ning jadval qiymatlaridan qo'yish, topilgan natija bilan y ning jadval qiymati orasidagi ε chetlanishni (xatoni) hisoblash kerak. Masalan, $\varepsilon_1 = (0,6 \cdot 1 + 13,4) - 14 = 14 - 14 = 0$. Formula aniq natijani bergan.

2- misol. Asosi $a = 60$ mm, balandligi $h = 16$ mm bo'lgan o'tkir burchakli uchburchak ichiga bir necha to'g'ri to'rtburchak shunday chizilganki, ularning ikki uchi uchburchakning asosida, qolgan ikki uchi yon tomonlarida yotadi. To'rtburchak x (mm) balandligining o'zgarishiga bog'liq holda asosi y (mm) ning o'zgarishi kuzatilgan va natijalar $h = 5$ mm qadamli jadvalda berilgan: $h = 5$, $\Delta y = 54 - 60 = 48 - 54 = \dots = -6$.

x	0	5	10	15
y	60	54	48	42
Δy	-6	-6	-6	

$y = f(x)$ bog'lanishning tenglamasini tuzamiz va undan foydalanib, $x = 6, 12, 14$ ga mos y ning qiymatini topamiz. Chekli ayirmalar 1- misolda musbat edi. Qanday sababga ko'ra ushbu misolda ular manfiy bo'lmoqda?

Yechish. $\Delta y = -6 = \text{const}$. Bog'lanishni $y = ax + b$ ko'rinishda izlaymiz. $\Delta y = ah$ bo'yicha $-6 = a \cdot 5$, $a = -6/5$. Bu qiymatni va ixtiyoriy tartibda $(0; 60)$ juftni $ax + b = y$ ga qo'yamiz. Undan $b = 60$ topiladi. Izlanayotgan bog'lanish: $y = -\frac{6}{5}x + 60$. Unga ketma-ket $x = 6, 12, 14$ lar qo'yilsa, $y = 52,8; 45,6; 43,2$ topiladi. 1- misolda qaralgan funksiya o'suvchi, shunga ko'ra uning chekli ayirmalari musbat. Ushbu misolda esa kamayuvchi funksiya qaralmoqda. Uning chekli ayirmalari manfiy bo'ladi.

$h = x_i - x_{i-1}$ const qadam bilan $y = ax^2 + bx + c$ kvadrat funksiyaning jadvalini tuzaylik (lot. *constans* yoki *constantis* – konstanta, doimiy kattalik, o'zgarmas):

x_1	$y_1 = ax_1^2 + bx_1 + c$	$\Delta y_1 = y_2 - y_1 = (2ax_1 + b)h + ah^2$
$x_2 = x_1 + h$	$y_2 = ax_2^2 + bx_2 + c$	$\Delta y_2 = y_3 - y_2 = (2ax_1 + b)h + 3ah^2$
$x_3 = x_1 + 2h$	$y_3 = ax_3^2 + bx_3 + c$	$\Delta y_3 = y_4 - y_3 = (2ax_1 + b)h + 5ah^2$
$x_4 = x_1 + 3h$	$y_4 = ax_4^2 + bx_4 + c$	

Chekli ayirmalar bir xil emas. Ular ayirmasi $2ah^2$ ga teng bo'lgan arifmetik progressiya tashkil etmoqda.

Ikkinchi ayirmalarni qaraymiz: $\Delta^2 y_1 = \Delta y_2 - \Delta y_1 = 2ah^2$, $\Delta^2 y_2 = \Delta y_3 - \Delta y_2 = 2ah^2$ va hokazo. Shunday qilib, agar $y = ax^2 + bx + c$ kvadrat funksiya jadvali o'zgarmas $h = x_i - x_{i-1}$ qadam bilan tuzilgan bo'lsa, ikkinchi ayirmalar o'zgarmas bo'lib, $2ah^2$ ga teng bo'ladi va, aksincha, o'zgarmas qadamli jadvalda ikkinchi tartibli ayirmalar doimiy bo'lsa, jadval kvadrat uchhad orqali ifodalanishi mumkin.

3- m i s o l. Tebranish T (s) tebranish davrining h (m) uzunligiga bog'liqligi kuzatilgan va quyidagi jadval tuzilgan (qadam $t = 1$ sekund):

T	0	1	2	3	4
h	0	0,236	0,944	2,124	3,776
Δh	0,236	0,708	1,180	1,652	
$\Delta^2 h$	0,472	0,472	0,472		

$h = f(T)$ funksiya formulasini tuzing.

Yechish. Δ^2 ayirmalar o'zgarmas. $T = 0$ da $h = 0$ bo'lgan. Demak, funksiya grafigi koordinatalar boshidan o'tuvchi parabola. Uning tenglamasini $h = aT^2 + bT = T(aT + b)$ ko'rinishda izlaymiz. Unda a va b koeffitsiyentlar noma'lum. Bundagi a ni $\Delta^2 y = 2ah^2$ bo'yicha topamiz: $0,472 = 2ah^2$, $a = 0,236$. Endi b ni topish uchun jadvaldan ixtiyoriy ($T; h$) juftni, masalan, $(0; 0)$ ni tenglamaga qo'yamiz: $a \cdot 0 + b = 0$, bundan $b = 0$.

Demak, izlanayotgan tenglama $h = 0,236 T^2$.

4- misol. Ishlab chiqarilgan mahsulotning x miqdoriga uning y tannarxining bog'liqligi jadvali tuzilgan, qadami doimiy emas:

x	0,5	1	2	4	10	20
y	8,4	4,6	2,5	1,6	0,9	0,8

$y = f(x)$ bog'lanishning formulasini tuzamiz.

Yechish. Jadval qadami $h \neq \text{const}$. Bu holda chekli ayirmalardan foydalana olmaymiz. Bog'lanishning grafigini nuqtalar bo'yicha chizamiz (68- rasm). Chizma giperbolaning bir tarmog'iga o'xshaydi. Formulani $y = a + \frac{b}{x}$ ko'rinishida izlaymiz, unda a va b noma'lumlar qatnashmoqda. Jadvaldan ixtiyoriy tartibda ikkita, masalan, $(0,5; 8,4)$ va $(4; 1,6)$ juftlarni

formula ifodasiga qo'yamiz:
$$\begin{cases} 8,4 = a + \frac{b}{0,5}, \\ 1,6 = a + \frac{b}{4}. \end{cases}$$
 bundan $a \approx 0,62$, $b \approx$

$\approx 3,89$ tenglama $y \approx 0,62 + \frac{3,89}{x}$ bo'ladi. Formula bog'lanishni taqribiy ifodalaydi. Masalan, $x = 4$ da formula bo'yicha $y = 1,59$ ni

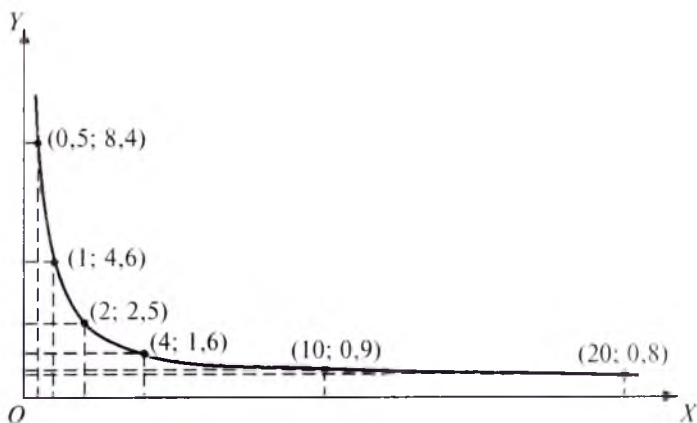

68- rasm.

topamiz, jadvalda esa $y = 1,6$. Formula xatosi $\varepsilon = 1,59 - 1,6 = -0,01$. Aniqlikni oshirish masalalari bilan keyinroq shug'ullanamiz



Mashqlar

- 7.204.** Podadan tavakkaliga 5 ta qo'y ajratilib, bo'yin yelkasidan dumg'azasigacha o'lchangan (l , sm) va tarozida tortilgan (P , kg). Natija quyidagicha bo'lgan:

l	51	52	53	54	55
P	37	39	41	43	45

Shu zotdagi qo'ylarning P og'irligini l uzunliklari bo'yicha aniqlash uchun formula tuzing. Formuladan foydalanib, $l = 52,3; 54,5$ (sm) da P (kg) ni taqriban aniqlang.

- 7.205.** Usta o'z ishini $x\%$ ga bajarsa, ishxona o'z ishini $y\%$ ga bajargan bo'ladi (jadvalga qarang). Bog'lanish formulasini tuzing.

x	7	14	21	28	35
y	2	4	6	8	10

- 7.206.** Ko'prik arki parabola yoyi shaklida bo'lib, arkning A uchi yoyning o'rtasida joylashgan (69- rasm). Ark vertikal ustunlarga ega, ular arkni tortib turuvchi vatar bo'yicha har 10 m dan so'ng joylashtirilgan. Arkning balandligi 8 m. Ustunlarning uzunligini toping.

- 7.207.** I (A) tok kuchining R (Om) qarshilikka bog'liqligi kuzatilgan (jadvalga qarang), kuchlanish doimiy. $I = f(R)$ bog'lanishning tenglamasini tuzing.

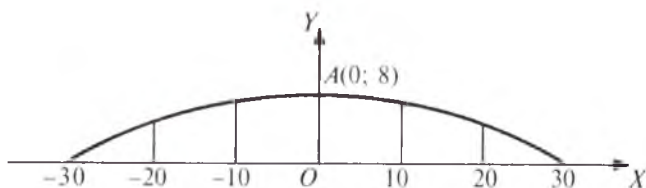

69- rasm.

R	20	40	60	80
l	4,99	2,49	1,67	1,25

- 7.208.** 45- mashqda agar $A(0; 20000)$ va $B(18; 42000)$ bo'lsa, $y = kx + l$ (1) xarajat va $y = ax$ (2) daromad funksiyalari ifodalarini tuzing. Agar korxonada 2592 ming so'mlik buyum ishlab chiqargan va uni sotgan bo'lsa, qancha sof foyda olgan bo'ladi?

Takrorlashga doir mashqlar

- 7.209.** Funksiyaning aniqlanish sohasi va qiymatlar sohasini toping:

a) $y = \sqrt{x-1}$; b) $y = \frac{x^2-4}{x^2-9}$; d) $y = \frac{1}{\sqrt{x^2-x}}$;

e) $y = \sqrt[3]{1+x}$; f) $y = \frac{\sqrt{x(x+1)}}{x+4}$; g) $y = \sqrt{x^2-1}$.

- 7.210.** $y=x$ va $y = \frac{x^2}{x}$ funksiyalarning aniqlanish sohalari ustma-ust tushadimi? Agar ustma-ust tushmasa, aniqlanish sohalarining umumiy qismini toping.

- 7.211.** Jumlaning ma'nosini tushuntiring:

- a) funksiya yuqoridan (quyidan) chegaralangan;
- b) funksiya yuqoridan (quyidan) chegaralanmagan;
- d) funksiya chegaralangan;
- e) funksiya chegaralangan emas.

- 7.212.** Isbotlang:

a) $y = \frac{1}{x}$ funksiya yuqoridan chegaralangan emas;

b) $y = \frac{1}{x}$ funksiya quyidan chegaralangan emas;

d) $y = x^2$ funksiya yuqoridan chegaralangan emas;

e) $y = x^2$ funksiya chegaralangan emas.

7.213. Shunday funksiya quringki, bu funksiya juft ham bo'lmasin, toq ham bo'lmasin.

7.214. Har qanday funksiyani ham juft va toq funksiyalarning yig'indisi shaklida yozish mumkinmi? $y = \sqrt{x}$ funksiyani misol sifatida qarang.

7.215. Funksiyaning monotonligini isbotlang:

a) $y = \sqrt{x}$; b) $y = x^3$.

7.216. Funksiya monoton funksiya bo'la oladimi (agar bo'la olmasa, monotonlik oraliqlarini toping):

a) $y = \frac{1}{|x|}$; b) $y = x - [x]$;

d) $y = \sqrt[3]{x^2}$; e) $y = \sqrt{5 - 4x}$;

f) $y = \frac{x+1}{x-2}$; g) $y = |x^2 - 3x + 2|$;

h) $y = \sqrt{1 - x^2}$?

7.217. Ikkita monoton funksiyaning yig'indisi monoton bo'lmashligi mumkinmi?

7.218. Monoton o'suvchi funksiyalarning ko'paytmasi hamma vaqt ham monoton o'suvchi funksiya bo'ladimi?

7.219. $[0; 2]$ oraliqda berilgan funksiyani ikkita monoton o'suvchi funksiyalarning ayirmasi shaklida tasvirlang:

$$y = \begin{cases} x^2, & \text{agar } 0 \leq x < 1 \text{ bo'lsa,} \\ 5, & \text{agar } x = 1 \text{ bo'lsa,} \\ x + 3, & \text{agar } 1 < x \leq 2 \text{ bo'lsa.} \end{cases}$$

7.220. Monoton bo'lmagan funksiyani ikkita monoton funksiyaning ayirmasi shaklida tasvirlash mumkinmi?

7.221. $y = \{x\}$ funksiya davriy funksiya ekanligini isbotlang. Uning davrini toping va grafigini yasang.

7.222. Davri $T = 2$ bo'lgan $f(x)$ davriy funksiya $[-1; 1]$ oraliqda

$$y = \begin{cases} x + 1, & \text{agar } -1 \leq x \leq 0 \text{ bo'lsa,} \\ x, & \text{agar } 0 < x \leq 1 \text{ bo'lsa} \end{cases} \text{ funksiya bilan ustma-ust}$$

tushadi. $f(x)$ funksiya grafigini yasang.

7.223. Davri $T = 3$ bo'lgan f funksiya $(0; 3]$ oraliqda $y = 2 - x$ funksiya bilan ustma-ust tushadi. $f(x)$ funksiya grafigini yasang.

7.224. Funksiyalarning grafiglarini ayni bir koordinatalar sistemasida yasang:

a) $y = x$; $y = x^2$, $y = x^3$, $y = x^4$, $y = x^5$;

b) $y = x$, $y = \sqrt{x}$, $y = \sqrt[3]{x}$, $y = \sqrt[4]{x}$, $y = \sqrt[5]{x}$.

7.225. Quyidagi funksiyalarning grafiglarini yasang:

a) $y = \sqrt{\frac{1}{x}}$; b) $y = \left[\frac{1}{x}\right]$; d) $y = \lceil x^2 \rceil$;

e) $y = \begin{cases} x^3, & \text{agar } x \geq -2 \text{ bo'lsa,} \\ \frac{1}{x}, & \text{agar } -2 < x < -1 \text{ bo'lsa,} \\ x^2, & \text{agar } -1 \leq x < 2 \text{ bo'lsa,} \\ \sqrt{x}, & \text{agar } x \geq 2 \text{ bo'lsa.} \end{cases}$

f) $y = x^2 + 5|x - 1| + 1$; g) $y = |-3x + 1| - |2x - 3|$;

h) $y = |x^2 - 3x + 1| - |2x - 3|$;

i) $y = (x + 1)(|x| - 2)$;

j) $y = \frac{2x+1}{2-x}$;

k) $y = 1 - \frac{1}{|x|}$; l) $y = \frac{2x-6}{|3-x|}$; m) $y = \frac{|x-1|}{1-x^2}$.

7.226. Funksiyaga teskari funksiyani toping va teskari funksiyaning grafigini yasang:

a) $y = 3x - 2$; b) $y = -(x + 2)^2 - 2$, $x \in (-\infty; -1)$;

d) $y = \frac{x+1}{x-1}$, $y \in (1; +\infty)$; e) $y = \sqrt{x^2 - 4}$, $x \in [2; +\infty)$.

7.227. Agar $A(1; 2)$ nuqta $y = x^2 + px + q$ parabolaning uchi bo'lsa, p va q ni toping.

7.228. Agar $M(-1; -7)$ nuqta koordinatalar o'qini $N(0; -4)$ nuqtada kesuvchi $y = ax^2 + bx + c$ parabolaning uchi bo'lsa, a , b , c larni toping.

- 7.229.** Agar $y = ax^2 + bx + c$ funksiyaning grafigi $A(1; 4)$, $B(-1; 10)$, $C(2; 7)$ nuqtalar orqali o'tsa, $y = ax^2 + bx + c$ funksiyani toping.
- 7.230.** Uchi $A(1; 1)$ nuqta bo'lgan $y = ax^2 + bx + c$ parabola $B(-1; 5)$ nuqta orqali o'tadi. Bu parabolaning absissasi 5 ga teng bo'lgan nuqtasining ordinatasini toping.
- 7.231.** $x = 2$ to'g'ri chiziq, $y = ax^2 - (a + 6)x + 9$ kvadrat uchhad grafigini yasang.
- 7.232.** $y = x^2 - 6x + a$ funksiyaning eng kichik qiymati 1 ga teng. Funksiya grafigini yasang.
- 7.233.** $y = -x^2 + 4x + a$ funksiyaning eng katta qiymati 2 ga teng. Funksiya grafigini yasang.
- 7.234.** $y = 2x^2 + (a + 2)x + a$ funksiyaning x_1 va x_2 nollari uchun $\frac{1}{x_1} + \frac{1}{x_2} = 3$ munosabat o'rinli bo'lsa, uning grafigini yasang.
- 7.235.** a ning qanday qiymatlarida $y = -x^2 + 4x + a$ funksiyaning qiymatlari to'plami $y = \sqrt{2x - a}$ funksiyaning aniqlanish sohasi bilan ustma-ust tushadi?
- 7.236.** b ning qanday qiymatlarida $y = 2bx^2 + 2x + 1$ va $y = 5x^2 + 2bx - 2$ funksiyalarning grafiglari bitta nuqtada kesishadi?
- 7.237.** $y = x^2 + 6x - 3$ va $y = (x + 3)^2 - 25$ funksiyalarning grafiglari $x = a$ to'g'ri chiziq bilan kesishgan. Kesishish nuqtalari orasidagi masofani toping.
- 7.238.** c ning qanday qiymatlarida $y = cx^2 - x + c$ va $y = cx + 1 - c$ funksiyalarning grafiglari umumiy nuqtaga ega bo'lmaydi?
- 7.239.** Funksiyaning grafigini yasang va uning yordamida funksiyaning nollari, ishorasi saqlanadigan oraliqlarini, funksiyaning eng katta va eng kichik qiymatlarini, qiymatlari sohasini ko'rsating:

$$a) y = \begin{cases} 3, & \text{agar } x \leq -4 \text{ bo'lsa,} \\ |x^2 - 4|x| + 3|, & \text{agar } -4 < x \leq 4 \text{ bo'lsa,} \\ 3 - (x - 4)^2, & \text{agar } x > 4 \text{ bo'lsa;} \end{cases}$$

$$b) y = \begin{cases} 8 - (x + 6)^2, & \text{agar } x < -6 \text{ bo'lsa,} \\ |x^2 - 6|x| + 8|, & \text{agar } -6 \leq x < 5 \text{ bo'lsa,} \\ 3, & \text{agar } x \geq 5 \text{ bo'lsa;} \end{cases}$$

$$d) y = \begin{cases} ||x| - 1| - 1|, & \text{agar } |x| < 2 \text{ bo'lsa,} \\ \sqrt{|x| - 2}, & \text{agar } |x| \geq 2 \text{ bo'lsa;} \end{cases}$$

$$e) y = \begin{cases} 2 - \sqrt{4 - |x|}, & \text{agar } |x| \leq 4 \text{ bo'lsa,} \\ \frac{8}{|x|}, & \text{agar } |x| > 4 \text{ bo'lsa.} \end{cases}$$

7.240. $f(x) = x^2 - 6x$ funksiya berilgan. Quyidagi funksiyalarning grafiklarini yasang:

$$a) y = f(x) - 2; \quad b) y = f(x - 2); \quad d) y = 2f(x);$$

$$e) y = f(2x); \quad f) y = -f(x); \quad g) y = f(-x);$$

$$h) y = f(|x|); \quad i) y = |f(x)|; \quad j) y = |f(|x|)|.$$

7.241. Funksiyaning eng katta qiymatini toping:

$$a) y = \frac{x}{1+x^2}; \quad b) y = \frac{x}{1+x+x^2}.$$

7.242. $y = \frac{x^2+3}{1+x}$ ($x > -1$) funksiyaning eng kichik qiymatini toping.

7.243. $f(x) = \sqrt{x}$, $g(t) = \frac{t^2}{t-1}$ bo'lsa, $f(g(t))$ ni toping.

7.244. $f(x) = \frac{\sqrt{x-1}}{x}$, $g(t) = \frac{2t^2-2t+1}{(t-1)^2}$ bo'lsa, $f(g(t))$ ni toping.

7.245. $f(x) = \frac{x^2}{\sqrt{x+1}}$, $g(t) = \frac{t^2-\sqrt{t}}{t}$ bo'lsa, $f(g(t))$ ni toping.

1- §. Ko'rsatkichli funksiya

1. Irratsional ko'rsatkichli daraja. $a > 0$, $a \neq 1$ soni va $x > 0$ irratsional son berilgan bo'lsin. r_n ratsional sonlar x ga kami bilan, s_m ratsional sonlar ortig'i bilan (o'nli) yaqinlashsin, $r_n < x < s_m$, $n, m \in \mathbb{N}$. U holda $a > 1$ da $a^{r_n} < x < a^{s_m}$ bo'ladi. Bu esa barcha a^{r_n} sonlarning A to'plami a^{s_m} sonlar B to'plamining chap tomonida yotishini va bu to'plamlarni hech bo'lmasa bitta son ajratishini bildiradi. Bu son irratsional ko'rsatkichli a^x darajaning qiymati sifatida qabul qilinadi.

$0 < a < 1$ holi ham shunday qaraladi. Faqat bunda A va B to'plamlarning rollari almashadi.

Irratsional ko'rsatkichli a^x darajaning xossalari ratsional ko'rsatkichli darajaning xossalariга o'xshash (a, b lar musbat, α va β lar haqiqiy sonlar):

$$1) (ab)^\alpha = a^\alpha b^\alpha; \quad 2) \left(\frac{a}{b}\right)^\alpha = \frac{a^\alpha}{b^\alpha}; \quad 3) a^\alpha a^\beta = a^{\alpha + \beta};$$

$$4) \frac{a^\alpha}{b^\beta} = a^{\alpha - \beta}; \quad 5) (a^\alpha)^\beta = a^{\alpha\beta}.$$

Darajalarni taqqoslashda ushbu ta'kiddan ham foydalaniladi:

Agar $a > 1$ va $m \in \mathbb{N}$ bo'lsa, $a^m > 1$ yoki $\sqrt[m]{a^m} = a > 1$, shu kabi $a > 1$ va ixtiyoriy $r > 0$ da $a^r > 1$ bo'ladi. Agar $a > 1$, $r < s$ bo'lsa, $a^r < a^s$ bo'ladi. Haqiqatan, $a^s = a^r \cdot a^{s-r} > a^r \cdot 1 = a^r$. Aksincha, $a > 1$ va $0 < a^r < a^s$ bo'lsa, $r < s$ bo'ladi (isbot qiling). Shuningdek, $0 < a < 1$ va $r < s$ bo'lgan holda $a^r > a^s$ bo'lishi ham shu kabi isbotlanadi.

Misol. $0,5^\alpha > 0,5^\beta$ bo'lsa, α kattami yoki β mi?

Yechish. $a = 0,5$, ya'ni $0 < a < 1$ bo'lgani uchun $\beta > \alpha$.



Mashqlar

8.1. Nolga teng bo'lmagan a va b sonlari uchun $(ab)^\alpha = a^\alpha b^\alpha$, $a \in R$ munosabatni isbot qiling.

8.2. Quyidagi sonlardan qaysi biri katta:

a) $2^{1.41}$ mi yoki $0,125^{-\frac{\sqrt{2}}{3}}$ mi; b) $3^{\sqrt{5}}$ mi yoki $3^{\sqrt[3]{9}}$ mi?

8.3. Sonlarni o'sib borish tartibida joylashtiring:

$$\pi^{\sqrt{3}}, (\sqrt{3})^\pi, \sqrt{\pi^3}.$$

8.4. $\left(\frac{3}{7}\right)^{2\sqrt{2}} - 1$ ayirmaning ishorasini aniqlang.

8.5. Agar: a) $\left(\frac{2}{3}\right)^\alpha = 2$ bo'lsa, α ning; b) $a + 4^{0.3\sqrt{2}} = 5$ bo'lsa, $a - 1$ ning ishorasini aniqlang.

8.6. $3^{\sqrt{3}} < 7$ tengsizlikni isbotlang.

2. Ko'rsatkichli funksiya va uning xossalari. $a > 0$, $a \neq 1$ bo'lsin.

$f(x) = a^x$ tenglik bilan aniqlangan funksiya a asosli *ko'rsatkichli funksiya* deyiladi. Bu funksiya barcha haqiqiy sonlar to'plamida aniqlangan, $D(f) = R$, chunki $a > 0$ bo'lganda a^x daraja barcha $x \in R$ uchun ma'noga ega. x ning istalgan haqiqiy qiymatida $a^x > 0$ bo'lgani uchun va ixtiyoriy $b > 0$ sonda $a^x = b$ bo'ladigan birgina $x \in R$ soni mavjud bo'lgani uchun $E(f) = R_+$ bo'ladi.

Xossalari:

1) $a > 1$ bo'lsa, $f(x) = a^x$ funksiya R da o'sadi. $0 < a < 1$ bo'lsa, $f(x) = a^x$ funksiya R da kamayadi.

I s b o t . $a > 1$ holni qarash bilan cheklanamiz. $a > 1$ va $\alpha < \beta$ bo'lsin, bu yerda α , β sonlari ixtiyoriy haqiqiy sonlar. U holda $\beta - \alpha > 0$, $a > 1$ bo'lgani uchun $a^{\beta - \alpha} > a^0$ yoki $a^{\beta - \alpha} > 1$ tengsizlikka ega bo'lamiz. Bundan, $a^{\beta - \alpha} \cdot a^\alpha > 1 \cdot a^\alpha$ yoki $a^\beta > a^\alpha$ hosil bo'ladi. Demak, $\alpha < \beta$ dan $a^\alpha < a^\beta$ ekani kelib chiqadi. Bu esa a^x funksiya o'suvchi ekanligini bildiradi.

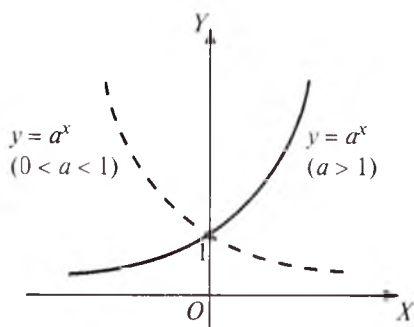

70- rasm.

70- rasmda $y = a^x$ ko'rsatkichli funksiyaning sxematik grafigi tasvirlangan.

Agar $a > 1$ bo'lsa, $x \rightarrow +\infty$ da a^x cheksiz ortadi, $x \rightarrow -\infty$ da a^x nolgacha kamayadi. Demak, a^x grafigi $y = 0$ to'g'ri chiziqqa tomon cheksiz yaqinlashadi, ya'ni Ox o'qi funksiya grafigining *gorizontal asimptotasi*. Shu kabi $0 < a < 1$ bo'lganda, a^x funksiya

$+\infty$ dan 0 gacha kamayadi, Ox o'qi – gorizontal asimptota;

2) f funksiya juft ham, toq ham emas. Haqiqatan,

$$f(-x) = a^{-x} = \frac{1}{a^x} \neq \begin{cases} a^x, \\ -a^x; \end{cases} \quad f(-x) \neq \begin{cases} f(x), \\ -f(x); \end{cases}$$

3) f davriy funksiya emas, chunki ixtiyoriy $T \neq 0$ da $a^x \neq a^{x+T}$;

4) x ning hech qanday qiymatida a^x nolga aylanmaydi;

5) *funksionallik xossasi*: har qanday x va z da $f(x+z) = f(x) \cdot f(z)$ tenglik o'rinli. Chunki $a^{x+z} = a^x \cdot a^z$. Xuddi shunday $f(x)/f(z) = f(x-z)$ ekanligi isbotlanadi.

Misol. $f(x) = a^x$ ($a > 0$, $a \neq 1$) ko'rinishdagi uzluksiz funksiyaning ayrim qiymatlari jadvalda berilgan:

x	1	2	3	4
y	3	9	27	81

Funksiyaning analitik ifodasini tuzamiz.

Yechish. $f(1) = 3$, $f(2) = 9$, $f(1+2) = f(3) = 27$ va $f(1) \cdot f(2) = 3 \cdot 9 = 27$, ya'ni (5) xossa bajarilmoqda. Qolgan qiymatlar ham shu natijani beradi. Demak, $f(x)$ bog'lanish ko'rsatkichli funksiya. Uning asosi a ni aniqlaymiz: $y = a^x$ tenglikdagi x va y o'rniga jadval qiymatlaridan biror juftni, masalan, (1; 3) ni qo'ysak, $a^1 = 3$, ya'ni $a = 3$ olinadi. Demak, izlanayotgan ifoda $y = 3^x$.



Mashqlar

8.7. $1, q, q^2, \dots, q^n, \dots$ geometrik progressiyaning $u_k = \sqrt{u_{k-j}u_{k+j}}$ asosiy xossasi $f(x) = a^x$ ko'rsatkichli funksiyaning $f(x) \cdot f(y) = f(x+y)$ xossasidan foydalanib isbot qilinsin. Bu yerda $k, j \in N, k > j$.

8.8. Quyidagi funksiyalar grafiklarini $[-2; 1]$ oraliqda yasang:

a) $y = 4^x$; b) $y = 3^x$; d) $y = 2^x$;

e) $y = -3 \cdot 3^x$; f) $y = -2 \cdot 3^x$.

8.9. Tenglamalarni yeching:

a) $5^x = 125$; b) $3^{1+x} = 81$; d) $0,01^x = 100$.

8.10. Ifodalarni soddalashtiring:

a) $(9^x)^2 - 3 \cdot 9^{2x} + 9^{2x+1} = 0$; b) $2^{8x} \cdot 3^x + 12^x - 2^{8x+1} \cdot 6^x$;

d) $a^{2x} + 2a^x b^x + b^{2x} - (a^x - b^x)^2$.

8.11. Jadvalda $y = f(x)$ uzluksiz funksiyaning bir necha qiymati keltirilgan. Ular $y = A \cdot a^x$ ($A \in R, a > 0, a \neq 1$) ko'rinishdagi funksiyaning ifodalashini tushuntiring, funksiyaning analitik ifodasini tuzing:

a)

x	1	2	3
y	0.2	0.04	0.008

b)

x	1	3	5	7
y	-2	-8	-32	-128

8.12. a) Bankka 1000 so'm pul har yili 10% ga o'sish sharti bilan qo'yilgan. Mablag'ning o'sish tenglamasini tuzing. Tenglamadan foydalanib, mablag'ning 3, 5, 10 yildan keyin qanchaga teng bo'lishini toping.

b) Korxonaning har t yilda pul qadr-qiymati o'zgarishi ham e'tiborga olingan, ya'ni diskontlangan D_t daromadini bilish uchun $D_t = D \cdot K_d$ tenglikdan foydalaniladi, bunda D - mo'ljal bo'yicha har yilgi daromad, K_d - diskontlash koeffitsiyenti, $K_d = \frac{1}{(1+k)^t}$, k - pul qiymatining o'zgarish

sur'ati (odatda bank kreditlari bo'yicha o'rtacha % larda). Bank $k = 10\%$ hisobidan kredit bergan bo'lsin.

1) $t = 1, 2, 3, 4$ - yillar uchun K_d koeffitsiyentlarni toping.

2) Kredit uchun to'lovi bo'lmagan korxonada daromadi 1- yilda 30000 so'm, 2- yilda 40000 so'm, 3- yilda 50000 so'm, 4- yilda 60000 so'm bo'lganda uning $t = 1, 2, 3, 4$ - yillardagi diskontlangan daromadi qanday bo'ladi?

3) Agar korxonada bankdan 100000 so'm kredit olgan bo'lsa, uni qancha vaqtdan keyin qaytara oladi?

8.13. Radioaktiv moddaning massasi 1- yilda 8 g ga, 4- yilda 1 g ga teng bo'lgan. Bu massa bir yilda qancha marta o'zgargan? Massaning boshlang'ich, undan 4 yil oldingi, 7,5- yildagi qiymati qancha bo'lgan?

8.14. 10 sm uzunlikdagi xira muhitdan o'tishda yorug'lik kuchi uch martaga kamaygan. U 5, 20, 25 sm uzunlikdagi oraliqlarda necha marta kamayadi?

2- §. Logarifmik funksiya

1. Logarifmlar. Logarifmik funksiya. $a > 0, a \neq 1$ bo'lsin. N sonining a asos bo'yicha *logarifmi* deb, N sonini hosil qilish uchun a sonini ko'tarish kerak bo'lgan daraja ko'rsatkichiga aytiladi va $\log_a N$ bilan belgilanadi. Ta'rifga ko'ra, $a^x = N$ ($a > 0, a \neq 1$) tenglamaning x yechimi $x = \log_a N$ sonidan iborat. Ifodaning logarifmini topish amali shu ifodani *logarifmlash*, berilgan logarifmiga ko'ra shu ifodaning o'zini topish esa *potensirlash* deyiladi. $x = \log_a N$ ifoda potencirlansa, qaytadan $N = a^x$ hosil bo'ladi. $a > 0, a \neq 1$ va $N > 0$ bo'lgan holda $a^x = N$ va $\log_a N = x$ tengliklar teng kuchlidir.

Shu tariqa biz o'zining aniqlanish sohasida uzluksiz va monoton bo'lgan $y = \log_a x$ ($a > 0, a \neq 1$) funksiyaga ega bo'lamiz. Bu funksiya a asosli *logarifmik funksiya* deyiladi. $y = \log_a x$ funksiya $y = a^x$ funksiyaga teskari funksiyadir. Uning grafigi $y = a^x$ funksiya grafigini $y = x$ to'g'ri chiziqqa nisbatan simmetrik almashtirish bilan hosil qilinadi (71- rasm). Logarifmik funksiya ko'rsatkichli funksiyaga teskari funksiya bo'lganligi sababli, uning xossalari ko'rsatkichli funksiya xossalariidan foydalanib hosil qilish mumkin.

Jumladan, $f(x) = a^x$ funksiyaning aniqlanish sohasi $D(f) = \{-\infty < x < +\infty\}$, o'zgarish sohasi $E(f) = \{0 < y < +\infty\}$ edi. Shunga ko'ra $f(x) = \log_a x$ funksiya uchun $D(f) = \{0 < x < +\infty\}$, $E(f) = \{-\infty < y < +\infty\}$ bo'ladi. $a > 1$ da $\log_a x$ funksiya $(0; +\infty)$ nurda uzluksiz, o'suvchi, $0 < x < 1$ da manfiy, $x > 1$ da musbat, $-\infty$ dan $+\infty$ gacha o'sadi. Shu kabi $0 < a < 1$ da funksiya $(0; +\infty)$ da uzluksiz, $+\infty$ dan 0 gacha kamayadi, $0 < x < 1$ oraliqda musbat, $x > 1$ da manfiy qiymatlarni qabul qiladi. Ordinatalar o'qi $\log_a x$ funksiya uchun *vertikal asimptota*.

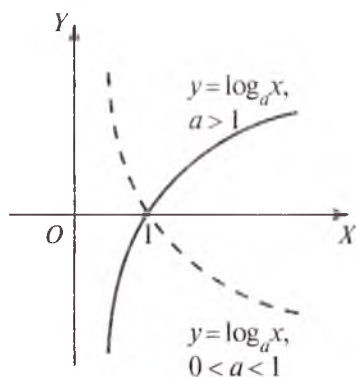

71- rasm.

Logarifmik funksiyaning qolgan xossalarini isbotlashda ushbu *asosiy logarifmik ayniyatdan* ham foydalaniladi:

$$a^{\log_a N} = N \quad (N > 0, a > 0, a \neq 1). \quad (1)$$

(1) ayniyat $a^x = N$ tenglikka $x = \log_a N$ ni qo'yish bilan hosil qilinadi. O'zgaruvchi qatnashgan $a^{\log_a x} = x$ tenglik x ning $x > 0$ qiymatlaridagina o'rinli bo'ladi. $x \leq 0$ da $a^{\log_a x} = x$ ifoda ham o'z ma'nosini yo'qotadi. $y = x$ va $y = a^{\log_a x}$ munosabatlar o'rtasidagi farqni 72- rasmdan tushunish mumkin.

1) $\log_a 1 = 0$, chunki $a^0 = 1$;

2) $\log_a a = 1$, chunki $a^1 = a$;

$$3) \log_a N = \frac{\log_c N}{\log_c a} \quad (c > 0, c \neq 1). \quad (2)$$

Bu tenglik $N = a^c$ tenglikka $N = c^{\log_c N}$, $a = c^{\log_c a}$, $c = \log_a N$ larni qo'yish va almashtirishlarni bajarish orqali hosil bo'ladi;

$$4) \log_a (NM) = \log_a N + \log_a M. \quad (3)$$

Haqiqatan, $NM = a^{\log_a N} \cdot a^{\log_a M} = a^{\log_a N + \log_a M}$. Ikkinchi tomondan, $NM = a^{\log_a NM}$. Tengliklarning o'ng qismlari tenglashtirilsa, (3) tenglik hosil bo'ladi.

Agar N va M bir vaqtda manfiy bo'lsa, u holda:

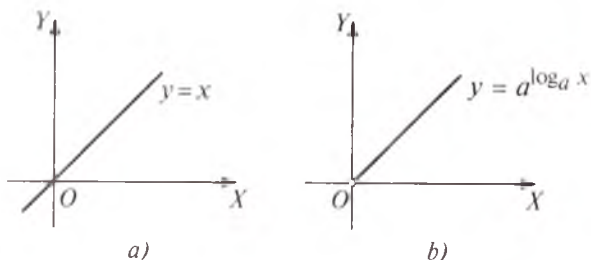

72- rasm.

$$\log_a(NM) = \log_a |N| + \log_a |M|;$$

$$5) \log_a \frac{1}{N} = -\log_a N. \quad (4)$$

Haqiqatan, $N \cdot \frac{1}{N} = 1$ tenglikni logarifmlasak:

$$\log_a \left(N \cdot \frac{1}{N} \right) = \log_a 1 \text{ yoki } \log_a N + \log_a \frac{1}{N} = 0,$$

bundan (4) tenglik hosil bo'ladi;

$$6) \log_a \frac{N}{M} = \log_a N - \log_a M. \quad (5)$$

Haqiqatan, $\log_a \frac{N}{M} = \log_a N + \log_a \frac{1}{M} = \log_a N - \log_a M$;

$$7) \log_a N^\beta = \beta \log_a N, \beta - \text{haqiqiy son.} \quad (6)$$

Haqiqatan, $x = \log_a N^\beta$ va $y = \log_a N$ bo'lsin. Ta'rifga ko'ra $N^\beta = a^x$ va $N = a^y$ yoki $N^\beta = a^{\beta y}$. Bulardan $a^x = a^{\beta y}$ yoki $x = \beta y$ va (6) tenglik hosil bo'ladi;

$$8) \log_{a^\beta} N = \frac{1}{\beta} \log_a N. \quad (7)$$

Haqiqatan, a^β asosdan a asosga o'tilsa,

$$\log_{a^\beta} N = \frac{1}{\log_a a^\beta} \cdot \log_a N = \frac{1}{\beta \log_a a} \log_a N = \frac{1}{\beta} \log_a N;$$

9) agar $a > 1$ bo'lsa, $M < N$ dan $\log_a M < \log_a N$ kelib chiqadi (va aksincha). Haqiqatan, $(M < N) \Rightarrow (a^{\log_a M} < a^{\log_a N}) \Rightarrow$ (darajaning xossasi) $(\log_a M < \log_a N)$ (va aksincha). Shu kabi.

agar $0 < a < 1$ bo'lsa, $\log_a M < \log_a N$ bo'lganda $M > N$ bo'ladi (va aksincha);

10) agar $\log_a M = \log_a N$ bo'lsa, $M = N$ bo'ladi (va aksincha).

Haqiqatan, $(\log_a M = \log_a N) \Rightarrow (a^{\log_a M} = a^{\log_a N}) \Rightarrow (M = N)$.

1- misol. $A = \log_3 9 - \log_{\sqrt{3}} 9 - \log_{\frac{\sqrt{3}}{2}} \left(\frac{64}{9}\right) - \log_{\frac{1}{3}} 9$ ifodaning son qiymatini toping.

Yechish. Logarifmning yuqorida isbotlangan xossalaridan foydalanib, ifodadagi har bir logarifmning qiymatini topib olamiz:

$$\log_3 9 = \log_3 3^2 = 2 \log_3 3 = 2 \cdot 1 = 2;$$

$$\log_{\sqrt{3}} 9 = \log_{\frac{1}{2}} 3^2 = \frac{2}{\frac{1}{2}} \cdot \log_3 3 = 2 \cdot 2 \cdot 1 = 4;$$

$$\log_{\frac{1}{3}} 9 = \frac{\log_3 9}{\log_3 \frac{1}{3}} = \frac{2}{-1} = -2;$$

$$\begin{aligned} \log_{\frac{\sqrt{3}}{2}} \left(\frac{64}{9}\right) &= \frac{\log_3 \left(\frac{64}{9}\right)}{\log_3 \frac{\sqrt{3}}{2}} = \frac{\log_3 64 - \log_3 9}{\log_3 \sqrt{3} - \log_3 2} = \frac{6 \log_3 2 - 2 \cdot 1}{\frac{1}{2} \log_3 \sqrt{3} - \log_3 2} = \\ &= \frac{4(3 \log_3 2 - 1)}{1 - 2 \log_3 2}. \end{aligned}$$

$$\text{Demak, } A = \frac{4(3 \log_3 2 - 1)}{1 - 2 \log_3 2}.$$

Amaliyotda asosi 10 bo'lgan (*o'nli* logarifmlar) va asosi $e = 2,7182818\dots$ ga teng bo'lgan (*natural* logarifmlar) logarifmlar keng qo'llaniladi. Ularni mos ravishda $\lg N$ va $\ln N$ ko'rinishda belgilash qabul qilingan. Son o'nli logarifmining butun qismi logarifmning *xarakteristikasi*, kasr qismi logarifmning *mantisasi* deyiladi. Masalan, $\lg 2 = 0,3010$ da xarakteristika 0 ga, mantissa 0,3010 ga teng. $\lg 2000 = \lg 2 \cdot 10^3 = 3 \lg 10 + \lg 2 = 3,3010$ da xarakteristika 3 ga, mantissa 0,3010 ga teng. $\lg 0,2 = \lg 2 \cdot 10^{-1} = \lg 2 - 1 = 0,3010 - 1 = -1 + 0,3010$ da xarakteristika -1 , mantissa 0,3010. Odatda, mantissa musbat qiymatlarda yoziladi.

Agar logarifm qiymati manfiy bo'lsa, mantissani musbat qilish uchun shu qiymatga 1 qo'shiladi, umumiy qiymat o'zgarmasligi uchun xarakteristikadan 1 olinadi va logarifm qiymati *sun'iy* ko'rinishda yoziladi. Masalan,

$$\lg 0,2 = -0,6990 + 1 - 1 = \bar{1},3010,$$

bunda xarakteristika -1 ga, mantissa esa $0,3010$ ga teng.

2- misol. a) $\ln 10 = \frac{\lg 10}{\lg e} = \frac{1}{\lg e} = 2,30259\dots;$

$$\lg e = \frac{\ln e}{\ln 10} = \frac{1}{\ln 10} = 0,43429\dots$$

3- misol. a) $\lg 1000^{67}$; b) $\ln e^{4,8}$ larni hisoblang.

Yechish: a) $\lg 1000^{67} = \lg 10^3 \cdot 67 = \lg 10^{201} = 201 \cdot \lg 10 = 201 \cdot 1 = 201;$

b) $\ln e^{4,8} = 4,8 \ln e = 4,8 \cdot 1 = 4,8.$

4- misol. Jadvalda $\lg 3 = 0,4771$ ekanligi berilgan. a) $\lg 270$ ni; b) 3^{1000} ni toping.

Yechish: a) $\lg 270 = \lg 3^3 \cdot 10 = 3 \lg 3 + \lg 10 = 3 \cdot 0,4771 + 1 = 2,4313.$

b) $3^{1000} = x$ deb, bu tenglikni logarifmlasak, $\lg x = 1000 \lg 3 \approx 477,1$ yoki bundan $x \approx 10^{477,1}$ hosil bo'ladi.

Demak, $3^{1000} = 10^{477,1} \approx 1 \underbrace{000\dots 0}_{477 \text{ ta}}$.

5- misol. Ushbu $X = \sqrt[3]{\frac{(x^3+1)^4(y^6+1)^7}{(x^4+y^2)^5}} \cdot e^{3\sin x} \cdot \sqrt{c}$ ifodani c asos bo'yicha logarifmlang.

Yechish.
$$\log_c X = \log_c \left(\frac{(x^3+1)^{\frac{4}{3}}(y^6+1)^{\frac{7}{3}}}{(x^4+y^2)^{\frac{5}{3}}} \cdot e^{3\sin x} \cdot c^{\frac{1}{2}} \right) =$$

$$= \frac{4}{3} \log (x^3 + 1) + \frac{7}{3} \log_c (y^6 + 1) - \frac{5}{3} (x^4 + y^2) + 3 \sin x + \frac{1}{2}.$$

6-misol. $\lg X = \frac{3}{4} \lg(x^2 + 4y - 1) - \frac{3 \operatorname{tg} 4x}{4} - 2 \lg(x - 3)$ ifoda bo'yicha X ni toping.

Yechish. Logarifmning xossalaridan va $\lg 4x = \lg 10^{\operatorname{tg} 4x}$ ekanligidan foydalanib, $\lg X = \frac{3}{4} \lg(x^2 + 4y - 1) - \frac{3}{4} \operatorname{tg} 10^{\operatorname{tg} 4x} -$

$$-\frac{8}{4} \lg(x - 3) = \frac{1}{4} \lg \frac{(x^2 + 4y - 1)^3}{10^{3 \operatorname{tg} 4x} \cdot (x - 3)^8}$$
 ga ega bo'lamiz. Bundan,

$$X = \sqrt[4]{\frac{(x^2 + 4y - 1)^3}{10^{3 \operatorname{tg} 4x} \cdot (x - 3)^8}}$$
 hosil bo'ladi.



Mashqlar

8.15. $a > 0$, $a \neq 1$ bo'lsa, ifodaning qiymatini toping:

- a) $\log_{a^3} a$; b) $\log_a a^{\frac{1}{3}}$; d) $\log_{\frac{1}{a}} a^7$;
 e) $\log_{\sqrt{a}} \sqrt[3]{a}$; f) $\log_{a^{-1}} \sqrt{a}$; g) $\log_{a^2} a^{-5}$.

8.16. x ni toping:

- a) $\log_{0,1} x = -2$; b) $\log_{36} x = \frac{1}{2}$;
 d) $\log_x 9 = -1$; e) $\log_{\sqrt{x}} 8 = 3$.

8.17. $a > 0$, $a \neq 1$ va $x_1 > 0$, $x_2 > 0$, ..., $x_n > 0$ bo'lsa,

$$\log_a (x_1 x_2 \dots x_n) = \sum_{i=1}^n \log_a x_i$$
 ni isbotlang.

8.18. $\log_a x^{2n} = 2n \log_a |x|$ ($a > 0$, $a \neq 1$, $n \in \mathbb{N}$) munosabatni isbotlang.

8.19. $\frac{\log_a x}{\log_b x} = \log_a b$ tenglikni isbotlang ($a > 0$, $a \neq 1$, $b > 0$, $b \neq 1$, $x > 0$, $x \neq 1$).

8.20. Hisoblang:

- a) $\log_{4\sqrt{3}} 81$; b) $\log_{16} \sqrt{2}$; d) $\log_{0,001} \sqrt[6]{10}$;
 e) $\log_{\sqrt{2}} \frac{1}{64}$; f) $\frac{9^{\log_9 48}}{8^{\log_8 16}}$;

g) $(\log_2 \log_4 \log_8 16) \cdot 10^{\frac{1}{2} \lg 4 - \lg 2 + \lg 0.1}$; h) $\frac{\lg 81 + \lg 64}{2 \lg 3 + 3 \lg 2}$;

i) $\log_2 3 \cdot \log_3 4 \cdot \log_4 5 \cdot \log_5 6 \cdot \log_6 5 \cdot \log_5 4 \cdot \log_4 3 \cdot \log_3 2$;

j) $\lg 6$; k) $\lg 72$.

8.21. Agar: a) $\log_6 8 = c$ bo'lsa, $\log_{24} 72$;

b) $\log_{36} 8 = b$ bo'lsa, $\log_{36} 9$;

d) $\log_{1000} 9 = a$ va $\log_{1000} 4 = b$ bo'lsa, $\log_5 6$ ni toping.

8.22. Tengsizlik a ning qanday qiymatlarida o'rinni:

a) $\log_5 a < \log_5 3a$; b) $\log_{0.6} a > \log_{0.6} \frac{a}{2}$;

d) $\log_a \sqrt{8} < \log_a 2.2$?

8.23. Funktsiyalarning va ularga teskari funktsiyalarning aniqlanish sohalarini toping:

a) $y = \lg(x^2 + 6x)$; b) $y = \lg(10^{3x} + 3)$;

d) $y = 10^{x^2+2x}$; e) $y = \frac{1}{\lg \sqrt{x+2}}$;

f) $y = \log_2(x-8) + \log_2(8-x)$.

8.24. $x \rightarrow +\infty$ da qaysi funksiya tezroq o'sadi:

a) $\log_4 x$ mi yoki $\log_2 x$ mi;

b) $\log_{\frac{1}{5}} x$ mi yoki $\log_{\frac{1}{2}} x$ mi?

Ulardan qaysilari $0 < x < 1$ da ikkinchisidan katta?

8.25. Funktsiyalarning grafigini yasang:

a) $\log_{0.5}|x|$; b) $|\log_3 x|$; d) $|\lg(x+1)|$.

8.26. Quyidagi ifodalar bilan berilgan chiziqlarni chizing:

a) $|y| = \lg(x+3)$; b) $|y| = |\lg(x+1)|$.

8.27. Agar $a^2 + b^2 + 18ab$, $a > b$ bo'lsa, $\lg \frac{a-b}{4} = \frac{1}{2}(\lg a + \lg b)$ bo'lishini isbot qiling.

8.28. Ikki N va M sonning istalgan asos bo'yicha logarifmlari nisbatlari teng, ya'ni

$$\frac{\log_a N}{\log_a M} = \frac{\log_b N}{\log_b M} = \dots = \frac{\log_c N}{\log_c M}$$

bo'lishini isbot qiling.

8.29. Agar biror $y = f(x)$ funksiyaning teng qadamli jadvalida funksiyaning yonma-yon turgan qiymatlari nisbatlari teng bo'lsa, jadval $y = A \cdot a^x$ funksiyani ifodalaydi. Shuni isbot qiling (bunda logarifmlarning xossalaridan foydalaning).

8.30. Tebrangich x (sm) erkin tebranish amplitudasining tebranish boshlangandan o'tgan t (s) ga bog'liqligi kuzatilib, ushbu jadval tuzilgan:

x	0	1	2	3	4	5
t	30,3	15,0	7,50	3,75	1,875	0,9375

$x = f(t)$ bog'lanish grafigini chizing va analitik ifodasini tuzing.

2. Ko'rsatkichli va logarifmik ifodalarni ayniy almashtirishlar.

Oldingi bandlarda logarifmning va logarifmik funksiyaning, shuningdek, darajaning va ko'rsatkichli funksiyaning xossalari bilan tanishgan edik. Bu xossalardan logarifmik va ko'rsatkichli ifodalarni shakl almashtirishlarda foydalaniladi.

1-misol. $3^{2+\log_3 2}$ ni hisoblang.

Yechish. $3^{2+\log_3 2} = 3^2 \cdot 3^{\log_3 2} = 9 \cdot 2 = 18$.

2-misol. $a^{\log_b c} = c^{\log_b a}$ ($a > 0$, $a \neq 1$, $b > 0$, $b \neq 0$, $c > 0$) tenglikni isbotlang.

Isbot. Logarifmning $\log_a b^p = p \cdot \log_a b$ ($a > 0$, $a \neq 1$, $b > 0$, $p \in \mathbb{R}$) xossasidan foydalansak, $\log_b a \cdot \log_b c = \log_b a \cdot \log_b c$ tenglikdan $\log_b (a^{\log_b c}) = \log_b (c^{\log_b a})$ tenglikni hosil qilamiz. Logarifmik funksiyaning monotonlik xossasidan $a^{\log_b c} = c^{\log_b a}$ ekanligi kelib chiqadi.

3-misol. $a^{\sqrt{\log_a b}} - b^{\sqrt{\log_b a}}$ ifodani soddalashtiring.

Yechish. $a^{\sqrt{\log_a b}}$ ifodada shakl almashtirish bajaramiz:

$$a^{\sqrt{\log_a b}} = a^{\frac{\log_a b}{\sqrt{\log_a b}}} = (a^{\log_a b})^{\frac{1}{\sqrt{\log_a b}}} = b^{\frac{1}{\sqrt{\log_a b}}} = b^{\sqrt{\log_b a}}.$$

Demak, $a^{\sqrt{\log_a b}} - b^{\sqrt{\log_b a}} = 0$.

4- misol. $A = \log_4 \frac{x^2}{4} - 2 \log_4 (4x^4)$ ifodani soddalashtiring va uning $x = -2$ dagi qiymatini toping.

Yechish. $\log_a b^{2n} = 2n \log |b|$ ($a > 0$, $a \neq 1$, $b \neq 0$, $n \in \mathbb{N}$) bo'lgani uchun $\log_4 \frac{x^2}{4} = \log_4 x^2 - \log_4 4 = 2 \log_4 |x| - 1$ va $\log_4 (4x^4) = \log_4 4 + \log_4 x^4 = 1 + 4 \log_4 |x|$ tengliklar o'rinli.

U holda, $A = 2 \log_4 |x| - 1 - 2(1 + 4 \log_4 |x|) = -3 - 6 \log_4 |x|$. $x = -2$ bo'lsa, $A = -3 - 6 \log_4 |-2| = -3 - 6 \log_4 2 = -6$.

5- misol. $A = \frac{(\lg b \cdot 2^{\log_2 (\lg b)^2})^{\frac{1}{2}} \lg^{\frac{1}{2}} b^2}{\sqrt{\frac{\lg^2 b + 1}{2 \lg b} + 1 - 10^{0,5 \lg (\lg^2 b)}}}$ ifodani soddalashtiring.

Yechish. Musbat sonlarga logarifmga ega bo'lgani uchun $\lg b > 0$ yoki $b > 1$ munosabatga ega bo'lamiz. Darajaning va logarifmning tegishli xossalariidan foydalanib, shakl almashtirishlar bajaramiz:

$$A = \frac{(\lg b \cdot \lg b)^{\frac{1}{2}} \lg^{\frac{1}{2}} b^2}{\sqrt{\frac{(\lg b + 1)^2}{2 \lg b} - \sqrt{\lg \sqrt{b}}}} = \frac{\lg b \cdot \frac{1}{\sqrt{\lg b^2}}}{\frac{\lg b + 1 - \sqrt{2 \lg b} \cdot \sqrt{\frac{1}{2} \lg b}}{\sqrt{\lg b^2}}} = \frac{\lg b}{\lg b + 1 - \lg b} = \lg.$$

6- misol. $y = \log_{\frac{1}{2}} \left(x - \frac{1}{2} \right) + \log_2 \sqrt{4x^2 - 4x + 1}$ funksiyaning grafigini yasang.

Yechish. Funksiya ifodasini soddalashtirmay, grafikni yasashga harakat qilish maqsadga muvofiq emas ekanligi ko'rinib turibdi. Shu sababli dastlab funksiyaning ifodasini soddalashtiramiz:

$$\begin{aligned} \log_2 \sqrt{4x^2 - 4x + 1} &= \log_2 \sqrt{(2x - 1)^2} = \\ &= \log_2 |2x - 1| = \log_2 \left(2 \cdot \left| x - \frac{1}{2} \right| \right) = \\ &= 1 + \log_2 \left| x - \frac{1}{2} \right| \end{aligned}$$

tenglik o'rinlidir. Bu yerda funksiyaning aniqlanish sohasi

$\left(\frac{1}{2}; +\infty \right)$ oraliqdan iboratligini

ko'ramiz. $x > \frac{1}{2}$ da esa

$$\log_{\frac{1}{2}} \left(x - \frac{1}{2} \right) = -\log_2 \left(x - \frac{1}{2} \right) \text{ bo'lgani uchun}$$

$$\begin{aligned} y &= \log_{\frac{1}{2}} \left(x - \frac{1}{2} \right) + \log_2 \sqrt{4x^2 - 4x + 1} = -\log_2 \left(x - \frac{1}{2} \right) + \\ &+ \left(1 + \log_2 \left| x - \frac{1}{2} \right| \right) = -\log_2 \left(x - \frac{1}{2} \right) + 1 + \log_2 \left| x - \frac{1}{2} \right| = 1 \end{aligned}$$

ga ega bo'lamiz.

Endi funksiya grafigini yasash (73-rasm) qiyinchilik tug'dirmaydi.

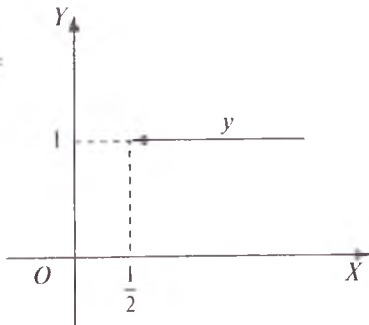

73- rasm.



Mashqlar

8.31. Ifodani soddalashtiring:

$$\text{a) } \sqrt{25^{\frac{1}{\log_6 5}} + 49^{\frac{1}{\log_5 7}}}; \quad \text{b) } 81^{\frac{1}{\log_9 3}} + 27^{\log_9 36} + 3^{\frac{4}{\log_7 9}};$$

$$\text{d) } \left(b^{\frac{\log_{100} a}{\lg a}} + a^{\frac{\log_{100} b}{\lg b}} \right)^{2 \log_{ab} (a+b)};$$

$$\text{e) } \left(\left(\log_b^4 a + \log_a^4 b + 2 \right)^{\frac{1}{2}} + 2 \right)^{\frac{1}{2}} - \log_b a - \log_a b.$$

8.32. x ni toping:

a) $\log_3 x = 2 \log_3 (a + b) - \frac{2}{3} \log_3 (a - b) + \frac{1}{2} \log_3 a$;

b) $\log_4 x = \log_4 (a - b) + \frac{1}{3} (2 \log_4 a + 3 \log_4 b)$;

d) $\log_5 x = 5 \log_5 m + \frac{1}{2} \left(\log_5 (m+n) + \frac{1}{3} \log_5 (m-n) - \log_5 m - \log_5 n \right)$;

e) $\log_6 x = -\log_6 (a + b) + \frac{2}{5} \left[2 \log_6 a + \frac{1}{2} \log_6 b - \frac{1}{3} (\log_6 a - \log_6 b) - \log_6 a \right]$.

8.33. Sonning musbat yoki manfiy ekanini aniqlang:

a) $\lg 2 + \lg 3 + \lg 0,16$;

b) $\log_{\frac{1}{5}} 7 - \frac{1}{2} \log_{\frac{1}{5}} 1,2 - 3 \log_{\frac{1}{5}} 2$;

d) $\frac{1}{2} \log_{11} 5 + \frac{1}{2} \log_{11} 3 - \log_{11} 4,5$;

e) $\lg 4 + \lg 12 - 2 \lg 7$;

f) $\log_3 3 + \log_3 1,4 - \frac{1}{2} \log_3 16$;

g) $1 + 2 \lg 2 - 3 \lg 5 + \lg 3$.

8.34. Hisoblang:

a) $\frac{\log_3 12}{\log_{36} 3} - \frac{\log_3 4}{\log_{108} 3}$;

b) $\lg \lg 1^\circ \cdot \lg \lg 2^\circ \cdot \dots \cdot \lg \lg 89^\circ$;

d) $\lg 5 - \lg 20 + (\lg 2)^2$;

e) $\lg \sin 1^\circ \cdot \lg \sin 2^\circ \cdot \dots \cdot \lg \sin 90^\circ$;

f) $\frac{\log_5 250}{\log_{50} 5} - \frac{\log_5 10}{\log_{1250} 5}$;

g) $\lg \lg 1^\circ + \lg \lg 2^\circ + \dots + \lg \lg 89^\circ$;

h) $\frac{\log_2 24}{\log_{96} 2} - \frac{\log_2 192}{\log_{12} 2}$;

i) $7^{\log_3 5} + 3^{\log_5 7} - 5^{\log_3 7} - 7^{\log_5 3}$;

j) $4^{5 \log_4 \sqrt{2} (3 - \sqrt{6})} - 6 \log_8 (\sqrt{3} - \sqrt{2})$;

k) $2^{\log_2 \sqrt{2} (5 - \sqrt{10})} + 8 \log_{\frac{1}{4}} (\sqrt{5} - \sqrt{2})$.

8.35. Funksiya grafigini yasang:

a) $y = x^{\frac{1}{\lg x}}$; b) $y = 9^{\log_{\sqrt{3}}|x^2 - 5x + 6|}$;

d) $y = 3^{2 \log_3(x-1)}$; e) $y = x + x^{\frac{1}{\lg x}}$.

8.36. $\frac{\log_3 135}{\log_{15} 3} - \frac{\log_3 5}{\log_{405} 3}$ ni jadvalsiz hisoblang.

8.37. $\lg 2 = a$, $\log_2 7 = b$ bo'lsa, $\lg 56$ ni toping.

8.38. $\lg 3 = a$, $\lg 2 = b$ bo'lsa, $\log_5 6$ ni toping.

8.39. $\log_3 7 = a$, $\log_7 5 = b$, $\log_5 4 = c$ bo'lsa, $\log_3 12$ ni toping.

8.40. Agar $b = 8^{\frac{1}{1 - \log_8 a}}$ va $c = 8^{\frac{1}{1 - \log_8 b}}$ bo'lsa, $\log_8 a$ ni $\log_8 c$ orqali ifodalang.

3- §. Ko'rsatkichli va logarifmik tenglamalar, tengsizliklar

1. **Ko'rsatkichli tenglamalar va tengsizliklar.** $a^x = b$ ($a, b \in R$) tenglama eng sodda ko'rsatkichli tenglamadir, bu yerda $a > 0$, $a \neq 1$.

Ko'rsatkichli funktsiyaning qiymatlar to'plami $(0; +\infty)$ oraliqdan iborat bo'lgani uchun $b \leq 0$ bo'lganda qaralayotgan tenglama yechimga ega bo'lmaydi. Agar $b > 0$ bo'lsa, tenglama yagona yechimga ega va bu yechim $x = \log_a b$ sonidan iborat bo'ladi (74-rasm).

Teorema. Agar $a > 0$, $a \neq 1$ bo'lsa,

$$a^f(x) = a^{g(x)} \quad (1)$$

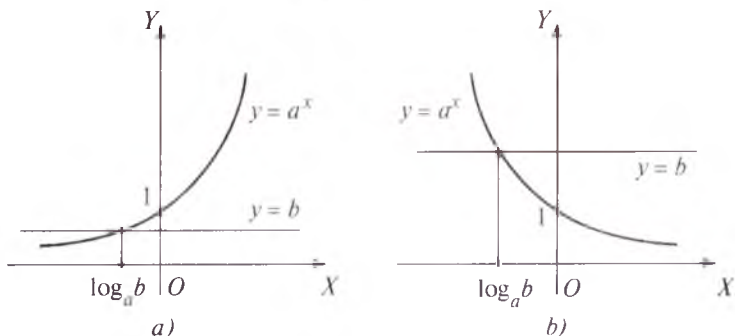

74- rasm.

$$f(x) = g(x) \quad (2)$$

tenglamalar teng kuchlidir.

Isbot. Agar α soni (2) tenglamaning ildizi bo'lsa, $f(\alpha) = g(\alpha)$ bo'ladi. U holda, $a^{f(\alpha)} = a^{g(\alpha)}$. Aksincha, α (1) tenglamaning ildizi bo'lsa, $a^{f(\alpha)} = a^{g(\alpha)}$ va a^x funksiyaning monotonligidan $f(\alpha) = g(\alpha)$ bo'ladi. Teorema isbot qilindi.

1-misol. $8^{5x^2-46} = 8^{2(x^2+1)}$ tenglamani yeching.

Yechish. Tenglama (1) ko'rinishda berilgan. Unga teng kuchli (2) ko'rinishga o'tamiz: $5x^2 - 46 = 2(x^2 + 1)$, bundan $x = -4$, $x = 4$ aniqlanadi.

Agar tenglama

$$a^{f(x)} = b^{g(x)} \quad (3)$$

(bu yerda $a > 0$, $a \neq 1$, $b > 0$, $b \neq 0$) ko'rinishda bo'lsa, $b^{g(x)} = a^{\log_a(b^{g(x)})} = a^{g(x)\log_a b}$ ekanidan foydalanib, tenglamani

$$a^{f(x)} = a^{g(x)\log_a b}$$

ko'rinishga keltiramiz. Bundan unga teng kuchli $f(x) = g(x)\log_a b$ tenglamaga o'tiladi.

2-misol. $5^{3x-1} = 3x$ tenglamani yechamiz.

Yechish. $5^{3x-1} = 5^{x\log_5 3} \Rightarrow 3x - 1 = x\log_5 3 \Rightarrow x = \frac{1}{3-\log_5 3}$.

Agar tenglama $f(a^x) = 0$ ko'rinishda bo'lsa, $a^x = t$ almashtirish orqali $f(t) = 0$ tenglamaga o'tiladi. Har vaqt $a^x > 0$ bo'lgani uchun $f(t) = 0$ tenglamaning musbat ildizlarigina olinadi, so'ng $a^x = t$ bog'lanish yordamida berilgan tenglama ildizlari topiladi.

3-misol. $4^x + 2^x - 6 = 0$ tenglamani yechamiz.

Yechish. $2^x = t$ almashtirish $(2^x)^2 + 2^x - 6 = 0$ tenglamani $t^2 + t - 6 = 0$ kvadrat tenglamaga keltiradi. Uning yechimlari $t = -3$, $t = 2$. Musbat yechim bo'yicha $2^x = 2$ ni tuzamiz. Bundan $x = 1$.

Ko'rsatkichli tengsizliklarni yechishda $y = a^x$ funksiyaning monotonligidan foydalaniladi. $a^{f(x)} > a^{g(x)}$ tengsizlik, $a > 1$ bo'lsa, $f(x) > g(x)$ tengsizlikka, $0 < a < 1$ bo'lganda esa $f(x) < g(x)$ tengsizlikka teng kuchli.

4- misol. $0,5^{x^2+3x+7} < 0,5^{x^2+1}$ tengsizlikni yeching.

Yechish. $0 < 0,5 < 1$ bo'lgani uchun tengsizlik $x^2 + 3x + 7 > x^2 + 1$ algebraik tengsizlikka teng kuchli. Undan $x > -2$ aniqlanadi.

5- misol. $4^{0,75x^2-2x+1} > 16^{x^2}$ tengsizlikni yechamiz.

Yechish. $4^{0,75x^2-2x+1} > 16^{x^2}$ tengsizlikni $4^{0,75x^2-2x+1} > 4^{2x^2}$ ko'rinishida yozib olamiz. $a = 4 > 1$ bo'lgani uchun, tengsizlik o'ziga teng kuchli bo'lgan $0,75x^2 - 2x + 1 > 2x^2$ tengsizlikka keladi.

Javob: $-2 < x < 0,4$.

Agar tengsizlik $f(a^x) < 0$ ko'rinishda bo'lsa, $a^x = t$ almash-tirish uni $f(t) < 0$ ko'rinishga keltiradi.

6- misol. $9^x - 3^{x+1} - 4 < 0$ tengsizligini yechamiz.

Yechish. $3^x = t$ almashtirish tengsizlikni $t^2 - 3t - 4 < 0$ tengsizlikka keltiradi. Oxirgi tengsizlikning yechimi $(-1; 4)$ bo'yicha $-1 < 3^x < 4$ tengsizligini tuzamiz va yechamiz.

Javob: $-\infty < x < \log_3 4$.

7- misol. $a^{x-1} < a^{2x}$ ($a > 0$) tengsizlikni yechamiz.

Yechish. $a > 1$, $a = 1$ va $0 < a < 1$ bo'lgan hollarni alohida-alohida qaraymiz.

$0 < a < 1$ bo'lsa, berilgan tengsizlik $x - 1 > 2x$ tengsizlikka yoki $x < -1$ tengsizlikka teng kuchli. Demak, bu holda, $(-\infty; -1)$ oraliqdagi barcha sonlar va faqat shu sonlar tengsizlikning yechimi bo'ladi.

$a = 1$ bo'lsa, $1^{x-1} < 1^{2x}$ tengsizlikka ega bo'lamiz. Bu tengsizlik yechimga ega emas.

$a > 1$ bo'lsa, berilgan tengsizlik $x - 1 < 2x$ yoki $x > -1$ tengsizlikka teng kuchlidir. Demak, $a > 1$ bo'lsa, $(-1; +\infty)$ oraliqdagi barcha sonlar va faqat shu sonlar tengsizlikning yechimi bo'ladi.

Javob: $0 < a < 1$ bo'lsa, $x \in (-\infty; -1)$; $a = 1$ bo'lsa, \emptyset ; $a > 1$ bo'lsa, $x \in (-1; +\infty)$.



Mashqlar

8.41. Ko'rsatkichli tenglamalarni yeching:

a) $4^{x-1} - 2^x = 0$;

b) $5^x - 125 \cdot 5^{-x} = 20$;

- d) $3 \cdot \left(\frac{5}{6}\right)^{2x} - 2 \cdot \left(\frac{5}{6}\right)^x - 1 = 0$;
- e) $9^{-|x-2|} - 4 \cdot 3^{-|x-2|} - a = 0, a \in R$;
- f) $0,5^{x^2-20x-23,5} = \frac{8}{\sqrt{2}}$; g) $9^x + 4^{x-0,5} = 9^{x+0,5} + 2^{2x}$;
- h) $4^{\sqrt{x-8}} + 16 = 10 - 2^{\sqrt{x-8}}$;
- i) $4^1 + 3 + 5 + \dots + (2x-1) = 0,25^{-64}$;
- j) $a^x = |x+2|, a - \text{parametr}$;
- k) $3^{2x-3} \cdot 5^{3x-2} = \frac{5}{3}$; l) $3^x \cdot 5^{x-1} = 1$;
- m) $2^{x+4} + 2^{x+1} + 3 \cdot 2^{x+2} = 120$;
- n) $4^x - 7^{x+2} = 7^{x+1} - 2 \cdot 4^{x+1}$;
- o) $\frac{1}{2^{x^2-1}} + 2^{1-x^2} = 2$; p) $9 \cdot 4^x - 13 \cdot 6^x + 4 \cdot 9^x = 0$;
- q) $10 \cdot 4^x - 9 \cdot 2^x(4^x + 1) + 2(16^x + 2 \cdot 4^x + 1) = 0$;
- r) $4^x - 2 \cdot 6^x = 9^{x+\frac{1}{2}}$; s) $3 \cdot 4^x + 2 \cdot 25^x = 5 \cdot 10^x$;
- t) $\left(\sqrt{4+\sqrt{15}}\right)^x + \left(\sqrt{4-\sqrt{15}}\right)^x = 8$;
- u) $\left(\frac{3}{4}\right)^{x-2} \cdot \sqrt{\frac{4}{3}} = \frac{1}{2} \sqrt{3^{2x-7}}$; v) $\left(\frac{2}{5}\right)^x + \left(\frac{3}{5}\right)^x = 1$;
- x) $3^{x+1} = 11 - 2^x$; y) $2^x + 5^x = 7^x$;
- z) $2^{x+2} = \frac{5x+3}{x}$; o*) $2^{|x|+1} = 2 - x^2$.

8.42. Ko'rsatkichli tengsizliklarni yeching:

- a) $\left(\frac{1}{2}\right)^{x^4-5x^2} > 2^{-8x^2+6}$; b) $4^x - 4 \cdot 2^x + 3 > 0$;
- d) $3^{2(x+1)} - 5 \cdot 3^x + 2 < 0$;
- e) $|5^x - 5| - |5^x - 4| \geq |5^x + 4| - 8$;
- f) $a^{\frac{x-3}{x+1}} > a^{\frac{2x-1}{x+1}}$; g) $2^{x^2+4x+4} > 2$;

h) $2^x \cdot 3^{x-2} \geq \frac{2}{3}$;

i) $\left(\frac{2}{3}\right)^x - 2^{x+1} \geq 3^{-x} - 2$;

j) $2^{x+4} + 3 \cdot 2^{x-2} \geq 67$;

k) $4^x - 5 \cdot 2^x + 4 \geq 0$;

l) $0,1^{4x^2-2x-2} \leq 0,1^{2x-3}$;

m) $\frac{2^{x-1}-1}{2^{x+1}+1} < 2$;

n) $(0,3)^{2+4+6+\dots+2x} > (0,3)^{72}$, $x \in \mathbb{N}$;

o) $4^x - 2 \cdot 5^{2x} - 10^x > 0$;

p) $\sqrt{9^x - 3^{x+2}} > 3^x - 9$;

q) $x^2 \cdot 2^{2x} + 9(x+2) \cdot 2^x + 8x^2 \leq (x+2) \cdot 2^{2x} + 9x^2 \cdot 2^x + 8x + 16$;

r) $\left(\frac{1}{3}\right)^{x+\frac{1}{2}-\frac{2}{x}} = \frac{1}{\sqrt{27}}$;

s) $2^x + 2^{|x|} \geq 2\sqrt{2}$;

t) $0,2^{\frac{2x-3}{x-2}} > 5$;

u) $\left(\frac{1}{5}\right)^{\frac{2x+1}{1-x}} > \left(\frac{1}{5}\right)^{-3}$.

- 8.43. a ning qanday qiymatlarida $|x+1| - |3x+15| = a^x$ tenglama:
 a) yagona yechimga ega? b) bittadan ortiq yechimga ega bo'ladi? d) yechimga ega bo'lmaydi?

2. Logarifmik tenglamalar va tengsizliklar. $\log_a x = b$ ($a > 0$, $a \neq 1$) tenglamani qaraymiz. Bu tenglama eng sodda logarifmik tenglama deyiladi. $x = a^b$ son qaralayotgan tenglamaning ildizi bo'lishini ko'rish qiyin emas.

Berilgan tenglama $x = a^b$ dan boshqa ildizga ega emasligini $y = \log_a x$ logarifmik funksiyaning monotonligidan foydalanib isbotlash mumkin (75- rasm).

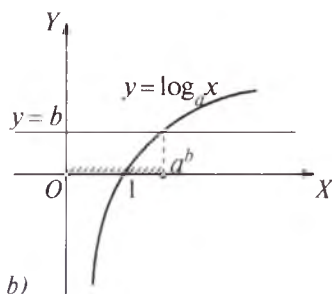
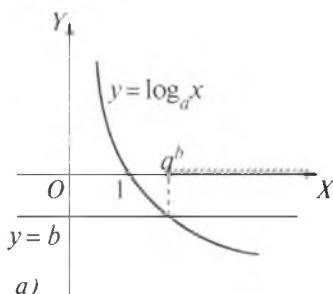

75- rasm.

$\log_x N = b$ ko'rinishdagi tenglamani qaraymiz. Bu tenglamaning aniqlanish sohasi x ning $x > 0$, $x \neq 1$ munosabatlarni qanoatlantiruvchi barcha qiymatlaridan tashkil topadi. Agar $N \leq 0$ bo'lsa, bu tenglama yechimga ega bo'lmaydi. $N > 0$ bo'lsa, $x = N^{\frac{1}{b}}$ dan iborat yagona yechimga ega bo'ladi.

$\log_a x < b$, $\log_a x > b$, $\log_a x \leq b$, $\log_a x \geq b$ ko'rinishdagi (bu yerda $a > 0$, $a \neq 1$) tengsizliklar eng sodda logarifmik tengsizliklardir. Ularni yechishda $y = \log_a x$ funksiyaning monotonligidan foydalaniladi.

$\log_a x < b$ logarifmik tengsizlikni qaraymiz. Agar $0 < a < 1$ bo'lsa, bu tengsizlikning barcha yechimlari to'plami $(a^b; +\infty)$ oraliqdan iborat bo'ladi (75- a rasm). Agar $a > 1$ bo'lsa, qaralayotgan tengsizlikning barcha yechimlari to'plami $(0; a^b)$ oraliqdan iborat bo'ladi (75- b rasm).

$\log_a x > b$, $\log_a x \leq b$, $\log_a x \geq b$ tengsizliklar ham shunga o'xshash yechiladi.

1- misol. a) $\log_3 x = 9$; b) $\log_3 64 = 2$ tenglamalarni yechamiz.

Yechish. a) Tenglamani potensirlaymiz. Natijada: $x = 3^9$;
b) tenglamani potensirlaymiz: $x^2 = 64$, bundan $x = 8$.

2- misol. a) $\log_3 x < 9$; b) $\log_{\frac{1}{3}} x < 9$ tengsizliklarni yechamiz.

Yechish. a) oldingi misolda $\log_3 x = 9$ tenglamaning $x = 3^9$ ildizi topilgan edi. Asos $a = 3 > 1$, $b = 9$.

Yechim: $(0; 3^9)$ yoki $0 < x < 3^9$;

b) $a = \frac{1}{3} \in (0; 1)$ bo'lgani uchun yechim $(3^{-9}; +\infty)$ oraliqdan iborat.

1- teorema. $\log_a f(x) = \log_a g(x)$ ($a > 0$, $a \neq 1$) tenglama

$$\begin{cases} f(x) = g(x), \\ f(x) > 0 \end{cases} \quad (1)$$

sistemaga teng kuchlidir.

Isbot. $y = \log_a t$ ($a > 0$, $a \neq 1$) logarifmik funksiya monoton. Shunga ko'ra $\log_a f(x) = \log_a g(x)$ tengligining bajarilishi uchun $f(x) = g(x)$ bo'lishi kerak. Demak, $f(x) > 0$ bo'lganda $\log_a f(x) = \log_a g(x)$ tenglama $f(x) = g(x)$ tenglamaga teng kuchli.

1'-teorema. **$\log_a f(x) = \log_a g(x)$ ($a > 0$, $a \neq 1$) tenglama**

$$\begin{cases} f(x) = g(x), \\ g(x) > 0 \end{cases}$$

sistemaga teng kuchlidir.

Bu teoremani isbotlashda 1- teoremaning isbotidagi kabi mulohazalar yuritiladi (1'- teoremani mustaqil isbotlang).

2-teorema. **Agar $0 < a < 1$ bo'lsa, $\log_a f(x) > \log_a g(x)$ tengsizlik $0 < f(x) < g(x)$ qo'sh tengsizlikka, $a > 1$ bo'lsa, $f(x) > g(x) > 0$ qo'sh tengsizlikka teng kuchlidir.**

Bu teoremaning isboti logarifmik funksiyaning monotonligidan kelib chiqadi.

3- misol. $\frac{\lg \sqrt{x+7} - \lg 2}{\lg 8 - \lg(x-5)} = -1$ tenglamani yechamiz.

Yechish. 1) Tenglamaning aniqlanish sohasini topamiz:

$$\begin{cases} x + 7 > 0, \\ x - 5 > 0, \\ \lg 8 - \lg(x - 5) \neq 0 \end{cases} \Rightarrow \begin{cases} x > -7, \\ x > 5, \\ x - 5 \neq 8 \end{cases} \Rightarrow \begin{cases} x > 5, \\ x > 13; \end{cases}$$

2) ifodani sodda ko'rinishga keltirish maqsadida ayniy almashtirishlarni bajaramiz:

$$\begin{aligned} \lg \sqrt{x+7} - \lg 2 &= \lg(x-5) - \lg 8 \Rightarrow \lg \frac{\sqrt{x+7}}{2} = \lg \frac{x-5}{8} \Rightarrow \\ \Rightarrow \frac{\sqrt{x+7}}{2} &= \frac{x-5}{8} \Rightarrow (\sqrt{x+7})^2 = \left(\frac{x-5}{4}\right)^2 \Rightarrow x^2 - 26x + 87 = 0. \end{aligned}$$

Bundan $x = 29$ ekani aniqlanadi.

4- misol. $\log_x \frac{3x+5}{x-3} < 0$ tengsizlikni yeching.

Yechish. Tengsizlikni $\log_x \frac{3x+5}{x-3} < \log_x 1$ ko'rinishda yozib olamiz va quyidagi hollarni qaraymiz:

1) $0 < x < 1$ bo'lsin. U holda $\frac{3x+5}{x-3} > 1$ tengsizlikka yoki $\frac{x+4}{x-3} > 0$ tengsizlikka ega bo'lamiz. Bu tengsizlik $(0; 1)$ oraliqda yechimga ega emas.

2) $x > 1$ bo'lsin. U holda $0 < \frac{3x+5}{x-3} < 1$ qo'sh tengsizlikka ega bo'lamiz. Bu qo'sh tengsizlik $x > 1$ shartni qanoatlantiruvchi yechimga ega emas. Shunday qilib, berilgan tengsizlik yechimga ega emas.

5 - misol. $\log_{\frac{x}{3}} x^2 - 18 \log_{81x} x^3 + 20 \log_{9x} \sqrt{x} = 0$ tenglamani yeching.

Y e c h i s h . Logarifmni boshqa asosga o'tkazish formulasidan foydalanib, barcha logarifmlarni 3 asosga o'tkazamiz:

$$\frac{2 \log_3 x}{\log_3 x - 1} - 18 \cdot \frac{3 \log_3 x}{4 + \log_3 x} + 20 \cdot \frac{\frac{1}{2} \log_3 x}{2 + \log_3 x} = 0.$$

Bu tenglamada $\log_3 x = t$ almashtirish bajaramiz va $\frac{t(7t^2 + 2t - 14)}{(t-1)(t+4)(t+2)} = 0$ tenglamaga ega bo'lamiz. Uni yechib, $t_1 = 0$, $t_2 = \frac{-1-3\sqrt{11}}{7}$, $t_3 = \frac{-1+3\sqrt{11}}{7}$ yechimlarni topamiz. $\log_3 x = t$ bog'lanish yordamida berilgan tenglamaning ildizlari topiladi:

$$x_1 = 0, \quad x_2 = 3^{\frac{-1-3\sqrt{11}}{7}}, \quad x_3 = 3^{\frac{-1+3\sqrt{11}}{7}}.$$



M a s h q l a r

8.44. Tenglamani yeching:

a) $2 \cdot \ln(x-3) = \ln x - \ln 4;$

b) $x^{\lg x} = x^{10};$

d) $0,1 \cdot x^{\lg x - 4} = 100^3;$

e) $4^{\frac{1}{\log_{16} x}} = \frac{1}{64};$

f) $x^{2 \log_a x} = ax, \quad a > 0;$

g) $\log_{25}(x^2 - 10x + 9) = 2;$

h) $\sqrt{\log_x \sqrt{3x}} \log_{\frac{1}{2}} x = 1;$

$$i) \log_{\frac{x}{a}} a^{-2} + \log_{a^2} x = a; \quad j) 2\log_x x^4 + \log_2 x = 4;$$

$$k) (1 + \log_c a) \log_a x \log_b c = \log_b x \log_a x \log_a c;$$

$$l) \log_4(2 \log_3(1 + \log_2(1 + 3 \log_3 x))) = \frac{1}{2};$$

$$m) \log_3(1 + \log_3(2^x - 7)) = 1; \quad n) \log_3(3^x - 8) = 2 - x;$$

$$o) \log_3(x + 1) + \log_3(x + 3) = 1;$$

$$p) 3^{\log_3 \lg \sqrt{x}} - \lg x + \lg^2 x - 3 = 0;$$

$$q) 9^{\log_3(1-2x)} = 5x^2 - 5; \quad r) x^{\log_3 x} = 9;$$

$$s) 3(\log_x \sqrt{5})^2 - 3 \log_x \sqrt{5} + 1 = 0;$$

$$t) \log_3(4 \cdot 3^x - 1) = 2x + 1;$$

$$u) 1 + 2\log_{(x+2)} 5 = \log_5(x + 2);$$

$$v) \lg(\lg x) + \lg(\lg x^3 - 2) = 0; \quad x) \lg_2 x = 6 - x;$$

$$y) \log_2 x = 3^{-x} + \frac{8}{9}; \quad z) \log_3(x + 5) = \log_{\frac{1}{2}} x + 4;$$

$$o') \log_2(3^x + 4) = 2 - 5^x; \quad g') x \log_2 x = 24.$$

8.45. Tengsizlikni yeching:

$$a) \lg^2 x^2 + 5 \lg x > -1,25;$$

$$b) \log_x(\sqrt{9 - x^2} - x - 1) \geq 1;$$

$$d) (\log_x 2)(\log_{2x} 2)(\log_2 4x) > 1;$$

$$e) \log_{\frac{49-x^2}{16}} \frac{46-4x-x^2}{14} > 1;$$

$$f) x^{(\lg x)^2 - 3 \lg x + 1} > 1000; \quad g) \log_x(24 - 2x - x^2) < 1;$$

$$h) \log_{x-1} 9 < \log_x 3; \quad i) \log_{\frac{1}{3}}((x+5)(x-6)) > 2;$$

$$j) (\log_{2x} 0,5)^2 \leq \log_{2x}(2x^2);$$

$$k) 2^x \log_3 x + \log_3 x \leq 2^{x+1} + 2;$$

$$l) \log_{\frac{1}{3}}(5x - 1) > 0;$$

$$m) \log_5(3x - 1) < 1;$$

$$n) \log_2 x \leq \frac{2}{\log_2 x - 1};$$

$$o) \log_{3x+5}(9x^2 + 8x + 8) > 2;$$

$$p) \log_{0,2}(x^2 - x - 2) > \log_{0,2}(-x^2 + 2x + 3);$$

$$q) \log_x(\log_9(3^x - 9)) < 1;$$

$$r) \log_{2x}(x^2 - 5x + 6) < 1;$$

$$s) \log_{x^2}(2 + x) < 1;$$

$$t) (0,5)^{\log_3 \log_{\frac{1}{5}}(x^2 - \frac{4}{5})} < 1;$$

$$u) \frac{1 - \log_4 x}{1 + \log_2 x} \leq \frac{1}{2}.$$

3. Ko'rsatkichli va logarifmik tenglamalar sistemalari. Bu tur sistemalarni yechishda oldingi bandlarda bayon qilingan algebraik qo'shish, o'rniga qo'yish, yangi o'zgaruvchi kiritish, ko'paytuvchilarga ajratish, grafik yechish usullaridan, shuningdek, funksiyalarning xossalariidan foydalaniladi.

$$1\text{-misol. } \begin{cases} \log_{\sqrt{3}} x + \log_3 y = \log_{\sqrt{3}} 3, \\ \log_3 x - \log_{\sqrt{3}} y = -\log_3 243 \end{cases} \quad (1)$$

ni yeching.

Yechish. Logarifmlarni bir asosga ($a = 3$ ga) keltirilib, potensirlashlar va soddalashtirishlar bajariladi:

$$\log_{\sqrt{3}} x = 2 \log_3 x; \quad \log_3 3 = 1; \quad \log_{\sqrt{3}} 3 = 5 \log_3 3;$$

$$\log_3 x = u; \quad \log_3 y = v.$$

$$(1) \Rightarrow \begin{cases} 2u + v = 5, \\ u - 2v = -5, \end{cases} \Rightarrow \begin{cases} y = 3^3 = 27, \\ x = 3. \end{cases}$$

2-misol.

$$\begin{cases} 2^{1+2\log_2(y-x)} = 32, \\ 2 \log_5(2y - x - 12) = \log_5(y - x) + \log_5(y + x) \end{cases} \quad (2)$$

ni yeching.

Yechish. Birinchi tenglamadan $(y-x)^2 = 16$ tenglamani va

bundan $y-x > 0$ ekanligini e'tiborga olib, $y-x=4$ ni olamiz. Sistema quyidagi ko'rinishga keladi:

$$\begin{cases} y - x = 4, \\ 2 \log_5 (2y - x - 12) = \log_5 (y - x) + \log_5 (y + x). \end{cases} \quad (2')$$

(2') sistemadagi 1- tenglamadan $y = 4 + x$ ni topib, 2- tenglamaga qo'ysak, faqat x noma'lum qatnashadigan tenglama hosil bo'ladi, uni yechib, x ni topamiz:

$$\begin{aligned} 2 \log_5 (x - 4) &= \log_5 4 \log_5 (4 + 2x) \Rightarrow \log_5 (x - 4)^2 = \\ &= \log_5 4(4 + 2x) \Rightarrow (x - 4)^2 = 4(4 + 2x) \Rightarrow x^2 - 16x = 0 \Rightarrow \\ &\Rightarrow \{x_1 = 0, x_2 = 16\}. \end{aligned}$$

Bu tenglamani faqat $x = 16$ soni qanoatlantiradi. $y = 4 + x$ dan $y = 20$ ekani kelib chiqadi.

J a v o b : (16; 20).

3- m i s o l . $\begin{cases} y - 2^x = 1, \\ \log_{\frac{1}{2}} x - y = 0 \end{cases}$ sistemani grafik usulda yeching.

Y e c h i s h . Koordinatalar sistemasida $y = 2^x + 1$ va $y = \log_{\frac{1}{2}} x$ funksiyalar grafiklarini yasaymiz (76- rasm).

Ikkala grafik taqriban $A(0,5; 2,2)$ nuqtada kesishadi.

J a v o b : $x \approx 0,5, y = 2,2$.

4- m i s o l . $n > 0, n \neq 1,$

$$\frac{\lg n}{10^{2m-1}} > 0 \text{ bo'lganda}$$

$$\begin{cases} \lg x - \lg y = m, \\ 10^{x^2 - y^2} = n \end{cases}$$

sistemani yeching.

Y e c h i s h . Logarifmik funktsiya ta'rifiga ko'ra $x > 0, y > 0$. Ikkinchi tenglamadan $(x^2 - y^2) \lg 10 = \lg n; x^2 - y^2 = \lg n$. Berilgan sistema

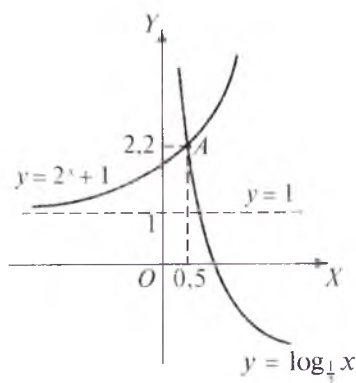

76- rasm.

$$\begin{cases} \frac{x}{y} = 10^m, \\ x^2 - y^2 = \lg n, \\ x > 0, y > 0 \end{cases} \text{ tenglama va tengsizliklar sistemasiga keladi.}$$

Bundan $x = 10^m y$, $10^{2m} y^2 - y^2 = \lg n$, $y^2 = \frac{\lg n}{10^{2m} - 1}$,
 $y = \sqrt{\frac{\lg n}{10^{2m} - 1}}$, $x = 10^m \sqrt{\frac{\lg n}{10^{2m} - 1}}$.



Mashqlar

Quyidagi tenglamalar sistemasini yeching (8.46–8.55):

$$8.46. \begin{cases} x + y = 6, \\ \log_2 x + \log_2 y = 3. \end{cases}$$

$$8.47. \begin{cases} x - y = 1, \\ 4^x + 2^y = 18. \end{cases}$$

$$8.48. \begin{cases} x^2 + y^2 = 68, \\ \log_2 x - \log_2 y = 2. \end{cases}$$

$$8.49. \begin{cases} 3^{x+y} = 9, \\ \log_2(x+1) + \log_2(y+1) = 2. \end{cases}$$

$$8.50. \begin{cases} \log_3(x-y) = 1, \\ 10 \cdot 25^y - 5^{x-1} = 125. \end{cases}$$

$$8.51. \begin{cases} \log_2 x + 2 \log_4 y = 3, \\ 3 \log_8(x+1) - \log_{\sqrt{2}}(y-1) = \log_{\frac{1}{2}} 3. \end{cases}$$

$$8.52. \begin{cases} \log_{x-2}(xy - x - 2y + 2) + \frac{1}{2} \log_{y-1}(x^2 - 4x + 4) = 3, \\ \log_{x+1}(y + x - 2) - \log_{y+2}(x^2 + y^2) = -1. \end{cases}$$

$$8.53. \begin{cases} \log_{x-2}(xy + x + y + 1) + \log_{x+y}(y + 2) = -4, \\ 2 \log_{x+1}(y + 1) - \log_{x+y}(y^2 + 2x + xy + 2y) = 2. \end{cases}$$

$$8.54. \begin{cases} x^y = y^{2x}, \\ x^3 = y^2, \end{cases} \quad (x > 0, y > 0).$$

$$8.55. \begin{cases} x^y = y^{4x}, \\ x^{-x} = y^y, \end{cases} \quad (x > 0, y > 0).$$

8.56. Tenglamalar sistemasini yeching:

$$a) \begin{cases} 5^{2x} - 2^y = 21, \\ 2 \log_4 x + \log_4 y = 2; \end{cases}$$

$$b) \begin{cases} 4^{3x} - 3^y = -26, \\ 4^x - 3^{\frac{y}{3}} = -2; \end{cases}$$

$$d) \begin{cases} \frac{1}{\lg u+1} = -2^{-v} + \frac{1}{\lg u-1}, \\ \lg^2 u = 2^v + 5; \end{cases}$$

$$e) \begin{cases} |\lg |x| + \lg |y|| = 1 + \lg 4, \\ |x|^{|y|} = 4. \end{cases}$$

8.57. Tenglamalar sistemasini yeching:

$$a) \begin{cases} 3^x \cdot 2^y = 9, \\ \log_{\sqrt{3}}(x - y) = 2; \end{cases}$$

$$b) \begin{cases} \log_{a^2} x + \log_a y = \frac{3}{2}, \\ \log_b x + \log_{b^2} y = 1; \end{cases}$$

$$d) \begin{cases} \log_3 x^2 + \log_3 y^2 = 2, \\ y - 5x = -2. \end{cases}$$

8.58. a va b parametrlarning qanday qiymatlarida

$$\begin{cases} a^x + a^y = 2^{-1}, \\ x + y = -\log_a 16 \end{cases} \quad \text{sistema yechimga ega bo'ladi?}$$

8.59. Tenglamalar sistemasini yeching:

$$\begin{cases} \log_{0.3} x^3 + \log_{0.3} y^2 = -2, \\ x - 3y = 0,1. \end{cases}$$

8.60. Agar $3^{y+5} = 9^x$ va $x + y = 1$ bo'lsa, $x - y$ ni toping.

8.61. Taxta, bo'yoq va sement xarid qilindi. Agar 1 m^3 taxta sotuvdagi narxidan to'rt marta arzon, 1 quti bo'yoq ikki marta qimmat, 1 t sement uch marta arzon bo'lganda qilingan xarid 750 so'm turgan bo'lardi. Agar taxta besh

marta arzon, boyoq to'rt marta arzon, sement ikki marta arzon bo'lganda xarid uchun 400 so'm to'langan bo'lardi. Necha so'mlik xarid qilingan?

- 8.62.** Jami 228 so'mga 3, 5, 7 so'mlik uch xil qalam keltirilgan. 7 so'mliklari 3 so'mliklaridan 6 dona kam, 3 so'mliklari 5 so'mliklaridan 2,2 marta ko'p, 3 so'mlik va 5 so'mliklarining umumiy soni 7 so'mliklari sonidan ikki marta ortiq. Har qaysi qalamdan qanchadan keltrilgan?



Takrorlashga doir mashqlar

- 8.63.** Ko'rsatkichli funksiyaning xossalariidan foydalanib, sonlarni taqqoslang:

a) $\left(\frac{5}{7}\right)^{0,8}$ va 1;

b) $\left(\frac{2}{3}\right)^{\frac{1}{2}}$ va 1;

d) $\left(\frac{4}{5}\right)^3$ va $\left(\frac{4}{5}\right)^5$;

e) $(0,4)^{-2}$ va $(0,4)^3$;

f) $(2,56)^0$ va $(0,312)^0$;

g) $(1,7)^{-3}$ va $(1,7)^{-2}$;

h) $\left(\frac{1}{3}\right)^{2,7}$ va $\left(\frac{1}{3}\right)^{5,2}$;

i) $\left(\frac{8}{5}\right)^{-3}$ va $\left(\frac{8}{5}\right)^{\frac{1}{2}}$;

j) $(0,2)^{-6,5}$ va $5^{5,6}$;

k) $3^{-1,2}$ va $\left(\frac{1}{3}\right)^{2,8}$;

l) $\operatorname{tg}\left(\frac{\pi}{3}\right)^{-1}$ va 1;

m) $(\sqrt{3})^{-2}$ va $\left(\frac{1}{3}\right)^2$.

- 8.64.** Agar:

a) $a^{-\frac{2}{3}} > a^{\frac{5}{3}}$; b) $a^{\frac{7}{8}} > a^{\frac{11}{8}}$; d) $a^{\frac{3}{5}} > a^{0,6}$; e) $a^{-\frac{1}{3}} > a^{0,2}$

bo'lsa, a o'zgaruvchi qanday qiymatlarni qabul qilishi mumkinligini aniqlang.

- 8.65.** Agar:

a) $1,34\alpha < 1,34\beta$; b) $\sqrt{0,364^\alpha} < \sqrt{0,364^\beta}$;

d) $\sqrt[20]{1,6^\alpha} < \sqrt[20]{1,6^\beta}$ bo'lsa, α va β larni taqqoslang.

8.66. $\alpha^{0,4} < \alpha^{0,5}$ bo'lsa, 1 va α sonlarini taqqoslang.

8.67. a) $\pi^{1,5}$ va $3,14^{1,5}$; b) $2,71828\dots^{-0,8}$ va $2,72^{-0,8}$ sonlarini taqqoslang.

8.68. x o'zgaruvchi -5 dan 0 gacha o'zgarsa, $y = \left(\frac{1}{5}\right)^x$ funksiya qanday o'zgaradi?

8.69. Funksiyaning aniqlanish sohasini toping:

a) $y = 16^{\frac{1}{9-x}}$;

b) $f(x) = \left(\frac{1}{18}\right)^{\sqrt{x^2-9}}$;

d) $g(x) = \frac{19}{14^{x^4}}$;

e) $\varphi(x) = \frac{1}{2^{x^2-4}}$.

8.70. Funksiyaning qiymatlar sohasini toping:

a) $y = 3^{|x|}$;

b) $y = -9^x$;

d) $y = |13^x - 13|$;

e) $y = \frac{1}{|4^{x^2} + 1|}$.

8.71. Logarifmik funksiyaning xossaligidan foydalanib, sonlarni taqqoslang:

a) $\log_4 5$ va $\log_4 9$;

b) $\log_{\frac{1}{5}} 8$ va $\log_{\frac{1}{5}} 15$;

d) $\log_9 7$ va $\log_8 7$;

e) $\log_{\frac{1}{3}} 7$ va $\log_{\frac{1}{9}} 7$.

8.72. Ifodaning ishorasini aniqlang:

a) $\log_{0,8} 4 - \log_{\frac{1}{2}} 5$;

b) $\log_3 10 - 2$;

d) $\log_{0,2} 18 - \log_{0,2} 17$;

e) $\log_4 8 - 1$.

8.73. Funksiyaning aniqlanish sohasini toping:

a) $y = \log_3(3x + 10)$;

b) $y = \log_{30}(-12x)$;

d) $y = \log_5 x^2$;

e) $y = \log_3(x^2 - \sqrt{3})$;

f) $y = \log_{11}(9 - x^2)$;

g) $y = \log_{13}(13x^2 + 11)$;

h) $y = \log_4 \sqrt{9x^2 - 16}$;

i) $y = \log_5 |x^2 - 3x + 10|$.

8.74. Agar barcha $x > 0$ sonlar uchun

a) $\log_a(x^2 + 3) > \log_a x$;

b) $\log_a(x^2 + 3) < \log_a x$

bo'lsa, a qanday qiymatlar qabul qilishi mumkin?

8.75. Hisoblang:

a) $15^{1+\log_{15} 2}$;

b) $4^{2+\log_4 9}$;

d) $17^{3\log_{17} 2}$;

e) $8^{1-\log_2 3}$;

f) $\log_{\sqrt{5}} \sqrt{625}$;

g) $\log_2 0,125 + \log_{\sqrt{3}} 9$;

h) $\log_{3\sqrt{7}} \sqrt{49}$;

i) $\log_2 \log_2 \sqrt{\sqrt{2}}$.

8.76. $\log_4 125 = a$ bo'lsa, $\lg 64$ ni toping.

8.77. Ifodani soddalashtiring: $a^{\frac{\lg(\lg a)}{\lg a}} + \lg b^2 + \log_{100} a$.

8.78. Agar $y = 10^{\frac{1}{1-\lg x}}$ va $z = 10^{\frac{1}{1-\lg y}}$ bo'lsa, $x = 10^{\frac{1}{1-\lg z}}$ bo'lishini isbotlang.

Tenglamani yeching (8.79–8.102):

8.79. $(2(2^{\sqrt{x}+3})^{\frac{1}{2\sqrt{x}}})^{\frac{2}{\sqrt{x}-1}} = 4$. 8.80. $\sqrt{2^{x^2-2x-10}} = \sqrt{33} + \sqrt{128} - 1$.

8.81. $x - \sqrt{5^{x+3}} x^2 - \sqrt{5^{2(x-1)}} = x + \sqrt{25^{x+4}}$.

8.82. $3^x + \sqrt{3^{x+2}} \cdot 7^x = 3 \cdot 7^x + \sqrt{21^x}$.

8.83. $8(4^x + 4^{-x}) - 54(2^x + 2^{-x}) + 101 = 0$.

8.84. $0,5 \lg(x+3) - 2 \lg 2 = 1 - \lg \sqrt{25x+375}$.

8.85. $\lg^2(100^x) + \lg 2(10x) + \lg^2 x = 14$.

8.86. $\log_{2x^2-2}(3x^2 + x - 4) = \log_8 16 - \log_{27} 3$.

8.87. $\log_3(3^x = 8) = 2 - x$.

8.88. $2x + 1 = 2 \log_2(9^x + 3^{2x-1} - 2^{x+3,5})$.

8.89. $x(1 - \lg 5) = \lg(2^x + x - 1)$.

8.90. $2(\lg 2 - 1) + \lg(5^{\sqrt{x}} + 1) = \lg(5^{1-\sqrt{x}} + 5)$.

8.91. $\log_3(3^x - 1) \cdot \log_3(3^{x+1} - 3) = 6$.

8.92. $x + \lg(1 + 2^x) = x \lg 5 + \lg 6$.

8.93. $\log_6(2^{\sqrt{x+1}} - 3) = \log_6 \log_{\sqrt{3}} 9^{\frac{1}{3}} - \frac{\sqrt{x}}{2} \log_6 4$.

8.94. $7^{\lg x} - 5^{\lg x + 1} = 3 \cdot 5^{\lg x - 1} - 13 \cdot 7^{\lg x - 1}$.

$$8.95. \log_{2-2x^2}(2-x^2-x^4) = 2 - \frac{1}{\log_3(2-2x^2)}.$$

$$8.96. x^2 \log_6 \sqrt{5x^2 - 2x - 3} - x \log_{\frac{1}{6}}(5x^2 - 2x - 3) = x^2 - 2x.$$

$$8.97. \log_3 2 + \log_3 \log_3(4-x) = \log_3 \log_3(19-6x).$$

$$8.98. \sqrt{2 \log_8(-x)} - \log_8 \sqrt{x^2} = 0.$$

$$8.99. \log_{3x+7}(9+12x+4x^2) + \log_{2x+3}(6x^2+23x+21) = 4.$$

$$8.100. \log_{1-2x}(6x^2-5x+1) + \log_{1-3x}(4x^2-4x+1) = 2.$$

$$8.101. \log_{x+1}(1-3x) = \log_{\sqrt{1-3x}}(1-2x-3x^2) - 1.$$

$$8.102. \sqrt{4-x} \cdot 4^{\log_2 x} + \log_3(x-2) = 9, \quad x - \text{butun son.}$$

Tengsizlikni yeching (8.103–8.110):

$$8.103. \frac{1}{4} \cdot \left(\frac{1}{8}\right)^{x-2} < 3\left(\frac{1}{2}\right)^{x-1} + 2^x. \quad 8.104. |3^x - 2| \leq 1.$$

$$8.105. 2^{|x+2|} > 16. \quad 8.106. (\sqrt{5}+2)^{x-1} \geq (\sqrt{5}-2)^{\frac{x-1}{x}}.$$

$$8.107. \log_3 \sqrt{x^2 + x - 2} < 1. \quad 8.108. \sqrt{\log_2 \left(\frac{3x-1}{2-x}\right)} < 1.$$

$$8.109. \left(\frac{1}{2}\right)^{\log_3 \log_{\frac{1}{5}}\left(x^2 - \frac{4}{5}\right)} > 1.$$

$$8.110. (3^{x+3} + 3^{-x})^{3 \lg x - \lg(2x^2+3x)} < 1.$$

Tenglamalar sistemasini yeching (8.111–8.114):

$$8.111. \begin{cases} y^2 = 4^x + 8, \\ 2^{x+1} + y + 1 = 0. \end{cases} \quad 8.112. \begin{cases} 3^x \cdot 5^y = 75, \\ 3^y \cdot 5^x = 45. \end{cases}$$

$$8.113. \begin{cases} \lg^2 x = \lg^2 y + \lg^2(x \cdot y), \\ \lg^2(x-y) + \lg x \cdot \lg y = 0. \end{cases} \quad 8.114. \begin{cases} \log_5 x + 3^{\log_3 y} = 7, \\ x^y = 5^{12}. \end{cases}$$

8.115. Tengsizliklar sistemasini yeching:

$$\begin{cases} x + 2,25y - \sqrt{x} - 1,5\sqrt{y} + 0,5 \leq 0, \\ \sqrt{\log_x y} + \sqrt{\log_y x} \geq 2. \end{cases}$$

JAVOBLAR

I bob

- 1.1.** $\{1, 9, 2\}$. **1.2.** $10 \in B, 136 \in B$. **1.3.** $S = \{-3; -2; -1; 4\}, S_1 = \{3; 2; 1; -4\}$. **1.4.** $\{B, O', Sh, V, A, Q, T, D, N, U, M, I, L, F, O, Y\}$. **1.5.** a) $\{1; 2; 3; 4\}$; b) $\left(-\frac{7}{4}\right)$; d) $\{0; 12\}$; e) $(-\sqrt{2}; \sqrt{2})$; f) $\{1; 2\}$; g) $\{1; 2; 3\}$. **1.6.** (77- rasm). **1.7.** a) $\{111, 113, 131, 133, 311, 313, 331, 333\}$; b) $\{135, 153, 315, 351, 513, 531\}$; d) $\{104, 140, 203, 302, 320, 401, 410, 500\}$; e) $\{1, 11, 21, 31, 41, 51, 61, 71, 81, 91\}$. **1.8.** a), b). **1.10.** f). **1.14.** a) $E \subset A$; b) $D \subset C$. **1.15.** $\{3\}; \{6\}; \{9\}; \{12\}; \{3; 6\}; \{3; 9\}; \{3; 12\}; \{6; 9\}; \{6; 12\}; \{9; 12\}; \{3; 6; 9\}; \{3; 6; 12\}; \{3; 9; 12\}; \{6; 9; 12\}; \emptyset; A$. **1.16.** a) $A \subset B$; b) $C \subset D$; d) $E \subset F$; e) $K \not\subset M; M \not\subset K$.

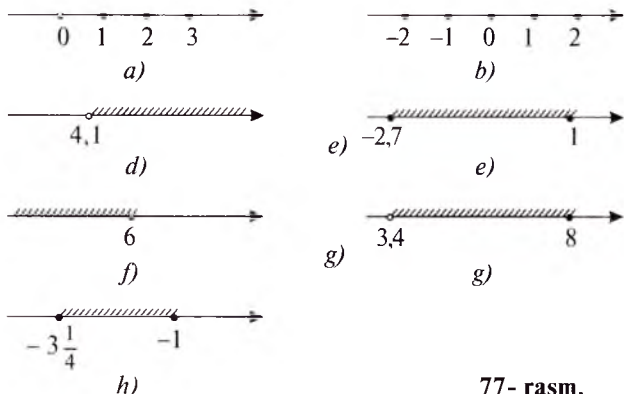

77- rasm.

- 1.17.** a) $B \subset A$; b) $A \subset B$; d) $A \subset B; B \subset A$; e) $A \subset B$; f) $A \subset B$; g) $B \subset A$; h) $B \subset A$. **1.18.** a) to'g'ri; b) noto'g'ri; d) noto'g'ri; e) noto'g'ri. **1.19.** a) $A = B$; b) $A \neq B$; d) $A \neq B$; e) $A = B$. **1.25.** $[3; 5]$. **1.26.** $P \cup E = \{a, b, c, d, e, f, g, z, k\}$. **1.28.** a) $A \cup B = \{x | x = 4k, k \in \mathbb{Z}\}$. **1.31.** $A \setminus B = \{x | x \in \{-5; 3\} \cup (3; 4) \cup (4; 5) \cup (5; 6) \cup (6; 7) \cup (7; 8) \cup (8; 9) \cup (9; 10)\}$. **1.35.** $A = \{x | x = 2k, k \in \mathbb{Z}\}$. **1.44.** 20 kishi. **1.45.** 13 kishi. **1.47.** 68 kishi. **1.48.** 4 ta.

II bob

- 2.2.** Hammasiga. **2.3.** $k = 2431$ bo'lishi mumkin, $k \notin \{15; 18\}$. **2.4.** $k = 1, 3, 5, 7, 15, 21, 35, 105$. **2.23.** a) 2; b) 5555; d) 20; e) 1; f) 1; g) 600. **2.27.** 1. **2.29.** $\{7; 14; 21\}$. **2.30.** $\{117342; 1897524\}$. **2.49.** a) $\frac{5}{6}$; b) 1; d) 9. **2.50.** a) Faraz: $\sqrt{3}$ - ratsional son, $\sqrt{3} = \frac{m}{n} > 0$, bunda $m, n \in \mathbb{N}$ va $B(m; n) = 1$. U holda $3n^2 = m^2$, bundan m^2 ning, demak, m ning ham 3 ga bo'linishi ma'lum bo'ladi; $m = 3k$; $3n^2 = 9k^2$; n^2 ham, demak, n ham 3 ga bo'linadi. $\frac{m}{n}$ kasr 3 ga qisqarmoqda. Bu esa shartga zid, demak, $\sqrt{3}$ soni ratsional son emas. **2.51.** Ratsional son mav-

jud va u $r = \frac{m}{n}$, $B(m; n) = 1$ deb faraz qilinsa, $5^{\frac{m}{n}}$ bo'ladi. U holda $5^m = 2^n$ va hokazo. **2.55.** a); e); f); h). **2.57.** Ajratuvchi sonlar: a) $2\pi R$; d) 3. **2.68.** a) $a = b$ yoki $a = -b$; d) $b \in (-\infty; 0]$. **2.74.** $|a| + |b| + |c| + |d| \neq 0$. **2.75.** $|a - b| + |b - c| + |a - c| \neq 0$. **2.76.** $|a - b| + |b - c| + |a - c| \leq 0$. **2.77.** h) 3; i) -4; j) 3; k) 14. **2.79.**

a) $x \in \left[7; 8\frac{1}{3}\right]$; d) $x \in \{-4,5; -4\}$. **2.80.** $\{-2; -1\}$. a) Ko'rsatma: $0 \leq \frac{x-1}{2} - x < 1$ ning butun yechimlarini toping; e) \emptyset . **2.81.** Agar $p = n$

bo'lsa, $\left[\frac{n}{p}\right] = 1$. Agar $p < n$ bo'lsa, $1 \cdot p, 2 \cdot p, \dots, \left[\frac{n}{p}\right] \cdot p$ sonlarigina p ga bo'linadi. $\left(\left[\frac{n}{p}\right] + 1\right) \cdot p$ soni esa n dan katta. Demak, $\left[\frac{n}{p}\right]$ ta had p ga bo'linadi.

Agar $p > n$ bo'lsa, $\left[\frac{n}{p}\right] = 0$. **2.82.** Nollar soni 2 va 5 tub sonlardan tuzilgan juftlar soniga teng. **2.83.** $600! = 1 \cdot 2 \cdot 3 \cdot \dots \cdot 600$ yoyilmada 2 tub sonning 600! soni

bo'linadigan eng katta darajasi $\left[\frac{600}{2}\right] + \left[\frac{600}{2^2}\right] + \left[\frac{600}{2^3}\right] + \left[\frac{600}{2^4}\right] + \left[\frac{600}{2^5}\right] + \left[\frac{600}{2^6}\right] + \left[\frac{600}{2^7}\right] + \left[\frac{600}{2^8}\right] + \left[\frac{600}{2^9}\right] = 300 + 150 + 75 + 37 + 18 + 9 + 4 + 2 + 1 + 0 = 594$. Javob:

594. Shu kabi 7 tub sonning eng katta darajasi $\left[\frac{600}{7}\right] + \left[\frac{600}{7^2}\right] + \left[\frac{600}{7^3}\right] + \left[\frac{600}{7^4}\right] = 85 + 12 + 1 + 0 = 98$. Javob: 98. 5 soni uchun $\left[\frac{600}{5}\right] + \left[\frac{600}{5^2}\right] + \left[\frac{600}{5^3}\right] =$

$= 120 + 24 + 4 = 148$. Javob: 148. **2.84.** $n! = 1 \cdot 2 \cdot \dots \cdot n$ natural sonlar yoyilmasida p

tub songa bo'linuvchilar soni $\left[\frac{n}{p}\right]$ ta, p^2 ga bo'linuvchilar soni $\left[\frac{n}{p^2}\right]$ ta, p^3 ga bo'linuvchilar soni $\left[\frac{n}{p^3}\right]$ ta va hokazo. $n!$ yoyilmada p tub son va uning

darajalariga bo'linuvchilarning umumiy soni $\left[\frac{n}{p}\right] + \left[\frac{n}{p^2}\right] + \dots + \left[\frac{n}{p^m}\right]$, bunda $p^m <$

$< n < p^{m+1}$. **2.89.** a) 1; b) $\frac{1}{3}$; d) 5. **2.92.** a) 25%; b) 60%; d) 250%. **2.95.** 1,75 kg.

2.97. 240 ta. **2.102.** 9 m va 10,8 m. **2.103.** 8,8 m va 11 m. **2.105.** 2 yildan keyin.

2.106. a) $70 = 23 \cdot 3 + 1$; b) $180 = 20 \cdot 9$; d) $200 = 11 \cdot 17 + 13$; e) $76 = 8 \cdot 9 + 4$.

2.107. a) $5 = 0 \cdot 9 + 5$; d) $9 = 0 \cdot 18 + 9$. **2.109.** $q_1 = -q - 1$; $r_1 = b - r$. **2.113.**

a) $n = 3$, $n = 5$; b) $n = 3$; d) hech bir qiymatida; e) $n = 3$, $n = 9$; f) $n = 3$, $n = 5$, $n = 9$; g) hech bir qiymatida; h) $n = 3$, $n = 9$; i) $n = 3$, $n = 5$.

III bob

3.1. a) $\operatorname{Re}(z) = -5$, $\operatorname{Im}(z) = 8$; j) $\operatorname{Re}(z) = 0$, $\operatorname{Im}(z) = 8$; l) $\operatorname{Re}(z) = 4$, $\operatorname{Im}(z) = 0$.

3.2. a) $-4 + 8i$; d) 1,2. **3.5.** a) $\bar{z} = -3 - 5i$; d) $\bar{z} = -3 + 5i$; e) $\bar{z} = 3 - 5i$; f)

$\bar{z} = 3i$; g) $\bar{z} = 4.2$. **3.6.** a) $1 + i$; b) 8; d) 0; i) $6 - 9i$; j) $4 + 2i$. **3.7.** a) $1 + \frac{2}{3}i$;

b) $1 + i$; d) $1 + 3\frac{1}{9}i$; e) $4 + 13i$. **3.8.** a) $-13 + 11i$; f) $3\frac{5}{9}i$; g) $\frac{-1-\sqrt{2}}{2} + \frac{-1-\sqrt{2}}{2}i$;

h) $\frac{67+5\sqrt{2}}{15} + i$. **3.9.** a) $-9 + 19i$; h) 13. **3.10.** b) $2 - 0,6i$; j) $12 + 3i$;

k) $\frac{4}{51} - \frac{1}{51}i$. **3.11.** a) $a^2 + 4b^2 = (a - 2bi)(a + 2bi)$; k) $a^{2n} + b^{2k} = (a^n - ib^k)(a^n +$

$+ib^k)$. **3.12.** $i^n = \begin{cases} i, \text{ agar } n=4k+1, k=0, 1, 2, \dots \\ -1, \text{ agar } n=4k+2, k=0, 1, 2, \dots \\ -i, \text{ agar } n=4k+3, k=0, 1, 2, \dots \\ 1, \text{ agar } n=4k, k=0, 1, 2, \dots \end{cases}$ **3.13.** a) $13 + 21i$; d) $12i$; l) $8i$.

3.14. a) $12,5 - 12,5i$; f) $-3 + 1,8i$; m) i . **3.20.** $-\frac{1}{2} \pm \frac{\sqrt{3}}{2}i$. **3.21.** (78- rasm). **3.22.**

(79- rasm). **3.23.** a) $|z| = 5$; f) $|z| = 3\sqrt{2}$; j) $|z| = 1$; n) $|z| = 4$; o) $|z| = |b|$;

p) $|z| = 1$. **3.24.** a) $\frac{\pi}{4}$; b) $\frac{\pi}{3}$; d) $\frac{\pi}{2}$; e) 0; f) $\frac{\pi}{6}$; g) $\frac{3\pi}{2}$; h) $\frac{3\pi}{4}$; i) $\frac{5\pi}{6}$; j) 0;

k) $\frac{\pi}{2}$; l) π ; m) $\frac{3\pi}{2}$. **3.25.** a) $\sqrt{2}\left(\cos\frac{5\pi}{4} + i\sin\frac{5\pi}{4}\right)$; b) $\sqrt{2}\left(\cos\frac{7\pi}{4} + i\sin\frac{7\pi}{4}\right)$;

d) $2\left(\cos\frac{\pi}{6} + i\sin\frac{\pi}{6}\right)$; e) $2\left(\cos\frac{2\pi}{3} + i\sin\frac{2\pi}{3}\right)$; f) $2(\cos\pi + i\sin\pi)$;

g) $\cos\frac{\pi}{2} + i\sin\frac{\pi}{2}$; h) $\cos 0 + i\sin 0$; i) $\cos\pi + i\sin\pi$; j) $\sqrt{2}\left(\cos\frac{\pi}{4} + i\sin\frac{\pi}{4}\right)$;

k) $\cos\frac{2\pi}{3} + i\sin\frac{2\pi}{3}$; l) $\sqrt{11}\left(\cos\frac{\pi}{6} + i\sin\frac{\pi}{6}\right)$; m) $\cos\frac{5\pi}{6} + i\sin\frac{5\pi}{6}$;

n) $2\left(\cos\frac{\pi}{2} + i\sin\frac{\pi}{2}\right)$. **3.26.** $-3 - 4i = 5(\cos\left(\pi + \arctg\frac{4}{3}\right) +$

$+i\sin\left(\pi + \arctg\frac{4}{3}\right))$. **3.27.** $z = 2\left(\cos\frac{7\pi}{4} + i\sin\frac{7\pi}{4}\right)$. **3.28.** $z = \cos\frac{16\pi}{7} + i\sin\frac{16\pi}{7}$.

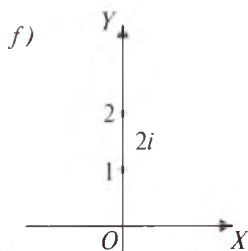
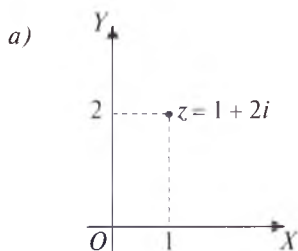

78- rasm.

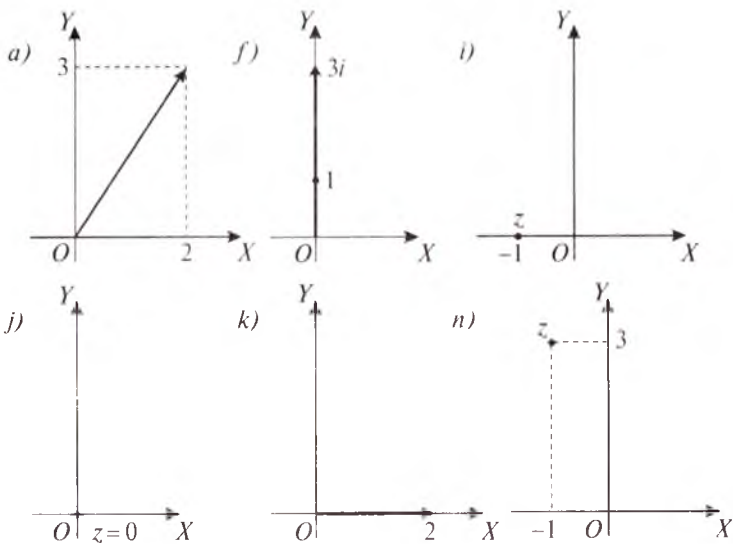

79- rasm.

3.34. $2(|u|^2 + |v|^2)$. **3.35.** Ko'rsatma: a) $|z - (0 + 10i)| \leq 20$, $w = 0 + 10i = (0; 10)$. Javob: markazi $(0; 10)$ nuqtada joylashgan va radiusi $R = 20$ bo'lgan aylana bilan chegaralangan doira; b) $\text{Re}(z) = \text{Re}(x + yi) = x > 4$. Koordinata tekisligining barcha shunday nuqtalari to'plamiki, ular $x = 4$ to'g'ri chiziqdan o'ngda joylashgan bo'ladi; g) yechilishi: $z = x + yi$, $\text{Re } z = x$. U holda $\sqrt{x^2 + y^2} = x + 3$, yoki $x^2 + y^2 = x^2 + 6x + 9$, yoki $y^2 = 6x + 9$. Bu parabola, uchi $z = -1.5 + 0 \cdot i = -1.5$, o'qi parabola uchidan o'ng tomonda yotgan haqiqiy o'qning

bir qismidan iborat. **3.36.** a) $\frac{\sqrt{2}}{2} \left(\cos \frac{3\pi}{8} + i \sin \frac{3\pi}{8} \right)$; b) $3\sqrt{3} \left(\cos \frac{\pi}{8} + i \sin \frac{\pi}{8} \right)$. **3.37.**

a) $\frac{\sqrt{3}}{2} \left(\cos \frac{2\pi}{399} + i \sin \frac{2\pi}{399} \right)$; e) $\cos \frac{2\pi}{3} + i \sin \frac{2\pi}{3}$. **3.43.** a) $Z_0 = \frac{\sqrt[4]{8}}{2} \left(\cos \frac{\pi}{8} + i \sin \frac{\pi}{8} \right)$,

$Z_1 = \frac{\sqrt[4]{8}}{2} \left(-\cos \frac{\pi}{8} - i \sin \frac{\pi}{8} \right)$; d) $Z_0 = \frac{\sqrt{3}}{2} + \frac{1}{2}i$, $Z_1 = -\frac{\sqrt{3}}{2} - \frac{1}{2}i$. **3.45.** $x = \sqrt[5]{r} \times$

$\left(\cos \frac{\varphi + 2k\pi}{5} + i \sin \frac{\varphi + 2k\pi}{5} \right)$ ga $k = 0, 1, 2, 3, 4$ larni qo'yib, x_1, x_2, \dots, x_5 larni

hisoblaymiz va $x_1 \cdot x_2 \cdot x_3 \cdot x_4 \cdot x_5 = r (\cos \varphi + i \sin \varphi)$ ni topamiz. **3.51.** a) $x \in \mathbb{R}$;

b) $x \in \emptyset$; d) 1; e) 2. **3.52.** $x = -\frac{2}{3}$; $y = -\frac{28}{9}$. **3.53.** a) -2^{10} ; b) $-2^{10}(1 - i)$.

3.58. a) $x_{1,2} = \frac{b \pm \sqrt{4ac - b^2}}{2a}$; b) $Z_1 = \frac{1}{2} + \frac{\sqrt{3}}{2}i$, $Z_2 = -\frac{1}{2} - \frac{\sqrt{3}}{2}i$, $Z_3 = \frac{1}{2} - \frac{\sqrt{3}}{2}i$,

$Z_4 = -\frac{1}{2} + \frac{\sqrt{3}}{2}i$.

IV bob

4.2. b) $59\frac{3}{7}$; d) $\frac{7}{416}$. 4.3. e) 0; l) 45; m) 222. 4.5. a) $27x^6y^3z^3$; g) $243x^5z^{20}$. 4.6.

e) $\frac{1}{27}$; h) $\frac{11}{13}$; i) $1\frac{3}{14}$. 4.8. a) $a^3 + x^2$; d) $5a - 12x$; i) $2x^3y + 32xz^2$. 4.12. b) $\frac{1}{2}$;

e) 3; h) 192. 4.15. $a + b + c = 0 \Rightarrow c = -a - b \Rightarrow a^3 + b^3 + c^3 = a^3 + b^3 - (a + b)^3 =$

$$= -3a^2b - 3ab^2 = 3ab(-a - b) = 3abc. \quad 4.17. |a+b| = \begin{cases} |a|, & a \neq 0, b = 0 \text{ bo'lsa,} \\ |b|, & a = 0, b \neq 0 \text{ bo'lsa,} \\ 0, & a = b = 0 \text{ bo'lsa.} \end{cases} \quad 4.22.$$

a) $3^{1999} + 147$; e) 17. 4.23. b) $a = -7$; e) $a = -17$. 4.24. a) 16; e) 84. 4.25. b) $a = 1$,

$\forall b \in C$; e) $a = 0, b = 4$. 4.26. $a = 3, b = -7, c = 4$. 4.28. a) 12; d) 14. 4.30.

a) $f(x)g(x) = 20x^5 + 16x^3 + 4x^2 + 8x$; e) $f(x)g(x) = 26x^5 + 73x^4 + 100x^3 + 33x^2 +$

12. 4.35. d) A, B, C lardan hech bo'lmasa birortasi 0 ga teng bo'lmasligi

kerak, aks holda berilgan ko'phad 2-darajali bo'lmay qoladi. $A \neq 0$ bo'lsin.

Ko'phadni $P(x; y) = Ax^2 + 2(By + D)x + (Cy^2 + 2Ey + F)$ ko'rinishda yozaylik.

Uni ikkita chiziqli haqiqiy ko'paytuvchiga ajratish uchun $P(x) = 0$ tenglama

ildizlarini bilish kerak:

$$x_{1,2} = \frac{-(By+D) \pm \sqrt{(By+D)^2 - A(Cy^2 + Ey + F)}}{A} = \frac{-(By+D) \pm \sqrt{(B^2 - AC)y^2 + 2(BD - AE)y + (D^2 - AF)}}{A}.$$

Bu ifoda noldan farqli aniq kvadrat bo'lgandagina izlanayotgan ko'paytma

hosil bo'ladi. Buning uchun ushbu shartlar bajarilishi kerak: 1) $B^2 - AC > 0$;

2) $(BD - AE)^2 - (B^2 - AC)(D^2 - AF) = 0$. Qolgan hollarda ham ko'rsatilganlar

kabi shartlar bajarilishi zarur va yetarli. 4.39. a) $a^8 + a^4 + 1$; b) $8xz$. 4.41.

a) $P(x) = D(x)(x + 1) + 2$; b) $P(x) = D(x)(x^2 + 4x + 1) + 2$; d) $P(x) = D(x)(x^2 +$

$+2x + 2) + 3x + 4$; e) $P(x) = D(x)(x^2 + 3x + 1) + 3x + 4$; f) $P(x) = D(x)(3x^2 + 5x -$

$-8) - 5x^2 + 14x + 2$; k) $P(x) = D(x)(x^2 + 3x + 5)$; l) $P(x) = D(x)(x^3 + 4x)$. 4.42.

a) $x + 1$; b) $x^2 + 1$; d) $x^3 + 1$; e) $x^2 - 2x + 2$; f) $x^3 - x + 1$; g) $x + 3$; h) $x^2 + x +$

$+ 1$; i) 1. 4.43. $a = 4, b = 0$.

V bob

5.1. a) $4x$; b) 36; d) $4a^4b^2c^4$; e) $\frac{8}{3}x^2y^5z$. 5.3. a) $\{2\}$; b) \emptyset ; d) $\{1; 2\}$; e) $\{-3;$

$3\}$; f) $\left\{-\frac{3}{2}\right\}$; g) \emptyset ; h) $\{4,5\}$; i) $\{13\}$; j) $\{0; -2\}$; k) $\{-a; a\}$; l) $\{-4; 4\}$; m)

$\{0; 5\}$; n) \emptyset ; o) $\{0; 3\}$; p) $\{-5; 9\}$; q) $\{1\}$. 5.4. a) $\{x | x \neq -2\}$; b) R ; d) $\{x | x \neq$

$\neq R \quad x \neq \pm 3\}$; i) $\{a | a \in R, a \neq 1, a \neq 2, a \neq 3\}$; k) $\{x | x \in R, x \neq \pm 4\}$;

l) $\{x | x \in R, x \neq 1, x \neq 7\}$; n) R ; p) R . 5.5. a) $\{(x; y) | x \in R, y \in R, x \neq 0, x \neq y\}$;

b) $\{(x; y) | x \in R, y \in R, |x| \neq |y|\}$; d) $\{(x; y) | x \in R, y \in R, y \neq x^2\}$; e) $\{(x; y) | x \in R,$

$y \in \mathbb{R}, x \neq 2, x \neq 3, y \neq 0$; g) $\{(x; y) \mid x \in \mathbb{R}, y \in \mathbb{R}, x \neq 0, y \neq 3x\}$; h) $\{(x; y) \mid x \in \mathbb{R}, y \in \mathbb{R}, x \neq \pm y\}$; l) $\{(x; y) \mid x \in \mathbb{R}, y \in \mathbb{R}\}$. **5.6.** a) $-\frac{a}{2}$; d) $\frac{x-2m}{x+2m}$; e) $\frac{2a+5}{a+2b}$; k) $\frac{1}{x+5}$; l) 1; m) x^2 . **5.7.** $\{3x^2+y; 3x^2 + \frac{1}{2}; 4a^2-x(a-3x); \frac{x^3}{4}; 6x - \frac{1}{2}\}$. **5.8.** a) $\frac{a-6}{6}$; b) $\frac{5x-3a}{4}$; d) $\frac{41a-5}{12}$; e) $\frac{a^2+x^2}{2a}$; f) $-\frac{x^2+c^2}{2x}$. **5.9.** a) $\frac{a+x}{x}$; b) $\frac{2y-x}{x}$; d) $-\frac{2a+x}{ax}$; f) $\frac{x-5}{5x}$. **5.10.** d) $\frac{2x}{(1-3a)(x+2)}$; e) $\frac{7x^2}{(2x-1)(2y+3)}$. **5.11.** a) $\frac{y(x-y)}{x^2}$; b) $\frac{a(a+b)}{3b}$; g) $-\frac{a}{xyb}$; m) $\frac{1}{axy}$. **5.12.** d) $\frac{b}{4a}$; f) $\frac{x+2}{6}$; i) $9c^2 - b^2$. **5.14.** b) $-2x$; d) $q^2 - pq$; e) $-\frac{1}{4x}$; f) $\frac{30x^2+6y^2-16xy}{x(x^2+y^2)}$; g) 2; h) $2x(x+y)$; i) $a-2$. **5.15.** a) $\frac{1}{x^2+x+1}$; b) $\frac{1}{x^2+1}$; d) $\frac{a}{xy-a^2}$; e) $\frac{x^{11}-1}{x^{11}}$. **5.16.** l va 9. **5.19.** d) $\frac{1-x}{1+2x}$. **5.20.** a) ha; b) yo'q; d) ha; e) yo'q; f) yo'q; g) ha; h) yo'q; i) ha. **5.21.** a) $x \in \mathbb{Q}$; b) $\{(x \mid x = 2k, k \in \mathbb{Z})\}$; d) $x \geq -8$; e) $x \in \mathbb{R}$; f) $x > 0$; g) $x \in \mathbb{R}$; h) $x \in [-1; 1]$; i) $x \neq \pm 1$. **5.23.** g) 1989; h) $\frac{1}{8}$. **5.24.** a) $c^{\frac{2}{3}}$; b) \sqrt{b} ; d) $\frac{1}{m}$; e) y^3 . **5.26.** a) $x \leq 0$; b) $x \in \mathbb{R}$; d) $x \in \mathbb{R}$; e) $x \in \mathbb{R}$; f) $x \in \mathbb{R}$; g) $x \in \mathbb{R}$; h) $x \geq 0$; i) $x \in \mathbb{R}$; j) $x \in \emptyset$; k) $x \in \mathbb{R}$; l) $x \in \mathbb{R}$; m) $x = 3$. **5.27.** a) $x \leq 2$; b) $x \geq -3$; d) $x \geq 3$; e) $x \leq 4$; f) $x = 3$; g) $x = 3$; h) $x \in \emptyset$; i) $x = 1$; j) $x = -8$; k) $x = 8$; l) $x \in \{2; 4\}$; m) $x = 3$. **5.28.** a) 44; b) 15; d) 6; e) 6; f) 630; g) 120; i) 60; j) 0,015. **5.29.** a) $\frac{6}{7}$; b) $-\frac{4}{3}$; d) $\frac{2}{3}$; e) $\frac{3}{2}$; f) $\frac{5}{8}$; g) $\frac{4}{5}$; h) $\frac{3}{5}$; i) $\frac{1}{3}$. **5.30.** a) 225; b) 225; d) -25; e) $\frac{1}{9}$; f) $-x$; g) x^2 ; h) $x^2 + 1$; i) x^3 . **5.31.** a) $\sqrt[3]{16}$; b) $\sqrt[3]{76}$; d) $\sqrt[5]{4}$; e) $\sqrt[2]{25}$; f) $\sqrt[2]{x^2}$; g) \sqrt{x} ; h) $\sqrt[3]{x}$; i) \sqrt{x} . **5.32.** a) $\sqrt[4]{8}$; b) 4; d) $\sqrt[3]{-32}$; e) 2; f) $\sqrt[4]{x^3}$; g) x^4 ; h) $\sqrt[4]{(x+2)^5}$; i) x^8 . **5.33.** a) $\sqrt[6]{27}$ va $\sqrt[6]{16}$; d) $\sqrt[4]{25}$ va $\sqrt[4]{6}$; i) $\sqrt[20]{(x-y)^4}$ va $\sqrt[20]{y^5}$. **5.34.** f) $7\sqrt{2}$; h) $2\sqrt[3]{3}$; j) $|x^2 - 2|\sqrt{y}$; l) $(x-1)\sqrt[7]{z^2}$; m) $(y+1)^2\sqrt[3]{x^2}$. **5.35.** a) $\sqrt{80}$; b) $\sqrt[3]{-54}$; d) $-\sqrt[4]{162}$; e) $\sqrt[3]{96}$; f) $-\sqrt{x^2y^3}$; g) $\sqrt[5]{x^5y^3}$; h) $\sqrt[4]{x^8y^3}$; i) $-\sqrt[4]{x^{12}y^3}$; j) $\sqrt{(x-1)^8(y-2)}$; k) $-\sqrt[4]{(x-1)^{12}(y-2)}$; l) $-\sqrt[4]{x^4y}$; m) $-\sqrt{(7-4\sqrt{3})xy^3}$. **5.36.** a) $\sqrt{2}$; b) $6\sqrt{3}$; j) $2\sqrt[4]{8}$. **5.38.** a) $2\sqrt{3} < 3\sqrt{2}$; e) $3\sqrt[4]{4} < 3\sqrt[3]{2}$; f) $\sqrt{2} < \sqrt[3]{3}$; i) $\sqrt{8} < \sqrt[3]{19}$.

- 5.39. a) 20; b) $2\sqrt[3]{2}$; f) 6; i) $\sqrt[4]{12}$. 5.40. a) $\sqrt[6]{2}$; b) $\sqrt[3]{4}$; d) $\sqrt{6}$; e) $\sqrt[12]{\frac{16}{27}}$; f) $\sqrt[3]{a}$; g) $\sqrt[18]{a}$. 5.41. a) $x\sqrt[3]{16x}$; b) $24x^2$; d) $36x^2 - 9$, $|x| \geq \frac{1}{2}$; e) x^{16} ; g) $\sqrt[3]{(12 + xy^2)^2}$; h) $(xy + z)\sqrt{xy + z}$. 5.42. a) $\frac{2\sqrt{3}}{3}$; b) $\frac{5}{6}\sqrt[3]{18}$; d) $5 + 2\sqrt{6}$; e) $2 - \sqrt{2} + \sqrt{6}$; f) $4 + \sqrt[3]{75} + \sqrt[3]{45}$; l) $\frac{2(\sqrt{a} - \sqrt{x})}{a - x}$; h) $\frac{(x-y)\sqrt{x+y}}{x+y}$; o) $(1 + \sqrt{a})\sqrt{1 - \sqrt{a}}$. 5.43. a) $\sqrt{37} - \sqrt{2}$; b) $\sqrt{23} - \sqrt{6}$; d) 2; e) $2\sqrt{5}$. 5.44. a) to'g'ri; b) noto'g'ri; d) to'g'ri; e) to'g'ri. 5.45. e) $\sqrt[4]{18} + \sqrt[4]{2}$. 5.46. 2. 5.47. a) $a\sqrt[4]{b}(\sqrt[4]{a} + \sqrt[4]{b})$; b) 27; d) -1, agar $0 < a \leq 1$ va $-\left(\frac{\sqrt{1-a^2}+1}{a}\right)^2$, agar $-1 < a < 0$; e) 3; f) $\sqrt[6]{a}$; g) $9a$; h) $\frac{x^2}{2x-1}$; i) $\sqrt[3]{(a-b)^2}$. 5.48. 1. 5.49. 4.

VI bob

- 6.2. a) $X = R \setminus \{0; \pm 1\}$, $x = -2$. 6.3. a) $\frac{a-1}{3}$; b) $a = 1$ da yechim yo'q, $a \neq 1$ da $\frac{5}{a-1}$; e) $a = \pm 1$ da x ixityoriy son, $a \neq \pm 1$ da $x = 0$. 6.5. Yo'q. 6.6. Yo'q. 6.7. 15 yildan keyin. 6.8. a) -4.5; b) istalgan son; d) -1; e) ildizi yo'q. 6.10. a) $a \neq 1$ da $x = a - 1$, $a = 1$ da x - istalgan son; b) $a \neq \pm 1$ da $x = 0$, $a = \pm 1$ da x - istalgan son; g) $a \neq 1$ da $x = \frac{b+1}{a-1}$; $a = 1$, $b = -1$ da x - istalgan son; $a = 1$, $b \neq -1$ da ildizi yo'q. 6.12. f) $(x - 3)^2 - 1$; g) $a(x - 2a)^2 + 3$; i) $\left(x + \frac{a+b}{2}\right)^2 + \frac{(a-b)^2}{4}$. 6.15. Mumkin emas. Ko'rsatma: $z^2 - 15z + 70 = 0$ tenglama haqiqiy ildizga ega emasligidan foydalaning. 6.16. Ko'rsatma: $a^2 + b^2 = (a + b)^2 - 2ab$, $a^3 + b^3 = (a + b)^3 - 3ab(a + b)$. 6.17. Yo'q. 6.20. i) $a(x^2 - (\alpha + \beta)x + \alpha\beta) = 0$, $a \in R$, $a \neq 0$. 6.21. $14x^2 - 3x - 5 = 0$. 6.22. $\frac{1}{2}x^2 - \frac{1}{2}x - 3 = 0$. 6.23. -4.5. 6.24. 1. 6.25. 15. 6.26. $x = 5$. 6.27. $x \in R$, $x \neq \frac{2}{3}$. 6.28. $x \in R$, $x \neq -2$. 6.29. \emptyset . 6.30. $a \neq -c$, $c \neq 0$ da $x = \frac{a-c}{a+c}$, $a = -c$, $c = 0$ da \emptyset . 6.31. $a \neq 1$, $a \neq 2,25$, $a \neq -0,4$ da $x = \frac{31-2a}{4a-9}$; $a = 2,25$, $a = -0,4$ da \emptyset ; $a = 1$ da ma'noga ega emas. 6.32. $-\frac{11}{7}$ va 2. 6.33. -4 va 9. 6.34. 0 va 1. 6.35. 1. 6.43. Ko'rsatma: $a^3 + b^3 = (a + b)^3 - 3(a + b)ab$ tenglikdan foydalanib, o'ng tomonni $b^3 - 3b$ ko'rinishda tasvirlang (bu yerda $b = a + \frac{1}{a}$) va tenglamani $x^3 - b^3 = 3(x - b)$ tenglama bilan almashtiring. 6.44. -1; 1; 8. 6.53. -1; 2. 6.54. -2; 1. 6.55. $y = x^2 + 6x + 1$ ga nisbatan kvadrat uchhad sifatida qarang. 6.56. $y = (x^2 -$

- $-x + 1)^2$ ga nisbatan kvadrat uchhad sifatida qarang. **6.57.** Ko'rsatma: $2 \cdot \frac{x^2+36}{x^2-36} = \frac{x+6}{x-6} + \frac{x-6}{x+6}$. **6.58.** $-4; -2; -1$. **6.59.** $1; \frac{-1 \pm \sqrt{17}}{2}$. **6.60.** Ko'rsatma: $40 = 8 + 32$. **6.63.** -1 va 6 . **6.69.** $0, 2, 1 \pm \sqrt{2}$. **6.72.** Ko'rsatma: $x^2 - 5x + 6 = t$ deb oling. **6.73.** Ko'rsatma: $x^2 + 5x = t$ deb oling. **6.77.** \emptyset . **6.78.** $5, 5$ va 6 . **6.79.** $-5; 1; -1 \pm \sqrt{6}$. **6.80.** $\pm 2; \pm \frac{\sqrt[4]{24}}{2}$. **6.81.** Ko'rsatma: $x^2 + 2x = t$ deb oling. **6.82.** $-4; 2$.
- 6.113.** $\left[1; \frac{4}{3}\right]$. **6.114.** $(-\infty; -1] \cup [15; +\infty)$. **6.115.** $[-2; 1]$. **6.116.** R . **6.117.** \emptyset . **6.118.** $[-1; 1]$. **6.119.** R . **6.120.** $\{1\} \cup [2; 3]$. **6.121.** $x = -5/2$. **6.122.** $x = \pm 2$. **6.125.** $x = 4/3$. **6.126.** $x = 4, 5; x = 3, 25$. **6.127.** $x = \frac{\sqrt{113}-5}{4}$. **6.128.** $x = -\frac{2}{3}$. **6.129.** $(-\infty; 2/3]$. **6.130.** $[1; 3]$. **6.131.** $x = 0, 5; x = 3, 5$. **6.132.** $[2; +\infty)$. **6.133.** a) $x = 2; x = -6$. **6.134.** $\left[-2; 1 \frac{2}{3}\right]$. **6.135.** $\{0\} \cup (1; +\infty)$. **6.136.** $(-\infty; 0] \cup \{1; +\infty)$. **6.137.** $\left[-2 \frac{1}{6}; 1 \frac{1}{6}\right]$. **6.138.** $\left[\frac{5}{6}; +\infty\right)$. **6.139.** $[0; 13]$. **6.140.** $\{-4; -2; 0; 2; 4\}$. **6.141.** $[-3; 3]$. **6.142.** $(-\infty; 0] \cup \left[\frac{1}{2}; +\infty\right)$. Ko'rsatma: $|a-b| = |a| - |b| \Leftrightarrow (a-b), b \geq 0$. **6.143.** $\{0\}$.
- 6.144.** $\{0; 2\}$. **6.145.** $\{0\}$. **6.146.** $\{-1\}$. **6.148.** $a \leq 0$ da $x = -a$; $a > 0$ da $x = -7, x = a$. **6.149.** $a > 0$ da $\{-3a; a\}$; $a = 0$ da $x \neq 0$; $a < 0$ da \emptyset . **6.150.** $a \neq 0$ da $\left\{-\frac{5a}{3}\right\}$; $a = 0$ da $(-\infty; +\infty)$; **6.151.** $a \leq 0$ da $x = \frac{6a}{5}$; $a > 0$ da $x = \pm 2a$. **6.156.** $m = \pm \sqrt{15}$.
- 6.157.** $m \neq 2$ bo'lsa. **6.158.** $a = b = -3$. **6.159.** $m = 1, n = -30$. **6.160.** $2x + 1$. **6.161.** $\frac{r_1-r_2}{a-b}x + \frac{r_1b-r_2a}{b-a}$. **6.162.** b) $P(x) = D(x)(x^2 - x + 3)$; d) $P(x) = D(x)(2x^3 - 2x^2 - x - 4) + 6$; h) $P(x) = D(x)(x^3 - 3x^2 + 8x - 21)$; m) $P(x) = D(x)(x^4 - x^3 - 3x^2 - x - 1) - 4$. **6.163.** a) 2 ; b) 0 ; d) 3 . **6.164.** $a^3 + b^3 + c^3 - 3abc = (a+b+c)(a^2 + b^2 + c^2 - ab - bc - ac)$. Ko'rsatma: $a^3 + b^3 + c^3 - 3abc$ ni a ga nisbatan ko'phad deb qarang va $a = -b - c$ soni shu ko'phadning ildizi ekanini tekshirib ko'ring. **6.165.** b) $x = 2 \pm i$; e) $x = -2 \pm 3i$; g) $x = 4 \pm 5i$; i) $x = -0,5 \pm i$; k) $x = 1 \pm \frac{1}{4}i$; m) $x = 3 \pm \sqrt{2}i$. **6.166.** a) $(x+1-2i)(x+1+2i)$; b) $(x-1-3i)(x-1+3i)$; c) $(5z+5-i)(5z+5+i)$. **6.167.** a) $\pm 3i; \pm 2$; h) $z_{1,2} = \pm \frac{1+i\sqrt{3}}{2}, z_{3,4} = \pm \frac{1-i\sqrt{3}}{2}$.
- 6.168.** $ax^2 - 4ax + 13a = 0, a \neq 0, a \in R$. **6.169.** $ax^4 - 8ax^3 - 34ax^2 - 72ax - 65 = 0, a \neq 0, a \in R$. **6.171.** 3 karrali. **6.172.** a) $(x^2+3)(x^2-3x+3)(x^2+3x+3)$; b) $x^2(x-4i)(x+4i)$. **6.173.** a) 2 ; b) $-5; 3; 6$ d) ratsional ildizi yo'q; e) $\frac{1}{2}$; f) $\frac{1}{2}; -\frac{3}{2}$; g) -1 ; h) -3 ; 2. **6.174.** a) $-2; 1$; b) $-4; -2; -1$; d) butun yechimlari yo'q. **6.175.** a) $-2, \pm \sqrt{3}, \frac{1}{2}$; b) $\frac{1 \pm \sqrt{5}}{2}, -\frac{1}{2}, 2$; d) 1 ; e) $\pm 1, \frac{3 \pm \sqrt{73}}{8}$; f) $\pm 1, -\frac{2}{3}, 2$; g) $\pm 1,$

$\frac{7 \pm \sqrt{73}}{4}$. **6.177.** a) 0,79998; b) 0,03490482872567; d) -0,324617. **6.180.** $(-\infty; -1)$.

6.181. $(-4,6; +\infty)$. **6.182.** $\left(2\frac{13}{15}; +\infty\right)$. **6.183.** $\left(-\infty; 2\frac{28}{29}\right)$. **6.184.** $(-\infty; -1,5)$.

6.185. $(-\infty; 3)$. **6.186.** $[1; +\infty)$. **6.187.** $\left(-\infty; -\frac{2}{3}\right]$. **6.188.** $(3; +\infty)$. **6.189.** $(-\infty; -2)$.

6.190. $\left(-\infty; -1\frac{2}{3}\right)$. **6.202.** $y > \frac{3}{a^2+1}$. **6.205.** $\begin{cases} a > 0 \text{ da } x < \frac{b}{a}, \\ a = 0, b \leq 0 \text{ da } \emptyset, \\ a = 0, b > 0 \text{ da } x \in R, \\ a < 0 \text{ da } x > \frac{b}{a}. \end{cases}$ **6.214.**

a) $y < 3$ da; b) $y > 7$ da; d) $y > \frac{3}{17}$; e) $y < 0,1$ da. **6.215.** $a \in (5/3; \infty)$.

6.218. $\begin{cases} k > 0 \text{ da } x \in \left(-\infty; \frac{1-\sqrt{1+4k}}{2k}\right) \cup \left(\frac{1+\sqrt{1+4k}}{2k}\right), \\ k = 1 \text{ da } x \in (-\infty; -1), \\ -\frac{1}{4} < k < 0 \text{ da } x \in \left(\frac{1-\sqrt{1+4k}}{2k}; \frac{1+\sqrt{1+4k}}{2k}\right), \\ k \leq -\frac{1}{4} \text{ da } \emptyset. \end{cases}$

6.220. $\begin{cases} |k| > 2\sqrt{6} \text{ da } x \in \left(\frac{-k-2\sqrt{6}}{4}; \frac{-k+2\sqrt{6}}{4}\right), \\ |k| \leq 2\sqrt{6} \text{ da } \emptyset. \end{cases}$

6.221. $\begin{cases} k < 1 \text{ da } x \in (-\infty; 1 - \sqrt{1-k}) \cup (1 + \sqrt{1-k}; +\infty), \\ k = 1 \text{ da } x \in (-\infty; 1) \cup (1; +\infty), \\ k > 1 \text{ da } x \in (-\infty; +\infty). \end{cases}$

6.229. $x \in (-\infty; +\infty)$. **6.231.** $x \in (-\infty; 1) \cup (3; +\infty)$. **6.232.** $x \in \left(-\infty; -\frac{1}{3}\right) \cup (2; +\infty)$. **6.235.**

$x \in (-\infty; +\infty)$. **6.236.** $x \in (2; 5) \cup (12; +\infty)$. **6.237.** $x \in (-\infty; -7) \cup (-1; 4)$. **6.238.** $x \in (-\infty; -5) \cup (-1; 0) \cup (8; +\infty)$. **6.239.** $x \in (-48; 37) \cup (42; +\infty)$. **6.240.** $x \in (-\infty; -0,7) \cup (2,8;$

$9,2)$. **6.241.** $x \in (-17; -4) \cup (4; +\infty)$. **6.242.** $x \in \left(-\infty; -11\right) \cup \left(\frac{2}{3}; 11\right)$. **6.243.** $x \in (-\infty;$

$-5) \cup (0; 5)$. **6.244.** $x \in (-0,1; 0) \cup (0,1; +\infty)$. **6.245.** $x \in (-\infty; -3) \cup (-1; 1) \cup (3; +\infty)$.

6.246. $x \in (-6; 0) \cup (6; 15)$. **6.247.** $x \in (-2; 6)$. **6.248.** $x \in (-\infty; 0) \cup (4; +\infty)$. **6.249.**

$x \in (-\infty; 1) \cup (1; 24)$. **6.250.** $x \in (-\infty; -7) \cup (21; +\infty)$. **6.251.** $x \in (-\infty; -4) \cup (8; +\infty)$. **6.252.**

$x \in (-16; 11)$. **6.253.** $x \in [-1; 3)$. **6.254.** $x \in (-\infty; -4) \cup [6; +\infty)$. **6.255.** $x \in (-\infty; 1) \cup (1; 2) \cup$

$(4; +\infty)$. **6.256.** $x \in (-\infty; -1] \cup \{1; 2\} \cup [4; +\infty)$. **6.257.** $x \in \{-2\} \cup [1; 2]$. **6.261.**

$x \in (-\infty; 1)$. **6.262.** $(-\infty; -2) \cup (-2; 1) \cup (4; +\infty)$. **6.263.** $x \in (-\infty; -5] \cup \{1\} \cup [2;$

- $(-\infty; -2) \cup \left(-2; \frac{1}{2}\right) \cup (1; +\infty)$. **6.280.** $(-2; -1) \cup (1; 2)$. **6.281.** $[-3; 3]$. **6.282.**
 $(-\infty; 2) \cup (5; +\infty)$. **6.283.** $(-\infty; 1)(1,5; +\infty)$. **6.284.** $(-\infty; 2,5) \cup \left(\frac{33}{8}; +\infty\right)$. **6.285.**
 $(-6; 3)$. **6.286.** $(-\infty; 1) \cup (4; +\infty)$. **6.287.** $(-3; 1)$. **6.288.** $(-\infty; 0) \cup (4; +\infty)$. **6.290.**
 $(-\infty; +\infty)$. **6.291.** $\left(-\frac{1}{2}; 2\right)$. **6.299.** $(-\infty; -3) \cup \left(-\frac{\sqrt{7}}{2}; \frac{\sqrt{7}}{2}\right) \cup (4; +\infty)$. **6.300.**
 $[1; 2) \cup (3; 4]$. **6.302.** $(-\infty; 1) \cup (1; +\infty)$. **6.303.** $(-\infty; -2) \cup (-1; 0) \cup \left(\frac{1}{2}; +\infty\right)$. **6.306.**
 $(-\infty; -4] \cup [-2; -1]$. **6.307.** $(-2; -1) \cup (2; 3)$. **6.318.** $\{1\}$. **6.319.** $\left\{\frac{3}{2}\right\}$. **6.320.** $(-\infty; +\infty)$.
6.321. $x = 4$. **6.322.** $(-\infty; +\infty)$. **6.323.** $(-\infty; 4) \cup (4; +\infty)$. **6.324.** $\{\pm 1\}$. **6.325.** $(-\infty; 1) \cup$
 $\cup (-1; 1) \cup (1; +\infty)$. **6.326.** $R \setminus \{2\}$. **6.327.** $[-1; 1]$. **6.328.** $(-\infty; +\infty)$. **6.329.** $[0; 3]$.
6.330. $(2; 4)$. **6.331.** $(-\infty; 1) \cup (3; +\infty)$. **6.332.** $\left(-\infty; -\frac{2}{3}\right] \cup \left[\frac{1}{2}; +\infty\right)$. **6.333.**
 $\left(\frac{11-\sqrt{57}}{4}; \frac{11+\sqrt{57}}{4}\right)$. **6.334.** $(8; +\infty)$. **6.335.** $(-3; 4)$. **6.336.** $(-\infty; -2) \cup (-1; +\infty)$. **6.338.**
 $[1; 6]$. **6.339.** \emptyset . **6.340.** $(-\infty; -3]$. **6.341.** $\left[-2; 3\frac{2}{3}\right]$. **6.342.** $[-3; 5]$. **6.343.**
 $\left(-\frac{4}{7}; +\infty\right)$. **6.344.** $(-\infty; 1) \cup (7; +\infty)$. **6.345.** $(-\infty; 1)$. **6.346.** $(-\infty; 2) \cup (3,5; +\infty)$.
6.347. $(-\infty; 1] \cup [3; +\infty)$. **6.348.** $(-\infty; -1) \cup (0; 1) \cup (1; +\infty)$. **6.349.** $(2; 3) \cup (3; +\infty)$.
6.350. $(-\infty; -6) \cup [-3,5; +\infty)$. **6.351.** $\left(3; 3\frac{1}{3}\right)$. **6.352.** $\left[0; 1\frac{3}{5}\right] \cup [2,5; +\infty)$. **6.353.**
 $(-\infty; -2) \cup (-2; -1) \cup (1; 0]$. **6.354.** $(-\infty; 2)$. **6.355.** $[\sqrt{6} - 2; 1) \cup (1; 4]$. **6.356.**
 $(-\infty; 1) \cup [5; +\infty)$. **6.359.** $\left(-\infty; \frac{1+\sqrt{17}}{4}\right]$. **6.360.** $(-3; 3]$. **6.361.** $(1 - \sqrt{3}; 2 - \sqrt{2})$.
6.362. $\left(-\infty; \frac{4-\sqrt{19}}{3}\right) \cup \left(\frac{4-\sqrt{19}}{3}; +\infty\right)$. **6.380.** a) $(4; -1)$; b) $\left(\frac{9}{11}; \frac{7}{11}\right)$; d) $(t; 5 -$
 $- t)$. $t \in R$; e) $(4; -3)$; f) $(6; 9)$; g) \emptyset . **6.381.** a) $(1; 2)$; b) \emptyset ; d) $\left(t; \frac{7-2t}{3}\right)$,
 $t \in R$; e) $\left(\frac{1}{4}; \frac{1}{2}\right)$; f) $\left(\frac{7}{11}; \frac{3}{13}\right)$. **6.382.** a) $(1; 1; -1)$; b) $(1; -1; 1)$; d) $(-1; 1;$
 $1)$; e) $(1; 1; 1)$; f) $(1; -1; -1)$; g) $(-1; -1; 1)$. **6.383.** a) $(1; 0)$, $(0; -1)$; b) $(5/4;$
 $-1/8)$, $(-1; 1)$; g) $(-4; -5)$; $(6; -5)$. **6.384.** a) $(2; 3)$, $(3; 2)$; e) $(2; -3)$, $(3; -2)$.
6.385. a) \emptyset ; b) \emptyset ; d) $(1 - t; t)$, $t \in R$. **6.386.** a) $(-2; -4)$, $(-4; -2)$, $(2; 4)$,
 $(4; 2)$; b) $(2; 8)$, $(8; 2)$, $(-2; -8)$, $(-8; -2)$; d) $\left(-\frac{9}{5}; -\frac{16}{5}\right)$, $\left(\frac{9}{5}; \frac{16}{5}\right)$;
e) $(-3; -2)$, $(3; 2)$; f) $(-7; -3)$, $(7; 3)$; h) ko'rsatma: bir jinsli tenglama
hosil qiling; h) $(-3; -2)$, $(3; 2)$. **6.387.** a) $(1; 2)$, $(2; 1)$; b) $(-3; -5)$,
 $\left(-\frac{5}{3}; -\frac{13}{3}\right)$, $\left(\frac{5}{3}; \frac{13}{3}\right)$, $(3; 5)$; d) $(-4; -5)$, $(-3\sqrt{3}; -\sqrt{3})$, $(3\sqrt{3}; \sqrt{3})$, $(4;$

5); e) (1; -1), (3; -3), $\left(\sqrt{157} - 13; \frac{\sqrt{157}-13}{2}\right)$, $\left(-13 - \sqrt{157}; -\frac{13+\sqrt{157}}{2}\right)$;

f) (2; -3), (t; 1), $t \in R$; g) (-1; 3), (t; 2), $t \in R$; h) (2; -1), (-1; t), $t \in R$;

i) (-1; -2), $(-\sqrt{2}; -\sqrt{2})$, (1; 2), $(\sqrt{2}; \sqrt{2})$. **6.388.** a) (5; 1), (1; 5), (3; 2),

(2; 3); b) (2; 1), (-1; -2), $(1 - \sqrt{2}; 1 + \sqrt{2})$, $(1 + \sqrt{2}; 1 - \sqrt{2})$; d) (-2; -4),

$\left(\frac{5}{3}; \frac{10}{3}\right)$; e) (1; 4), (-5; -4), (5; -4), (-1; -4). **6.389.** a) (2; 3), (3; 2);

b) (-3; -1), (-1; -3), (1; 3), (3; 1); d) (-1; -2), (2; 1); e) (2; -1), (-1; 2);

f) (-1; -2), (2; -1). Ko'rsatma: ikkinchi tenglamani 3 ga ko'paytirib, birinchi tenglamaga qo'shing; g) (-3; -2), (-2; -3), (2; 3), (3; 2). Ko'rsatma:

birinchi tenglamadan $x^2 + y^2 = \frac{78}{xy}$ ekani topiladi. Bu tenglamani kvadratga

ko'taring; h) (4; 8), (8; 4). **6.390.** a) (1; 3; 9), (9; 3; 1); b) $\left(\frac{12}{7}; \frac{12}{5}; -12\right)$;

d) $\left(\frac{1}{\sqrt{3}}; \frac{1}{\sqrt{3}}; \frac{1}{\sqrt{3}}\right)$; e) (2; 1; 3), (-2; -1; -3). **6.392.** a) -15; b) 3; f) 0; g) 0;

h) 1; i) $x^2(x^2 - 1)$. **6.393.** a) $a = 6$; b) $a = -2$; d) 0; e) a - ixtiyoriy son. **6.394.**

a) ± 2 ; b) 0; d) \emptyset . **6.396.** d) $x \in R$; e) $x \in R$. **6.397.** a) $8\frac{172}{495}$; b) 3, (13). **6.398.**

a) -80; b) 6; d) -72; e) 0; f) 36; g) -90. **6.399.** a) $\frac{2}{3}$; b) 0 va 6; e) \emptyset . **6.400.**

a) -23; b) 6; d) $2a - 5$; e) $-4a + 13b$. **6.401.** a) $\Delta_x = 7$; $\Delta_y = -1$; e) $\Delta_x = -35$; $\Delta_y = 30$. **6.402.** a) (-5; 2); b) (2; 1); d) (6; 5); e) (5; -2); f) \emptyset ; g) \emptyset ; h) \emptyset ;

i) \emptyset ; j) (t; t - 1), $t \in R$; k) $\left(t; \frac{3t}{5}\right)$, $t \in R$; **6.405.** $a = 1$, $b = -1$. **6.406.** a) (1; -1),

(1; -2), (-1; -1), (-1; 2). **6.407.** $a = 4$. **6.408.** $a = 3$. **6.409.** a) \emptyset ; e) $\left(3 - 2y; y; \frac{3y+1}{2}\right)$.

$y \in R$. **6.410.** $a \in \left[\frac{2}{3}; 3 - \sqrt{5}\right]$ da $\left(\frac{4a-a^2}{2a-4}; \frac{a-4}{a-2}\right)$, $a \in (3 - \sqrt{5}; 2]$ da

$\left(\frac{a^2-12a+8}{6a-4}; \frac{a}{3a-2}\right)$. **6.411.** $a = 7 - 4\sqrt{3}$ da $(0; 1 - 2\sqrt{3})$, $a = 7 + 4\sqrt{3}$ da

$(0; 1 + 2\sqrt{3})$, $a = 1$ da (6; -11). **6.412.** 28 m. **6.413.** 2.5 t. **6.414.** 8 kunda. **6.415.**

21 qator. **6.416.** 20 km/soat. **6.417.** 20 km/soat. **6.418.** 7 km/soat. **6.420.** 5 soat,

7 soat. **6.421.** 30 kunda, 20 kunda. **6.423.** 18 km/soat, 24 km/soat. **6.425.** 11 ta.

6.426. 22 kishi. **6.427.** 30 o'quvchi. (Eslatma: 12. 13- masalada 42 ta vektor

hosil bo'ladi.) **6.428.** 7 ta. **6.429.** Sakkizburchak. **6.430.** 40 km/soat. **6.431.** 30

km/soat. **6.432.** 10 sm va 4 sm. **6.433.** 15 sm; 8 sm. **6.435.** 12 sm; 16 sm; 20 sm.

6.436. 36; 4. **6.437.** 40 km/soat; 30 km/soat. **6.438.** 36 km/soat; 24 km/soat.

6.439. 36 km/soat; 30 km/soat. **6.440.** 10 soat; 6 soat. **6.441.** 60 soat; 84 soat.

6.422. 18 va 12. **6.443.** a) $\left(-5; -\frac{3}{2}\right) \cup \left(\frac{1}{2}; 1\right)$; b) $\left[-\frac{1}{2}; \frac{1}{2}\right]$; d) (0; 1); e) (-4;

-3) \cup [-2; -1] \cup [1; 2). **6.451.** \emptyset . **6.452.** \emptyset . **6.453.** \emptyset . **6.454.** \emptyset . **6.455.** \emptyset . **6.456.** \emptyset .

6.457. \emptyset . **6.458.** \emptyset . **6.459.** \emptyset . **6.460.** \emptyset . **6.461.** \emptyset . **6.462.** $x = 3$. **6.463.** $x = 0.5$. **6.464.** \emptyset .

- 6.465.** $\left\{\frac{1}{2}; 1\right\}$. **6.466.** $\{-1; 2\}$. **6.467.** $\{-3; 2\}$. **6.468.** $\{-4; 3\}$. **6.469.** $x=3$. **6.470.** $x=3$.
6.471. $x=8$. **6.472.** $x=28$. **6.473.** $x=0$. **6.474.** $x=4$. **6.475.** $x=19$. **6.476.** $x=3$.
6.477. $x=6$. **6.478.** $x=-1$. **6.479.** $x=3$. **6.480.** $x=2$. **6.482.** $x = -1 \pm 2\sqrt{17}$. **6.483.**
 \emptyset . **6.484.** $x=-5, x=0$. **6.485.** $-3\frac{3}{8}; 1$. **6.486.** $-8; 27$. **6.487.** $8; 27$. **6.488.** $x=3$.
6.489. $x=1$. **6.490.** $\left\{-\frac{3}{2}; \frac{1}{2}\right\}$. **6.491.** $x=2,5$. **6.492.** $x=8$. **6.493.** $x=5$. **6.494.**
 $x = \frac{7 \pm \sqrt{153}}{16}$. **6.495.** $x=2$. **6.496.** $x=3$. **6.497.** \emptyset . **6.498.** $x=-61, x=30$. **6.499.**
 $x=8, x=8 \pm 4\sqrt{3}$. **6.500.** $x=-6, x=-5, x=-\frac{11}{2}$. **6.501.** $x=-1$. **6.502.** $x=0$.
6.503. $x=3, x=4$. **6.504.** $x=0$. **6.505.** $x=9$. **6.506.** $x=2; x=3$. **6.507.** $x=-61, x$
 $=30$. **6.508.** $x = -2\frac{2}{3}, x=1$. **6.509.** $x = -\frac{1}{3}, x=1$. **6.510.** $x=\pm 4$. **6.511.** $x=-1$.
6.512. $x=4$. **6.513.** \emptyset . **6.514.** $x=-1, x=4$. **6.515.** $[2; +\infty)$. **6.516.** $[5; 8]$. **6.517.**
 $x = -\frac{1}{11}$. **6.518.** $x = \frac{5}{11}$. **6.519.** $x = \frac{\sqrt{5}}{2}$. **6.520.** $x=2$. **6.521.** $\frac{\sqrt{5}}{2}$. **6.522.** $a < 0$ da
 $\emptyset, a \geq 0$ da $x = a^2 - 1$. **6.523.** $a < -3$ da $\emptyset, a \geq -3$ da $x = \frac{a-3}{2}$. **6.524.** $a \neq 0$ da
 $x = \frac{5a}{3}; a = 0$ da $(-\infty; 0) \cup (0; +\infty)$. **6.525.** $a \in (-\infty; 2) \cup (2\sqrt{2}; +\infty)$ da \emptyset ;
 $a \in [2; 2\sqrt{2}]$ da $x = 5 \pm \frac{a\sqrt{8-a^2}}{2}$. **6.526.** $a < 0$ da $\emptyset, 0 \leq a \leq \frac{1}{2}$ da
 $x = a + 1 \pm \sqrt{2a}; a > \frac{1}{2}$ da $x = a + 1 + \sqrt{2a}$. **6.527.** $x = \frac{\sqrt{2}(1-\sqrt{2\sqrt{3}-3})}{\sqrt{3}-1}$.
6.528. $[-3; +\infty)$. **6.529.** $(-\infty; +\infty)$. **6.530.** $(-\infty; +\infty)$. **6.531.** \emptyset . **6.532.** $(-\infty; +\infty)$.
6.533. \emptyset . **6.534.** $(-\infty; +\infty)$. **6.535.** $x \neq 0$. **6.536.** \emptyset . **6.537.** \emptyset . **6.538.** $(-\infty; 1] \cup$
 $\cup [2; +\infty)$. **6.539.** $y \neq -1/2$. **6.540.** $(-\infty; +\infty)$. **6.541.** $(2; 3)$. **6.542.** \emptyset . **6.543.** \emptyset .
6.544. $\{-1\} \cup [2; +\infty)$. **6.545.** $\{-2; 1\} \cup [3; +\infty)$. **6.547.** $(-\infty; -8,5] \cup [1; 10)$.

VII bob

- 7.1.** $x \neq 2$. **7.2.** $x \neq 3, 4$. **7.4.** $x \neq -2$. **7.6.** $x \neq 1, x \neq 2, x \neq 3$. **7.7.** $x \neq 3, x \neq 4$. **7.10.**
R. 7.12. $x \neq 2$. **7.13.** $x \neq 3$. **7.14.** R . **7.16.** $x \neq 0, x \neq \pm 1$. **7.18.** $x \neq 0$. **7.19.** $x \neq 0, x \neq 2$,
 $x \neq 3$. **7.26.** $\left(-\frac{\sqrt{2}}{3}; +\infty\right)$. **7.27.** $(-\infty; -2(\sqrt{3}+2))$. **7.28.** $\{1; 2\}$. **7.29.** $x \neq -8/7$. **7.32.**
 $(-\infty; 2]$. **7.33.** $\{0\} \cup [1; +\infty)$. **7.34.** $\{0\} \cup [2; +\infty)$. **7.35.** $\{2\}$. **7.40.** $[-0,5; 0,5]$. **7.41.** $[-2;$
 $0] \cup \{1,5\}$. **7.42.** $\{1\} \cup [2; 3) \cup (3; +\infty)$. **7.43.** $\{0,5\}$. **7.49.** $(-\infty; 3]$. **7.50.** $(-\infty; 2,25]$. **7.52.**
 $(-\infty; 0) \cup (0; +\infty)$. **7.53.** $(-\infty; 1) \cup (1; +\infty)$. **7.54.** $(0; 1]$. **7.55.** $(-\infty; -2] \cup [2; +\infty)$. **7.57.**
 $[-2; +\infty)$. **7.58.** $(-\infty; 5]$. **7.60.** $[2; +\infty)$. **7.61.** $(-\infty; -2]$. **7.62.** $[1; +\infty)$. **7.63.** $[0; 1]$.
7.64. $[-4; 1]$. **7.65.** $[-1; 2)$. **7.66.** $[-2; 1]$. **7.67.** $[-1; 3]$. **7.68.** $[-3; +\infty)$. **7.69.**
 $[3; 12) \cup (123; +\infty)$. **7.70.** $[6,75; +\infty)$. **7.84.** $\frac{1 \text{ mil. yil}}{1 \text{ h.-qam. yil}} = \frac{365,25}{354,3671} \Rightarrow 1$

h.-q. yil $\approx 0,9702$ m. yil yoki 1 m. yil $\approx 1,0307$ h.-q. yil. M milodiy (yil, oy, kun) dan $H(t)$ hijriy (yil, oy, kun) ga o'tish: $H(t) = 1,0307t$, bunda $t = M - 622$ - yil 16- iyul; H hijriy-qamariy (yil, oy, kun) dan $M(t) = 0,97202 \cdot H(t) + 622$ - yil 16- iyul, bunda 622- yil 16- iyul hijriy hisobning boshi. **7.97.** Ko'rsatma:

$$\frac{3x-1}{x+2} = t \text{ deb oling va } f(t) \text{ ni toping. } \mathbf{7.102.} \quad M'(-3; 10), \quad N'(-1; -4), \quad P(0; 1),$$

$Q(2; -1)$. **7.106.** Koordinatalar boshini $L(a; b)$ nuqtaga parallel ko'chirish va $k = 2$ koeffitsiyentli gomotetiyanidan foydalaning. **7.119.** a) tenglama $y = ax^2 + bx + c$ ifodadagi noma'lum a, b, c koeffitsiyentlarni topish uchun x va y lar o'rniga A, B, C nuqtalarning koordinatalari qo'yiladi va

$$\begin{cases} -1 = a \cdot 2^2 + b \cdot 2 + c, \\ 3 = a \cdot 1^2 + b \cdot 1 + c, \\ 2 = a \cdot 0^2 + b \cdot 0 + c \end{cases} \text{ sistema tuziladi. Undan } c = 2, a = -2,5, b = -1,5. \text{ Javob:}$$

$y = -2,5x^2 - 1,5x + 2$. **7.120.** 1) $M(x_0; y_0)$ nuqta $y = ax^2$ da yotganligidan $y_0 = ax_0^2$, shu kabi $M'(x_1; y_1)$ nuqta $y = k(x - x_0) + y_0$ kesuvchi to'g'ri chiziqda yotadi. Shunga ko'ra, $y_1 = k(x_1 - x_0) + y_0$ yoki $ax_1^2 = k(x_1 - x_0) + ax_0^2$, bundan $x_1 = \frac{k}{a} - x_0$. Kesuvchi urinmaga aylanganida M va M' nuqtalar

ustma-ust tushadi. Shunga ko'ra, $x_1 = x_0$ va $x_0 = \frac{k}{a} - x_0$ yoki $k = 2ax_0$. **7.134.**

a) juft; b) juft; d) juft; e) juft. **7.135.** d) toq; e) juft. **7.136.** a) juft; b) toq; d) juft; e) toq. **7.137.** a) toq; b) juft; d) juft; e) juft. **7.141.**

$y = \frac{3}{8}x^2 - \frac{9}{4}x + 3$, na toq, na juft. **7.153.** a) $\pm \frac{2\sqrt{3}}{3}$; d) \emptyset ; f) \emptyset ; h) 1. **7.154.**

$(-\infty; +\infty)$ da kamayadi. **7.155.** $(-\infty; +\infty)$ da o'sadi. **7.164.** $y_{\max} = 1, x_{\max} = 1$. **7.166.**

$y_{\max} = \frac{1}{12}, x_{\max} = 1,5$. **7.174.** $y_{\max} = 0, x_{\max} = -2,7$. **7.179.** (80- rasm). **7.182.** (81-

rasm). **7.187.** (82- rasm). **7.204.** Masalan, $y = 1,75x - 51,25, y = 1,8x - 54,2$.

7.205. $y = \frac{2}{7}x$. **7.207.** Jadval qiymatlari bo'yicha chizilgan shakl giperbolaga

o'xshash. Tenglamani $l = \frac{a}{R} + b$ ifoda ko'rinishida izlash mumkin. Noma'lum a va b larni topish uchun jadvaldan ixtiyoriy ikki $(x; y)$ juft qiymat

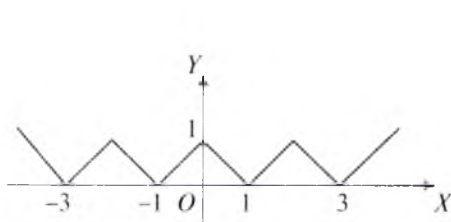

80- rasm.

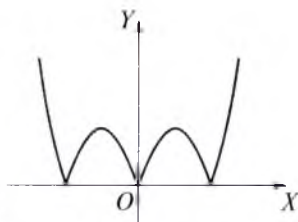

81- rasm.

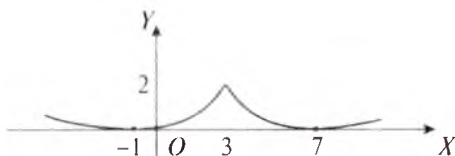

82- rasm.

ifodaga qo'yilib, sistema tuziladi va undan a va b lar aniqlanadi. Masalan, (20;

$$4,99), (80; 1,25) \text{ lar bo'yicha tuzilgan } \begin{cases} 4,99 = \frac{a}{20} + b, \\ 1,25 = \frac{a}{80} + b \end{cases} \text{ sistemadan } a = 100, b =$$

$= -0,01$ aniqlanadi. Natijada $I = \frac{100}{R} - 0,01$ olinadi.

VIII bob

8.4. Manfiy. **8.11.** a) $y = 0,2^x$; b) $(-2)^x$, x - butun toq son. **8.12.** b) 1) $K_d = 1/(1 + 0,1)^1 = 0,9091$, $K_d = 1/(1 + 0,1)^2 = 0,8264$, $K_d = 1/(1 + 0,1)^3 = 0,7513$, $K_d = 1/(1 + 0,1)^4 = 0,6830$; 2) $D_1 = 30000 \cdot 0,9091 = 27273$ so'm, $D_2 = 40000 \times \times 0,8264 = 33056$ so'm, $D_3 = 50000 \cdot 0,7513 = 37565$ so'm, $D_4 = 60000 \cdot 0,6830 = 40980$ so'm; 3) korxonaning oldingi yillardagi jami daromadi 97794 so'm. Kreditga bu daromad to'lansa ham yana 100000 - 97794 = 2206 so'm yetmaydi. Uni qoplash uchun 4- yil daromadining 2206/40980 $\approx 0,605$ qismi, ya'ni $0,605 \cdot 12 = 7,26$ oy, ya'ni 70 yil 7,8 kunlik daromadini ham beradi va olgan

kreditini batamom to'laydi. **8.15.** a) $\frac{1}{3}$; b) $\frac{1}{12}$; d) -7; e) $\frac{2}{3}$; f) $-\frac{1}{2}$; g) -2,5.

8.16. a) 100; b) 6; d) $\frac{1}{9}$; e) 4. **8.20.** f) 3. **8.29.** $\frac{y_{n+1}}{y_n} = k$, $0 < k \neq 1$ bo'lsin. Ifodani

logarifmlab, $\lg|y_{n+1}| - \lg|y_n| = \lg k$ ni olamiz. Demak, $z = \lg|y|$ funksiyaning chekli ayirmalari doimiy: $\Delta z = c$. Funksiyani $z = \alpha x + \beta$ yoki $\lg|y| = \alpha x + \beta$ ko'rinishda berish mumkin. Bundan $y = 10^{\alpha x + \beta}$ yoki $y = A \cdot a^x$, bunda $A = 10^\beta$,

$a = 10^\alpha$. **8.31.** a) 10; b) 890; d) $a + b$. **8.32.** a) $x = \frac{(a+b)^2 \sqrt{a}}{(a-b)^3}$;

b) $x = (a-b)a^{\frac{2}{3}}b$. **8.41.** b) 2; k) $x = 1$; l) $x = \log_{15} 5$; m) $x = 2$; o) $x = \pm 1$;

p) $x = 0$, $x = 2$; q) $x = 0$, $x = \pm 1$; r) $x = \frac{\lg 3}{\lg 2}$; s) $x = 0$, $x = \log_{2,5} 1,5$; t) $x = \pm 2$;

u) $x = 3$. Ko'rsatma: v , x , y , z , o' tenglamalarni yechishda funksiyalarning monotonlik xossalariidan foydalaning. **8.42.** g) $(-\infty; -3) \cup (-1; +\infty)$; h) $[1; +\infty)$; i) $[-\log_3 2; 0]$; j) $[2; +\infty)$; k) $(-\infty; 0] \cup [2; +\infty)$; l) $(-\infty; +\infty)$; m) $(x \in R)$; n) $\{1, 2,$

3, 4, 5, 6, 7}; o) $(-\infty; \log_{0.4}2)$; p) $(-2; +\infty)$; q) $\{-1; 0\} \cup [2; 3]$; r) $(-\infty; 1) \cup (0; 2)$; s) $(-\infty; \log_2(\sqrt{2}-1) \cup [\frac{1}{2}; +\infty)$; t) $(\frac{5}{3}; 2)$; u) (1; 4). **8.44.**

a) $\frac{25 \pm \sqrt{7}}{8}$; l) $x = 2$; m) $x = 4$; n) $x = 2$; o) $x = 0$; p) $x = 100$;

q) $x = -2 - \sqrt{10}$; r) $x = 3^{-\sqrt{2}}, x = 3^{\sqrt{2}}$; s) $x = \sqrt{5}, x = 5$; t) $x = -1, x = 0$;

u) $x = -\frac{9}{5}, x = 23$; v) $x = 10$. Ko'rsatma: x, y, z, o', g' tenglamalarni

yechishda funksiyalarning monotonlik xossalariidan foydalaning. **8.45.** f) $x >$

>1000 ; l) $(\frac{1}{5}; \frac{2}{5})$; m) $(\frac{1}{3}; 2)$; n) $(0; \frac{1}{2}] \cup (2; 4]$; o) $(-\frac{4}{3}; -\frac{17}{22})$; p) (2;

2,5); q) $(\log_3 10; +\infty)$; r) $(0; \frac{1}{2}) \cup (1; 2) \cup (3; 6)$; s) $(-2; -1) \cup (-1; 0) \cup (0; 1) \cup (2;$

$+\infty)$; t) $(-1; -\frac{2}{\sqrt{5}}) \cup (\frac{2}{\sqrt{5}}; 1)$; u) $(0; \frac{1}{2}) \cup (\sqrt{2}; +\infty)$. **8.46.** (2; 4). **8.47.** (2; 1).

8.48. (8; 2). **8.49.** (1; 1). **8.50.** (4; 1). **8.51.** (2; 4). **8.52.** (4; 3). **8.53.** (2; 8). **8.54.**

(1; 1), (9; 27). **8.55.** (1; 1); $(\frac{1}{4}; \frac{1}{2})$. **8.56.** a) (1; 2); b) (0; 3); d) (2; 1000).

(2; 0,001); e) (ko'rsatma: sistemani $\begin{cases} \lg|x| + \lg|y| = 1 + \lg 4, \\ \lg y \cdot \lg x = \lg 4 \end{cases}$ ko'rinishga

keltiring.) (10; 4), (4; 10), (-10; -4), (-4; -10). **8.79.** 9. **8.80.** -3; 5. Ko'rsatma:

$33 + \sqrt{128} = (\sqrt{32} + 1)^2$. **8.81.** 5. **8.82.** 0. **8.83.** $\pm 2; -1$. **8.84.** 1. **8.85.** 0,001; 10. **8.86.**

-2. **8.87.** 2. **8.88.** 1. **8.89.** 1. **8.90.** 9. **8.91.** $\log_3 10; \log_3 28 - 3$. **8.92.** 1. **8.93.** 1. **8.94.** 100.

8.95. $\pm \frac{1}{2}$. **8.96.** $-\frac{13}{5}; -2$; 3. **8.97.** -1. **8.98.** -64; -1. **8.99.** $-\frac{1}{4}$. **8.100.** $\frac{1}{4}$. **8.101.** $-\frac{2}{3}$.

8.102. 3. **8.103.** $(\frac{1}{2}; +\infty)$. **8.104.** [0; 1]. **8.105.** $(-\infty; -6) \cup (2; +\infty)$. **8.106.** [-2; -1).

8.107. $(-\frac{3\sqrt{5}+1}{2}; -2) \cup (1; \frac{3\sqrt{5}+1}{2})$. **8.108.** $[\frac{3}{4}; 1)$. **8.109.** $(-\frac{3\sqrt{5}}{5}; -1) \cup$

$(1; \frac{3\sqrt{5}}{5})$. **8.110.** (0; 3). **8.111.** (0; -3). **8.112.** (1; 2). **8.113.** $(\sqrt{2}; \frac{1}{\sqrt{2}})$; (2; 1).

8.114. (125; 4), (625; 3). **8.115.** $(\frac{1}{4}; \frac{1}{9})$.

ADABIYOT

1. Abduhamidov A., Nasimov H.A. Algebra va matematik analiz asoslari. I qism. «Istiqbol», T., 2000.
2. Abduhamidov A., Nasimov H.A. Algebra va matematik analiz asoslari. II qism. «Istiqbol», T., 2000.
3. Abduhamidov A., Musurmonov O.L., Nasimov H.A. Matematika tarixidan lavhalar. «Matbaa tongi», T., 2000.
4. Alimov Sh.A va b. Algebra va analiz asoslari, 10–11. «O'qituvchi», T., 1996.
5. Башмаков М.И. Алгебра и начала анализа, 10–11. «Просвещение», М., 1999.
6. Вересова Е.Е. и др. Практикум по решению математических задач. «Просвещение», М., 1979.
7. Vilenkin N.Y. va b. Algebra va matematik analiz, 10. «O'qituvchi», T., 1992.
8. Galitskiy M.L. va b. Algebra va matematik analiz kursini chuqur o'rganish. «O'qituvchi», T., 1985.
9. Глейзер Г.Д. и др. Алгебра и начала анализа. «Просвещение», М., 1989.
10. Gnedenko B.V. va b. «Yosh matematik» qomusiy lug'ati. «O'zME», T., 1992.
11. Говоров В.М. и др. Сборник конкурсных задач по математике. «Наука», М., 1983.
12. Карп А.П. Сборник задач по алгебре и началам анализа. «Просвещение», М., 1995.
13. Kolmogorov A.N. va b. Algebra va analiz asoslari, 10–11. «O'qituvchi», T., 1992.
14. Потапов М.К. и др. Алгебра и анализ элементарных функций. «Наука», М., 1981.
15. To'laganov T.R. Elementar matematika. «O'qituvchi», T., 1997.
16. Umirbekov A.U., Shaabzalov Sh.Sh. Matematikani takrorlang. «O'qituvchi», T., 1989.
17. Bittinger L.Marlin, Beecher A.Judith. Development Mathematics. Addison-Wesley. Indiana University, USA, 2000.
18. Nassiet S., Torte D., Rivoallan L. Matematikayes Analyse. Didier, Paris, 1995.
19. Donkemts G. Matematikayes Analyse. Didier, Paris, 1995.

MUNDARIJA

To'zboshi	3
I BOB. TO'PLAMLAR NAZARIYASI VA MATEMATIK MANTIQ ELEMENTLARI	
1- §. To'plamlar nazariyasining asosiy tushunchalari	4
1. To'plam haqida tushuncha	4
2. To'plamlar ustida amallar	9
3. To'plam elementlarining soni bilan bog'liq ayrim masalalar	14
2- §. Matematik mantiq elementlari	16
II BOB. HAQIQIY SONLAR	
1- §. Natural sonlar	22
1. Tub va murakkab sonlar	22
2. Eng katta umumiy bo'luvchi. Eng kichik umumiy karrali. Yevklid algoritmi	28
3. Sonlarning bo'linish belgilari	33
2- §. Ratsional sonlar	37
1. Butun sonlar. Oddiy kasrlar	37
2. O'nli kasrlar	41
3. Davriy o'nli kasrlarni oddiy kasrlarga aylantirish	44
3- §. Haqiqiy sonlar va ular ustida amallar	46
1. Irratsional sonlar	46
2. Sonli to'plamlarni ajratuvchi son	49
3. Haqiqiy sonlar ustida arifmetik amallar	51
4. Haqiqiy sonning moduli	56
5. Haqiqiy sonning butun va kasr qismi	59
6. Proporsiya	62
7. Protsent (foiz)lar	64
8. Taqqoslamalar	68
4- §. Koordinatalar o'qi va koordinatalar tekisligi	75
1. Yo'naltirilgan kesma, to'g'ri chiziqdagi koordinatalar	75

2. Koordinata tekisligi	80
5- §. Induksiya. Matematik induksiya metodi	83
1. Induksiya	83
2. Matematik induksiya metodi	88

III BOB. KOMPLEKS SONLAR VA ULAR USTIDA AMALLAR

1- §. Algebraik shakldagi kompleks sonlar va ular ustida amallar	93
2- §. Trigonometrik shakldagi kompleks sonlar va ular ustida amallar	101
1. Kompleks sonning trigonometrik shakli	101
2. Trigonometrik shaklda berilgan kompleks sonlarni ko'paytirish, bo'lish, darajaga ko'tarish	108
3. Kompleks sondan ildiz chiqarish	111

IV BOB. KO'PHADLAR

1- §. Birhadlar va ko'phadlar	121
1. Algebraik ifoda. Natural ko'rsatkichli daraja. Birhad	121
2. Ko'phadlar	125
3. Qisqa ko'paytirish formulalarining umumlashmalari	134
4. Ko'phadlarni bo'lish	137

V BOB. ALGEBRAIK IFODALAR

1- §. Ratsional ifodalar	142
1. Butun ko'rsatkichli daraja	142
2. Ratsional ifodalarni ayniy shakl almashtirish	144
2- §. Irratsional ifodalarni ayniy almashtirishlar	152
1. Arifmetik ildiz. Ratsional ko'rsatkichli daraja	152
2. Ildiz	155
3. Arifmetik ildizlarni shakl almashtirish	159
4. Irratsional ifodalarni soddalashtirish	165

VI BOB. ALGEBRAIK TENGLAMALAR VA TENGSIZLIKLAR

1- §. Bir o'zgaruvchili tenglamalar	171
1. Tenglama. Teng kuchli tenglamalar	171
2. Bir o'zgaruvchili tenglamalarni yechishning ayrim usullari	173
3. Modul qatnashgan tenglamalar	186

4. Muhammad al-Xorazmiy – algebra fanining asoschisi	193
2- §. Yuqori darajali algebraik tenglamalar	195
1. Bezu teoremasi. Gerner sxemasi. Ko'phadning ildizlari	195
2. Algebraik tenglamalarning kompleks ildizlari	201
3. Butun koeffitsiyentli tenglamalarning ratsional ildizlarini topish	203
4. Tenglamalarni taqribiy yechish	207
3- §. Tengsizliklar	212
1. Bir o'zgaruvchili tengsizliklar	212
2. Chiziqli tengsizliklar va kvadrat tengsizliklar	213
3. Ratsional tengsizliklarni oraliqlar usuli yordamida yechish	217
4. Modul belgisi qatnashgan tengsizliklarni yechish	222
5. Ayniyatlar va tengsizliklarni isbotlash	224
4- §. Tenglamalar sistemasi	230
1. Tenglamalar sistemalari va majmualari	230
2. Tenglamalar sistemalarining geometrik ma'nosi	234
3. Tenglamalar sistemasini grafik usulda yechish	237
4. Teng kuchli sistemalar. Ko'paytuvchilarga ajratish usuli	239
5. Tenglamalar sistemasini algebraik qo'shish usuli yordamida yechish	243
6. Noma'lumlarni chiqarish usuli. Gauss usuli	244
7. O'zgaruvchilarni almashtirish usuli	247
8. Determinant haqida tushuncha. Chiziqli tenglamalar sistemasini determinantlar yordamida yechish	254
5- §. Tenglamalar tuzishga doir masalalar	262
6- §. Tengsizliklar sistemasi	271
1. Bir o'zgaruvchili ratsional tengsizliklar sistemasi va majmuasi	271
2. Ikki o'zgaruvchili tengsizliklar	274
7- §. Irratsional tenglamalar va tengsizliklar	278
1. Irratsional tenglamalar	278
2. Irratsional tengsizliklar	284

VII BOB. FUNKSIYALAR

1- §. Sonli funksiyalar	289
1. Funksiya va argument	289
2. Funksiyani bo'laklarga ajratib berish	294
3. Funksiya grafigini nuqtalar bo'yicha yasash	298
4. Funksiyalar ustida amallar	302
2- §. Grafiklarni almashtirish	304
1. Geometrik almashtirishlarda nuqta koordinatalarining o'zgarishi	304
2. Funksiya grafigini almashtirish	307
3. Chiziqli funksiya grafigi	310
4. Kvadrat funksiya grafigi	312
5. Kasr-chiziqli funksiya grafigi	314
6. Ifodasi modul ishorasiga ega bo'lgan funksiyalarning grafigi	316
7. Darajali funksiya grafigi	319
3- §. Funksiyalarni tekshirish	321
1. Juft va toq funksiyalar	321
2. Funksiya qiymatlarining o'zgarishi	324
3. Davriy funksiya	332
4. Teskari funksiya	335
5. Jadval bilan berilgan funksiya ifodasini tuzish	337

VIII BOB. KO'RSATKICHLI VA LOGARIFMIK FUNKSIYALAR

1- §. Ko'rsatkichli funksiya	348
1. Irratsional ko'rsatkichli daraja	348
2. Ko'rsatkichli funksiya va uning xossalari	349
2- §. Logarifmik funksiya	352
1. Logarifmlar. Logarifmik funksiya	352
2. Ko'rsatkichli va logarifmik ifodalarni ayniy almashtirishlar	359
3- §. Ko'rsatkichli va logarifmik tenglamalar, tengsizliklar.....	363
1. Ko'rsatkichli tenglamalar va tengsizliklar	363
2. Logarifmik tenglamalar va tengsizliklar	367
3. Ko'rsatkichli va logarifmik tenglamalar sistemalari	372
Javoblar	380
Adabiyot	395

22.14
A 15

Algebra va matematik analiz asoslari:
Akad. litseylar uchun darslik / **A. U. Abduhamidov,**
H. A. Nasimov, U. M. Nosirov, J. H. Husanov
[**H. A. Nasimovning** umumiy tahriri ostida];
O'zbekiston Respublikasi Oliy va o'rta maxsus ta'lim
vazirligi, O'rta maxsus, kasb-hunar ta'limi markazi. 7-
nashr. — T.: «O'qituvchi» NMIU, 2008. Q.1. — 400 b.

I. Abduhamidov A.U. va boshq.

ББК 22.14я722
22.161я722

ABDUHAMIDOV ABDUHAKIM USMONOVICH,
NASIMOV HUSAN ABDURAHIMOVICH,
NOSIROV UMARQUL MISIROVICH,
HUSANOV JUMANAZAR HUSANOVICH

**ALGEBRA VA MATEMATIK
ANALIZ ASOSLARI**

I qism

Akademik litseylar uchun darslik

7- nashri

«O'qituvchi» nashriyot-matbaa ijodiy uyi
Toshkent—2008

Muharrirlar: *N.G'oiyov, O'.Husanov*
Rasmlar muharriri *M.Kudryashova*
Tex. muharrir: *T.Greshnikova*
Musahhah *M.Ibrohimova*
Kompyuterda sahifalovchi *M. Sagdullayeva*

Original-maketdan bosishga ruxsat etildi 10.04.08. Bichimi 60×90^{1/16}, Kegli 11
shponli. Tayms gam. Ofset bosma usulida bosildi. Shartli b. t. 25,0. Nashr. t. 19,0.
38596 nusxada bosildi. Buyurtma №250.

O'zbekiston Matbuot va axborot agentligining „O'qituvchi“ nashriyot-matbaa ijodiy
uyi. Toshkent—129. Navoiy ko'chasi 30-uy. // Toshkent. Yunusobod dahasi,
Murodov ko'chasi, 1- uy. Shartnoma 09—53—08.

«O'QITUVCHI»

www.oqituvchi.uz
224-04-12

ISBN 978-9943-02-072-6

